



# **SUPER INVERTER SERIES**

## **MULTI TYPE**

### **Service Manual**



# CONTENTS

1. Precaution .....	1
2 Information servicing.....	3
3. General information of Indoor Units.....	7
4. Features .....	8
5. Dimensions.....	17
6. Service Space (unit: mm).....	22
7. Wiring diagram.....	24
8. Indoor units combination .....	33
9. Operation temperature range.....	36
10. Electronic function.....	37
11. General information of Outdoor Units .....	46
12. Features .....	47
13. Dimensions.....	48
14. Refrigeration Cycle Diagram .....	49
15. Sound Levels .....	51
16. Installation Details.....	52
17. Electronic control function.....	60
18. Troubleshooting.....	65



**Caution: Risk of fire/flammable materials**

※The specifications, designs, and information in this book are subject to change without notice for product improvement.

---

---

# 1. Precaution

## 1.1 Safety Precaution

- To prevent injury to the user or other people and property damage, the following instructions must be followed.
- Incorrect operation due to ignoring instruction will cause harm or damage.
- Before service the unit, be sure to read this service manual at first.

## 1.2 Warning

- Appliance shall be stored in a room without continuously operating open flames (for example an operating gas appliance) and ignition sources (for example an operating electric heater).

### ➤ Installation

- Do not install the unit at place where leakage of flammable gas may occur. In case gas leaks and accumulates at surrounding of the unit, it may cause fire.

- Do not use a defective or underrated circuit breaker. Use this appliance on a dedicated circuit.

There is risk of fire or electric shock.

- For electrical work, contact the dealer, seller, a qualified electrician, or an authorized service center.

Do not disassemble or repair the product, there is risk of fire or electric shock.

- Always ground the product.

There is risk of fire or electric shock.

- Install the panel and the cover of control box securely.

There is risk of fire of electric shock.

- Always install a dedicated circuit and breaker.

Improper wiring or installation may cause fore or electric shock.

- Use the correctly rated breaker of fuse.

There is risk of fire or electric shock.

- Do not modify or extend the power cable.

There is risk of fire or electric shock.

- Do not install, remove, or reinstall the unit by yourself (customer).

There is risk of fire, electric shock, explosion, or injury.

- Be caution when unpacking and installing the product.

Sharp edges could cause injury, be especially careful of the case edges and the fins on the condenser and evaporator.

- For installation, always contact the dealer or an authorized service center.

- Do not install the product on a defective installation stand.

- Be sure the installation area does not deteriorate with age.

If the base collapses, the air conditioner could

fall with it, causing property damage, product failure, and personal injury.

- Do not let the air conditioner run for a long time when the humidity is very high and a door or a window is left open.

- Take care to ensure that power cable could not be pulled out or damaged during operation.

There is risk of fire or electric shock.

- Do not place anything on the power cable.

There is risk of fire or electric shock.

- Do not plug or unplug the power supply plug during operation.

There is risk of fire or electric shock.

- Do not touch (operation) the product with wet hands.

- Do not place a heater or other appliance near the power cable.

There is risk of fire and electric shock.

- Do not allow water to run into electrical parts.

It may cause fire, failure of the product, or electric shock.

- Do not store or use flammable gas or combustible near the product.

There is risk of fire or failure of product.

- Do not use the product in a tightly closed space for a long time.

Oxygen deficiency could occur.

- When flammable gas leaks, all naked flames shall be removed or extinguished.

- If strange sounds or smoke comes from product, turn the breaker off or disconnect the power supply cable.

There is risk of electric shock or fire.

- Stop operation and close the window in storm or hurricane. If possible, remove the product from the window before the hurricane arrives.

There is risk of property damage, failure of product, or electric shock.

- Do not open the inlet grill of the product during operation. (Do not touch the electrostatic filter, if the unit is so equipped.)

There is risk of physical injury, electric shock, or product failure.

- When the product is soaked, contact an authorized service center.

There is risk of fire or electric shock.

- Be caution that water could not enter the product.

There is risk of fire, electric shock, or product damage.

- Ventilate the product from time to time when operating it together with a stove etc.

There is risk of fire or electric shock.

- Turn the main power off when cleaning or maintaining the product.

There is risk of electric shock.

- 
- **When the product is not be used for a long time, disconnect the power supply plug or turn off the breaker.**

There is risk of product damage or failure, or unintended operation.

- **Take care to ensure that nobody could step on or fall onto the outdoor unit.**

This could result in personal injury and product damage.

#### ➤ **CAUTION**

- **Always check for gas (refrigerant) leakage after installation or repair of product.**

Low refrigerant levels may cause failure of product.

- **Install the drain hose to ensure that water is drained away properly.**

A bad connection may cause water leakage.

- **Keep level even when installing the product.**

It can avoid vibration of water leakage.

- **Do not install the product where the noise or hot air from the outdoor unit could damage the neighborhoods.**

It may cause a problem for your neighbors.

- **Use two or more people to lift and transport the product.**

- **Do not install the product where it will be exposed to sea wind (salt spray) directly.**

It may cause corrosion on the product.

Corrosion, particularly on the condenser and evaporator fins, could cause product malfunction or inefficient operation.

#### ➤ **Operational**

- **Do not expose the skin directly to cool air for long time. (Do not sit in the draft).**

- **Do not use the product for special purposes, such as preserving foods, works of art etc. It is a consumer air conditioner, not a precision refrigerant system.**

There is risk of damage or loss of property.

- **Do not block the inlet or outlet of air flow.**

- **Use a soft cloth to clean. Do not use harsh detergents, solvents, etc.**

There is risk of fire, electric shock, or damage to the plastic parts of the product.

- **Do not touch the metal parts of the product when removing the air filter. They are very sharp.**

- **Do not step on or put anything on the product. (outdoor units)**

- **Always insert the filter securely. Clean the filter every two weeks or more often if necessary.**

A dirty filter reduces the efficiency of the air conditioner and could cause product malfunction or damage.

- **Do not insert hands or other objects**

through air inlet or outlet while the product is operated.

- **Do not drink the water drained from the product.**

- **Use a firm stool or ladder when cleaning or maintaining the product.**

Be careful and avoid personal injury.

- **Replace the all batteries in the remote control with new ones of the same type. Do not mix old and new batteries or different types of batteries.**

There is risk of fire or explosion.

- **Do not recharge or disassemble the batteries. Do not dispose of batteries in a fire.**

They may burn or explode.

- **If the liquid from the batteries gets onto your skin or clothes, wash it well with clean water. Do not use the remote of the batteries have leaked.**

---

## 2 Information servicing

### 1. Checks to the area

Prior to beginning work on systems containing flammable refrigerants, safety checks are necessary to ensure that the risk of ignition is minimised. For repair to the refrigerating system, the following precautions shall be complied with prior to conducting work on the system.

### 2. Work procedure

Work shall be undertaken under a controlled procedure so as to minimise the risk of a flammable gas or vapour being present while the work is being performed.

### 3. General work area

All maintenance staff and others working in the local area shall be instructed on the nature of work being carried out. Work in confined spaces shall be avoided. The area around the work space shall be sectioned off. Ensure that the conditions within the area have been made safe by control of flammable material.

### 4. Checking for presence of refrigerant

The area shall be checked with an appropriate refrigerant detector prior to and during work, to ensure the technician is aware of potentially flammable atmospheres. Ensure that the leak detection equipment being used is suitable for use with flammable refrigerants, i.e. no sparking, adequately sealed or intrinsically safe.

### 5. Presence of fire extinguisher

If any hot work is to be conducted on the refrigeration equipment or any associated parts, appropriate fire extinguishing equipment shall be available to hand. Have a dry powder or CO2 fire extinguisher adjacent to the charging area.

### 6. No ignition sources

No person carrying out work in relation to a refrigeration system which involves exposing any pipe work that contains or has contained flammable refrigerant shall use any sources of ignition in such a manner that it may lead to the risk of fire or explosion. All possible ignition sources, including cigarette smoking, should be kept sufficiently far away from the site of installation, repairing, removing and disposal, during which flammable refrigerant can possibly be released to the surrounding space. Prior to work taking place, the area around the equipment is to be surveyed to make sure that there are no flammable hazards or ignition risks. NO SMOKING signs shall be displayed.

### 7. Ventilated area

Ensure that the area is in the open or that it is adequately ventilated before breaking into the system or conducting any hot work. A degree of ventilation shall continue during the period that the work is carried out. The ventilation should safely disperse any released refrigerant and preferably expel it externally into the atmosphere.

### 8. Checks to the refrigeration equipment

Where electrical components are being changed, they shall be fit for the purpose and to the correct specification. At all times the manufacturer's maintenance and service guidelines shall be followed. If in doubt consult the manufacturer's technical department for assistance. The following checks shall be applied to installations using flammable refrigerants:

- the charge size is in accordance with the room size within which the refrigerant containing parts are installed;
- the ventilation machinery and outlets are operating adequately and are not obstructed;
- if an indirect refrigerating circuit is being used, the secondary circuit shall be checked for the presence of refrigerant; marking to the equipment continues to be visible and legible.
- markings and signs that are illegible shall be corrected;
- refrigeration pipe or components are installed in a position where they are unlikely to be exposed to any substance which may corrode refrigerant containing components, unless the components are constructed of materials which are inherently resistant to being corroded or are suitably protected against being so corroded.

### 9. Checks to electrical devices

Repair and maintenance to electrical components shall include initial safety checks and component inspection procedures. If a fault exists that could compromise safety, then no electrical supply shall be connected to the circuit until it is satisfactorily dealt with. If the fault cannot be corrected immediately but it is necessary to continue operation, an adequate temporary solution shall be used. This shall be reported to the owner of the equipment so all parties are advised. Initial safety checks shall include:

- that capacitors are discharged: this shall be done in a safe manner to avoid possibility of sparking;

---

- that there no live electrical components and wiring are exposed while charging, recovering or purging the system;

- that there is continuity of earth bonding.

## 10. Repairs to sealed components

10.1 During repairs to sealed components, all electrical supplies shall be disconnected from the equipment being worked upon prior to any removal of sealed covers, etc. If it is absolutely necessary to have an electrical supply to equipment during servicing, then a permanently operating form of leak detection shall be located at the most critical point to warn of a potentially hazardous situation.

10.2 Particular attention shall be paid to the following to ensure that by working on electrical components, the casing is not altered in such a way that the level of protection is affected. This shall include damage to cables, excessive number of connections, terminals not made to original specification, damage to seals, incorrect fitting of glands, etc.

- Ensure that apparatus is mounted securely.
- Ensure that seals or sealing materials have not degraded such that they no longer serve the purpose of preventing the ingress of flammable atmospheres. Replacement parts shall be in accordance with the manufacturer's specifications.

NOTE: The use of silicon sealant may inhibit the effectiveness of some types of leak detection equipment. Intrinsically safe components do not have to be isolated prior to working on them.

## 11. Repair to intrinsically safe components

Do not apply any permanent inductive or capacitance loads to the circuit without ensuring that this will not exceed the permissible voltage and current permitted for the equipment in use. Intrinsically safe components are the only types that can be worked on while live in the presence of a flammable atmosphere. The test apparatus shall be at the correct rating.

Replace components only with parts specified by the manufacturer. Other parts may result in the ignition of refrigerant in the atmosphere from a leak.

## 12. Cabling

Check that cabling will not be subject to wear, corrosion, excessive pressure, vibration, sharp edges or any other adverse environmental effects. The check shall also take into account the effects of aging or continual vibration from sources such as compressors or fans.

## 13. Detection of flammable refrigerants

Under no circumstances shall potential sources of ignition be used in the searching for or detection of

refrigerant leaks. A halide torch (or any other detector using a naked flame)

shall not be used.

## 14. Leak detection methods

The following leak detection methods are deemed acceptable for systems containing flammable refrigerants. Electronic leak detectors shall be used to detect flammable

refrigerants, but the sensitivity may not be adequate, or may need re-calibration. (Detection equipment shall be calibrated in a refrigerant-free area.) Ensure that the detector is not a potential source of ignition and is suitable for the refrigerant used. Leak detection equipment shall be set at a percentage of the LFL of the refrigerant and shall be calibrated to the refrigerant employed and the appropriate percentage of gas (25 % maximum) is confirmed. Leak detection fluids are suitable for use with most refrigerants but the use of detergents containing chlorine shall be avoided as the chlorine may react with the refrigerant and corrode the copper pipe-work.

If a leak is suspected, all naked flames shall be removed or extinguished.

If a leakage of refrigerant is found which requires brazing, all of the refrigerant shall be recovered from the system, or isolated (by means of shut off valves) in a part of the system remote from the leak. Oxygen free nitrogen (OFN) shall then be purged through the system both before and during the brazing process.

## 15. Removal and evacuation

When breaking into the refrigerant circuit to make repairs or for any other purpose conventional procedures shall be used. However, it is important that best practice is followed since flammability is a consideration. The following procedure shall be adhered to:

- remove refrigerant;
- purge the circuit with inert gas;
- evacuate;
- purge again with inert gas;
- open the circuit by cutting or brazing.

The refrigerant charge shall be recovered into the correct recovery cylinders. The system shall be flushed with OFN to render the unit safe. This process may need to be repeated several times. Compressed air or oxygen shall not be used for this task. Flushing shall be achieved by breaking the vacuum in the system with OFN and continuing to fill until the working pressure is achieved, then venting to atmosphere, and finally pulling down to a vacuum. This process shall be repeated until no refrigerant is within the system. When the final OFN charge is used, the system

---

shall be vented down to atmospheric pressure to enable work to take place. This operation is absolutely vital if brazing operations on the pipe-work are to take place.

Ensure that the outlet for the vacuum pump is not close to any ignition sources and there is ventilation available.

### **16. Charging procedures**

In addition to conventional charging procedures, the following requirements shall be followed:

- Ensure that contamination of different refrigerants does not occur when using charging equipment. Hoses or lines shall be as short as possible to minimize the amount of refrigerant contained in them.
- Cylinders shall be kept upright.
- Ensure that the refrigeration system is earthed prior to charging the system with refrigerant.
- Label the system when charging is complete (if not already).
- Extreme care shall be taken not to overfill the refrigeration system.
- Prior to recharging the system it shall be pressure tested with OFN. The system shall be leak tested on completion of charging but prior to commissioning. A follow up leak test shall be carried out prior to leaving the site.

### **17. Decommissioning**

Before carrying out this procedure, it is essential that the technician is completely familiar with the equipment and all its detail. It is recommended good practice that all refrigerants are recovered safely. Prior to the task being carried out, an oil and refrigerant sample shall be taken.

In case analysis is required prior to re-use of reclaimed refrigerant. It is essential that electrical power is available before the task is commenced.

- a) Become familiar with the equipment and its operation.
- b) Isolate system electrically.
- c) Before attempting the procedure ensure that:
  - mechanical handling equipment is available, if required, for handling refrigerant cylinders;
  - all personal protective equipment is available and being used correctly;
  - the recovery process is supervised at all times by a competent person;
  - recovery equipment and cylinders conform to the appropriate standards.
- d) Pump down refrigerant system, if possible.
- e) If a vacuum is not possible, make a manifold so that refrigerant can be removed from various parts of the system.

f) Make sure that cylinder is situated on the scales before recovery takes place.

g) Start the recovery machine and operate in accordance with manufacturer's instructions.

h) Do not overfill cylinders. (No more than 80 % volume liquid charge).

i) Do not exceed the maximum working pressure of the cylinder, even temporarily.

j) When the cylinders have been filled correctly and the process completed, make sure that the cylinders and the equipment are removed from site promptly and all isolation valves on the equipment are closed off.

k) Recovered refrigerant shall not be charged into another refrigeration system unless it has been cleaned and checked.

### **18. Labelling**

Equipment shall be labelled stating that it has been de-commissioned and emptied of refrigerant. The label shall be dated and signed. Ensure that there are labels on the equipment stating the equipment contains flammable refrigerant.



### **19. Recovery**

- When removing refrigerant from a system, either for servicing or decommissioning, it is recommended good practice that all refrigerants are removed safely.
- When transferring refrigerant into cylinders, ensure that only appropriate refrigerant recovery cylinders are employed. Ensure that the correct numbers of cylinders for holding the total system charge are available. All cylinders to be used are designated for the recovered refrigerant and labelled for that refrigerant (i.e. special cylinders for the recovery of refrigerant). Cylinders shall be complete with pressure relief valve and associated shut-off valves in good working order.
- Empty recovery cylinders are evacuated and, if possible, cooled before recovery occurs.
- The recovery equipment shall be in good working order with a set of instructions concerning the equipment that is at hand and shall be suitable for the recovery of flammable refrigerants. In addition, a set of calibrated weighing scales shall be available and in good working order.
- Hoses shall be complete with leak-free disconnect couplings and in good condition. Before using the recovery machine, check that it is in satisfactory working order, has been properly maintained and that any associated electrical components are sealed to prevent ignition in the event of a refrigerant release. Consult manufacturer if in doubt.

- 
- The recovered refrigerant shall be returned to the refrigerant supplier in the correct recovery cylinder, and the relevant Waste Transfer Note arranged. Do not mix refrigerants in recovery units and especially not in cylinders.
  - If compressors or compressor oils are to be removed, ensure that they have been evacuated to an acceptable level to make certain that flammable refrigerant does not remain within the lubricant. The evacuation process shall be carried out prior to returning the compressor to the suppliers. Only electric heating to the compressor body shall be employed to accelerate this process. When oil is drained from a system, it shall be carried out safely.



### 3. General information of Indoor Units

<p>Four-way cassette (compact)</p> 	<p>A6 Ducted</p> 
<p>Console</p> 	<p>Under Ceiling</p> 
<p>15C</p> 	<p>AB</p> 
<p>ODU</p> <div style="display: flex; justify-content: space-around; align-items: flex-start;"> <div style="text-align: center;">  <p>38QUS014D8S2* 38QUS018D8S2* 38QUS021D8S3* 38QUS027D8S3*</p> </div> <div style="text-align: center;">  <p>38QUS028D8S4* 38QUS036D8S4* 38QUS042D8S5*</p> </div> </div>	

Model					
Cassette	Console & Ceiling	15C	AB	A6 Ducted	ODU
42QTD007D8S*	/	42QHC007D8S*	/	42QSS007D8S*	38QUS014D8S2*
42QTD009D8S*	/	42QHC009D8S*	/	42QSS009D8S*	38QUS018D8S2*
42QTD012D8S*	42QZA012D8S*	42QHC012D8S*	42QHB12E8S	42QSS012D8S*	38QUS021D8S3*
42QTD018D8S*	42QZL018D8S*	42QHC018D8S*	42QHB18D8S	42QSS018D8S*	38QUS027D8S3*
/	/	42QHC024D8S*	42QHB24D8S	/	38QUS028D8S4*
/	/	/	/	/	38QUS036D8S4*
/	/	/	/	/	38QUS042D8S5*

---

## 4. Features

### 4.1 Four-way cassette type(compact)

#### (1) New panel

- 360°surrounding air outlet design, affords comfortable feeling

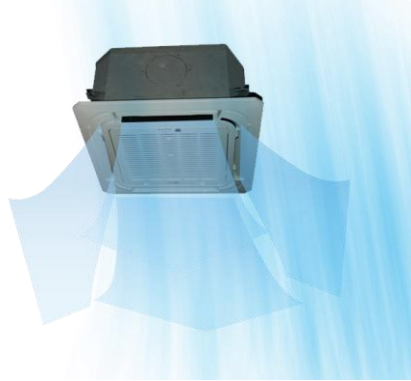

#### (2) Compact design

- The body size is 570×260×570mm, it's just smaller than the ceiling board, so it's very easy for installation and will not damage the decoration. The panel size is 647×50×647mm.
- The hooks are designed in the four corners of the body, which can save installation space.



#### (3) Electric control box built-in design

- The E-box is simply and safely built inside the indoor unit. It's convenient for installation and maintenance. Can check the control part easily, you only need to open the air return grille.



#### (4) Fresh air intake function:

- Fresh air fulfills air quality more healthy and comfortable.

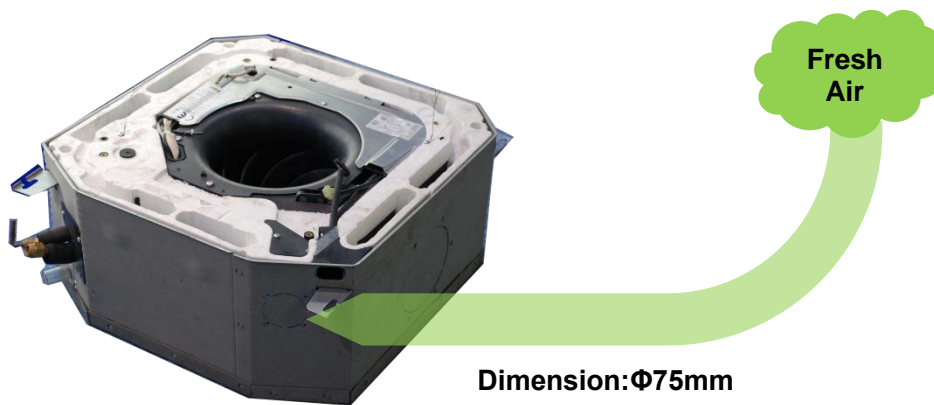

#### (5) Air passage function

- Reserves the space for air outlet from the side of indoor unit; It's availed to connect air duct from the two sides to the nearby small rooms.



## 4.2 Ducted

### 4.2.1 Higher Static Pressure

- As a ducted air conditioner with medium static pressure, it has the widest static pressure range.
- The maximum static pressure reaches 160 Pa

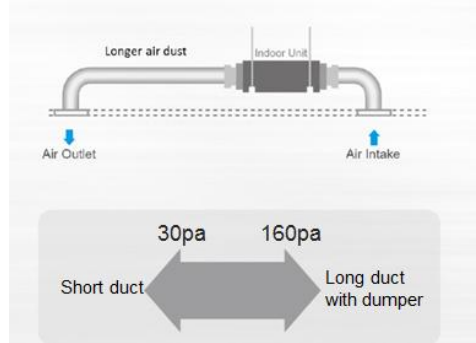

### 4.2.2 Slim Design

- The industry Lowest height is designed to be fitted into tight roof spaces.

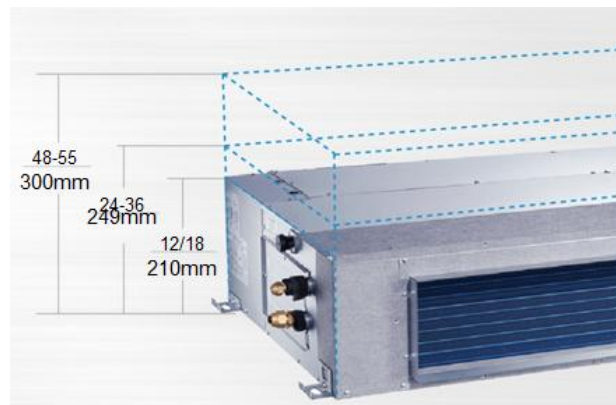

### 4.2.3 Constant air volume control

- For ordinary duct, when the static pressure exceeds the expected range, it is fairly difficult even for an experienced installer to calculate and adjust the air volume precisely.
- With constant air volume control technology, the duct will automatically adjust to perfect static pressure and keep constant air volume.

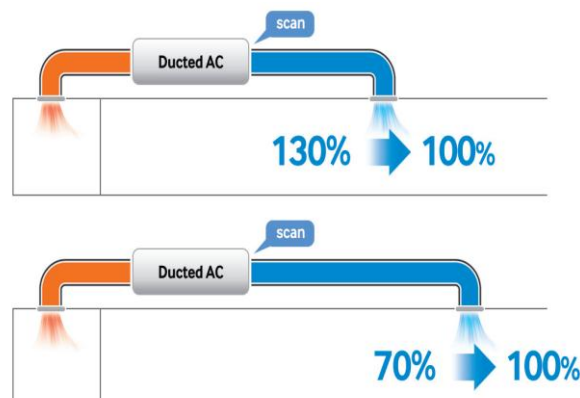

### 4.2.4 Installation accessories: (Optional)

- Canvas Air Passage, Filter, for easy installation

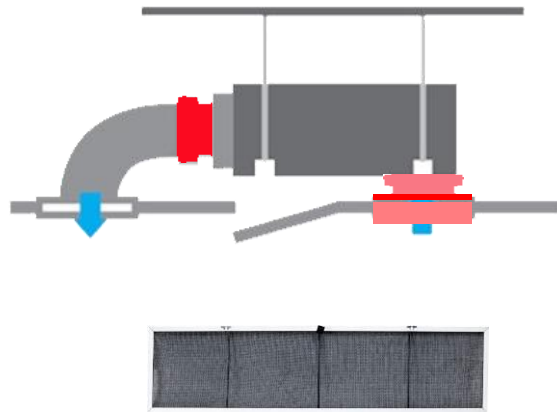

Filter

#### 4.2.5 Flexible Air Intake Way (Bottom side or Rear side)

- The frame size of air inlet in rear and bottom is the same. It's very easy to switch to match different application.

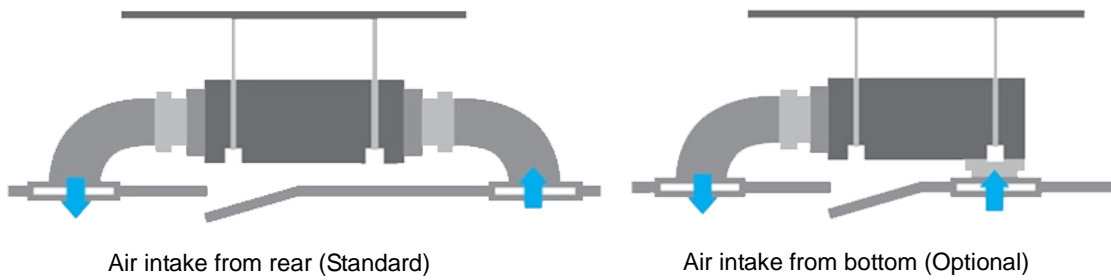

#### 4.2.6 Communication wire connection

- A6 duct uses two wires without polarity connection way, which almost has no mistake during the installation.



#### 4.2.7 Easy Clean

- Clean the filter (Optional, standard product without filter)
- It is easy to draw out the filter from the indoor unit for cleaning, even the filter is installed in rear side or bottom side.

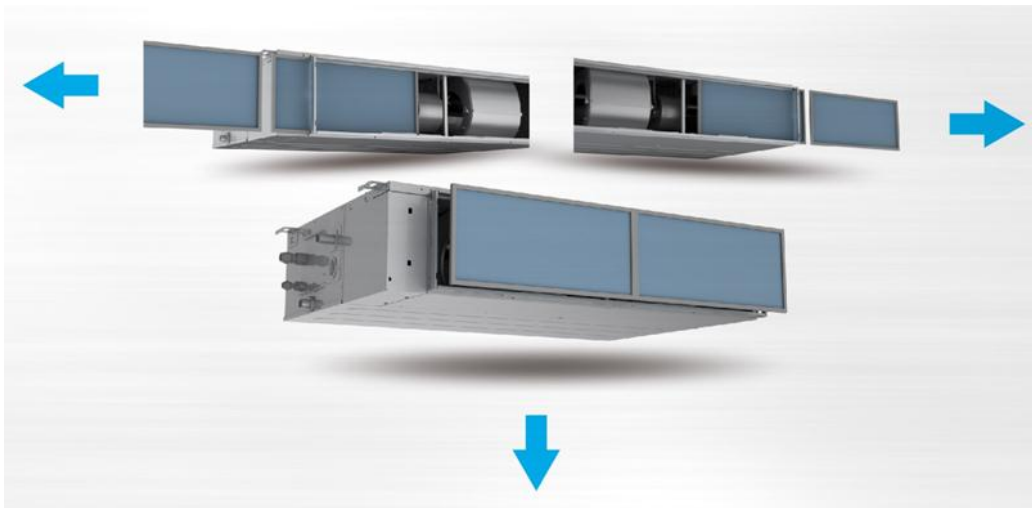

- With a larger window design, once the motor and the blower wheels have been detached, heat exchanger and water receiver tray in behind can be seen very clearly. Dusted can be easily removed from the inside by vacuum



#### 4.2.8 Easy maintenance

- A6 ducted allows operators maintenance the motor from the bottom more easily compare with that on the top.

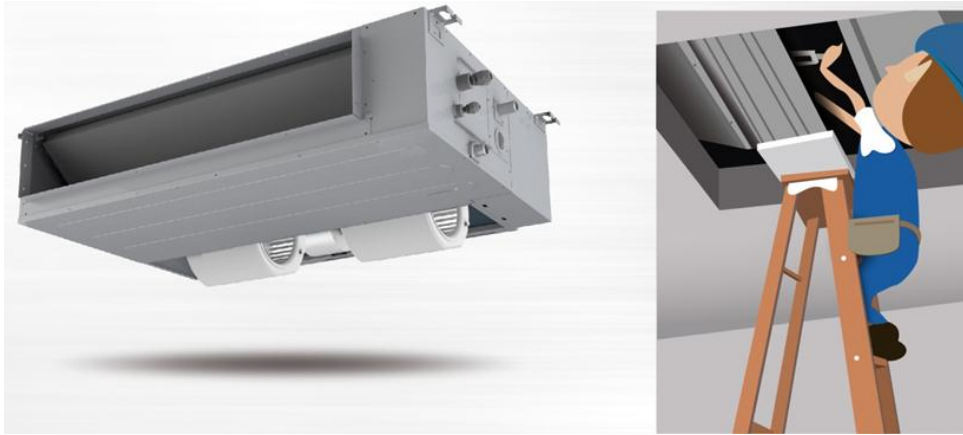

- A6 ducted has big space for maintenance at the side



#### 4.2.9 Fresh air intake function(Optional)

- Install one duct from the reserved fresh-air intake to outdoor.  
Continually inhale the fresh air to improve the quality of the indoor air, fulfills air quality more healthy and comfortable.
- A ventilation motor (provided by the installer) can be installed inside the fresh air duct to improve the fresh air volume. There are reserved ports for this motor on main PCB (Standard for 3D inverter units, and only optional for DC inverter 53~160 units).

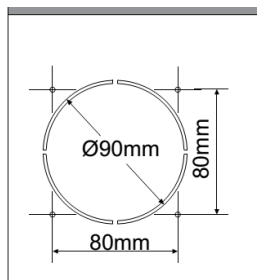

#### 4.2.10 Built-in drain pump (Optional)

- Built-in drain pump can lift the water to 750mm upmost, which widens the drainage piping range.

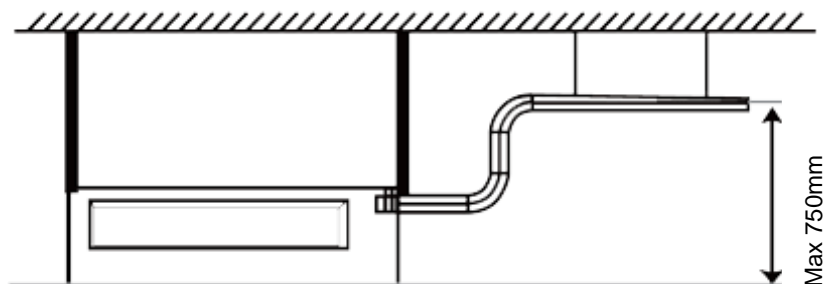

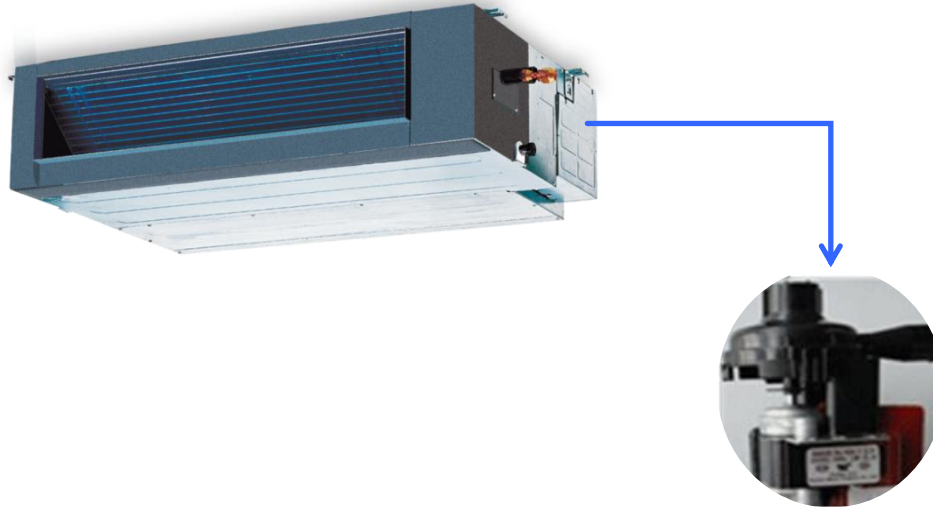

### 4.3 Console

#### 4.3.1 Consumes up to 30% less energy than non-inverter units

- DC inverter compressor
- indoor fan motor adopts DC motor

#### 4.3.2 Achieves set temperature more quickly

- air supplying from top and bottom or from top only
- air inlet from four directions



#### 4.3.3 Compact unit body, space saving

- this unit body is very thin and harmonious with room. It is beautiful, elegant and space saving.
- light weight and compact.

#### 4.3.4 Flexible installation.

- can be used for floor standing or lower wall applications
- as a floor standing floor model, it can be semi or fully recessed without loss of capacity.

#### 4.3.5 High efficiency filter

- built in Formaldehyde nemesis filter
- active-carbon and biological anti-virus filter is optional.

#### 4.3.6 Comfort

- flexible air blow: vertical auto swing and wide angle louvers ensure that warm air reaches the furthest corners of the room and increase the air flow coverage



- 
- Low noise operation, lowest to 23Db
  - Low starting power and precise room temperature adjustment

**4.3.7 Powerful mode can be selected for rapid cooling or heating.**

**4.3.8 Easy cleaning grille and maintenance**

**4.3.9 Indoor unit adopts DC motor, it has five level fan speed meet different requirements.**

## **4.4 Under Ceiling**

**4.4.1 New design, more modern and elegant appearance.**



**4.4.2 Convenient installation**

- The ceiling type can be easily installed into a corner of the ceiling even if the ceiling is very narrow
- It is especially useful when installation of an air conditioner in the center of the ceiling is impossible due to a structure such as one lighting.

**4.4.3 Two direction auto swing (vertical & horizontal) and wide angle air flow,**

- Air flow directional control minimizes the air resistance and produces wider air flow to vertical direction.
- The range of horizontal air discharge is widened which secures wider air flow distribution to provide more comfortable air circulation no matter where the unit is set up

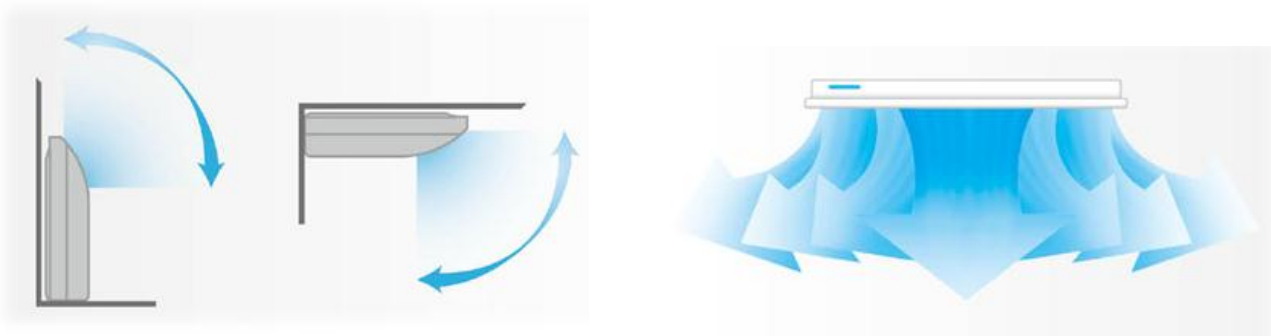

**4.4.4 Three level fan speed, more humanism design, meets different air-supply requirement.**

**1.2.5 New foam drain pan with plastic-spraying inner surface**

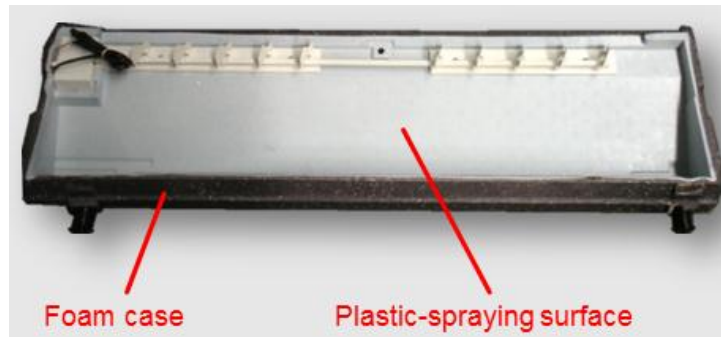

**4.4.6 Easy operation.**

**4.4.7 Remote control and optional wired control method.**

# 5. Dimensions

## 5.1 Four-way cassette type (compact):

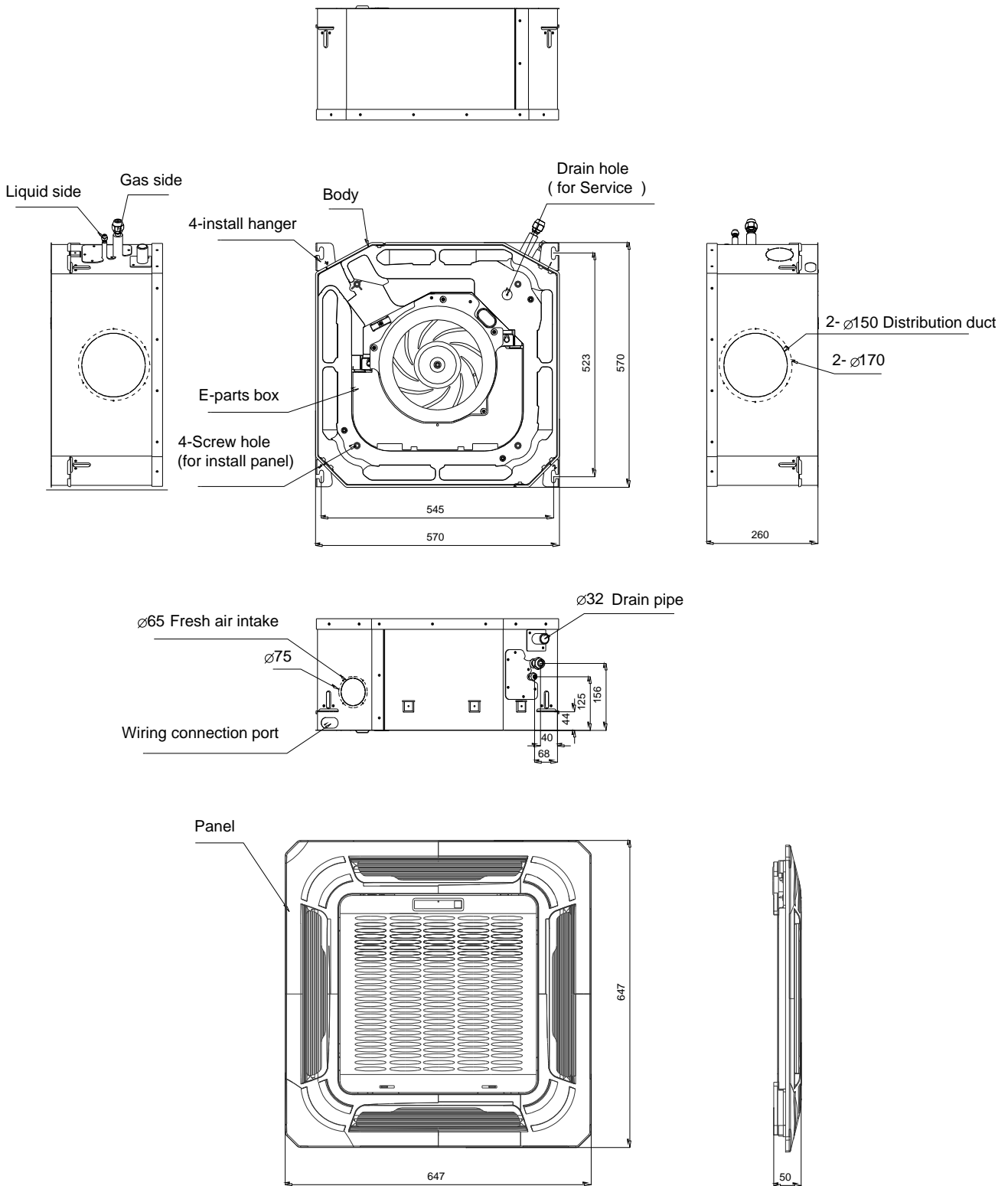

## 5.2 A6 Ducted

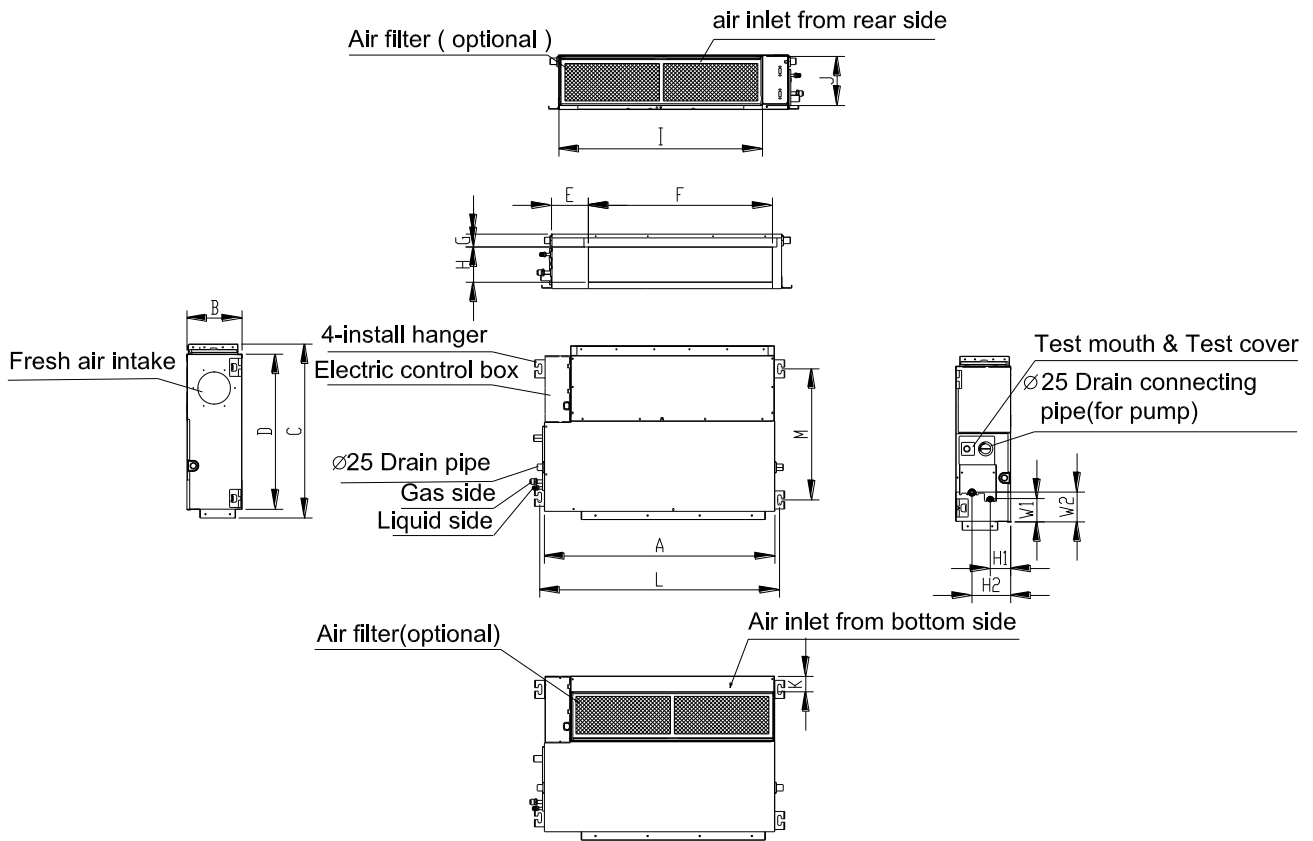

Model (KBtu/h)	unit	A	B	C	D	E	F	G	H	I	J	K	L	M	H1	H2	W1	W2
7/9/12	mm	700	200	506	450	137	537	30	152	599	186	50	741	360	84	140	84	84
	inch	27.6	7.9	19.9	17.7	5.4	21.1	1.2	6.0	23.6	7.3	2.0	29.2	14.2	3.3	5.5	3.3	3.3
18	mm	880	210	674	600	140	706	50	136	782	190	40	920	508	78	148	88	112
	inch	34.65	8.27	26.54	23.62	5.51	27.80	1.97	5.35	30.79	7.48	1.57	36.22	20.00	3.07	5.83	3.46	4.41

### 5.3 Console

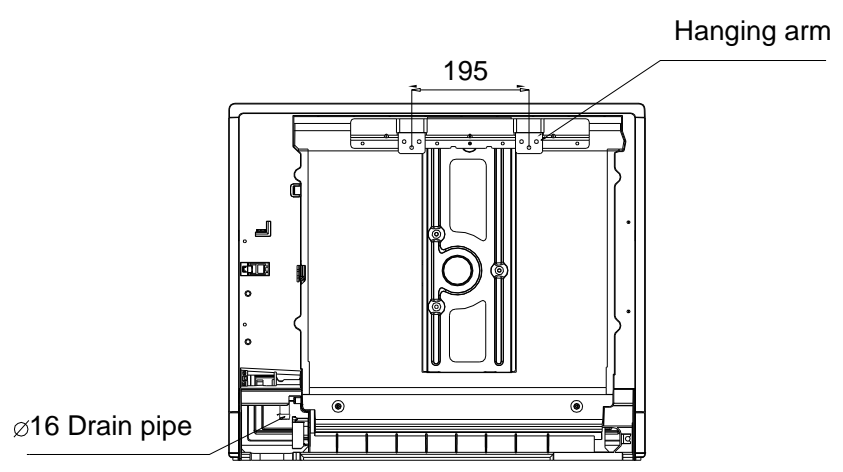
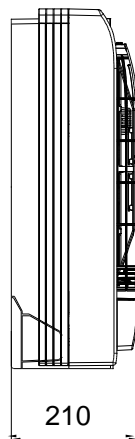
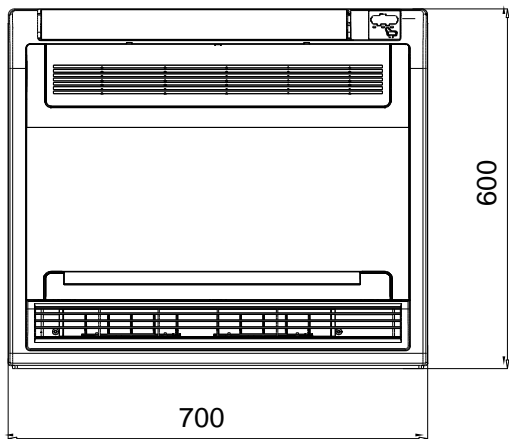
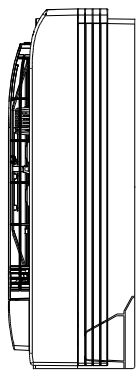
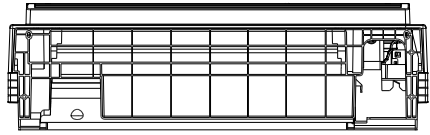

## 5.4 Under Ceiling

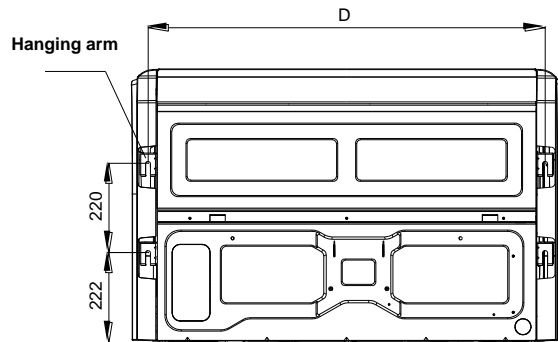
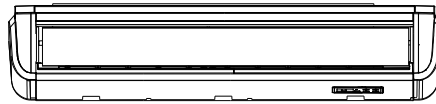
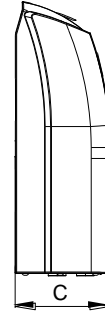
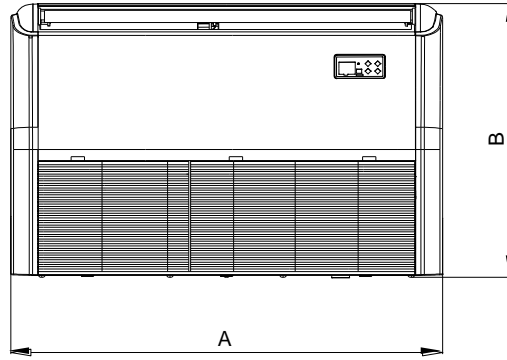
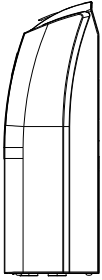
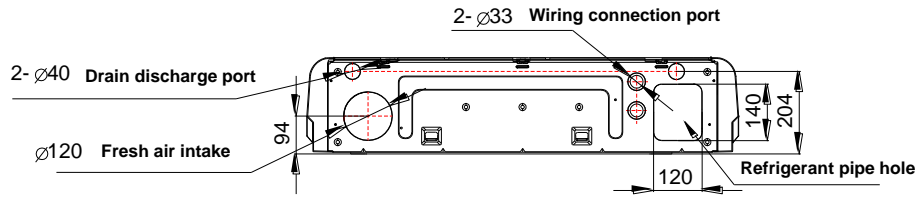

Capacity (KBtu/h)	A	B	C	D
18	1068	675	235	983

## 5.5 Hi-wall

### 5.5.1 15C Indoor Unit

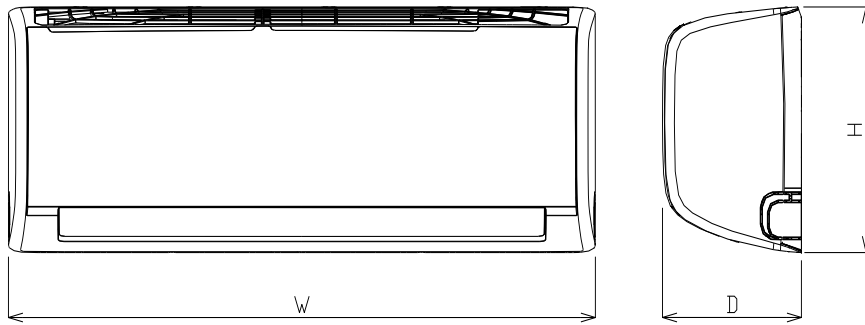

Model (KBtu/h)	W	D	H
7/9	730	192	291
12	812	192	300
18	973	218	319
24	1082	225	338

### 5.5.2 AB Indoor unit

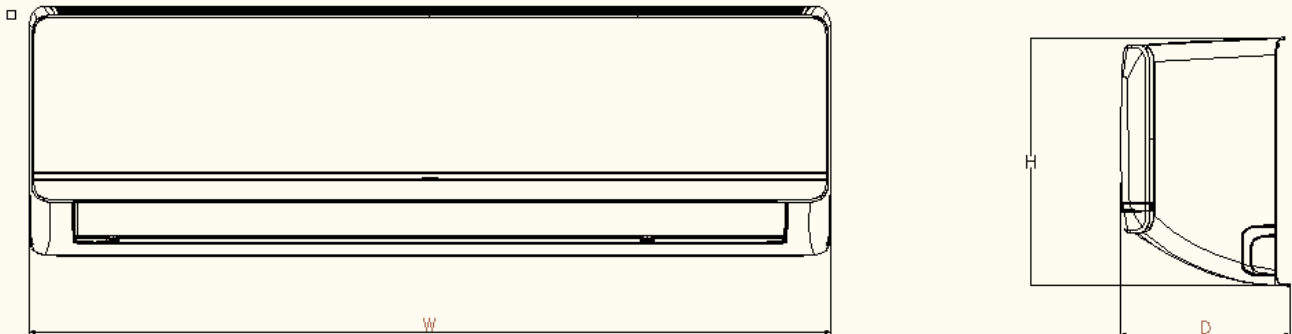

Model (KBtu/h)	W	D	H
12	802	189	297
18	965	215	319
24	1080	226	335

## 6. Service Space (unit: mm)

### 6.1 Four-way cassette (compact)

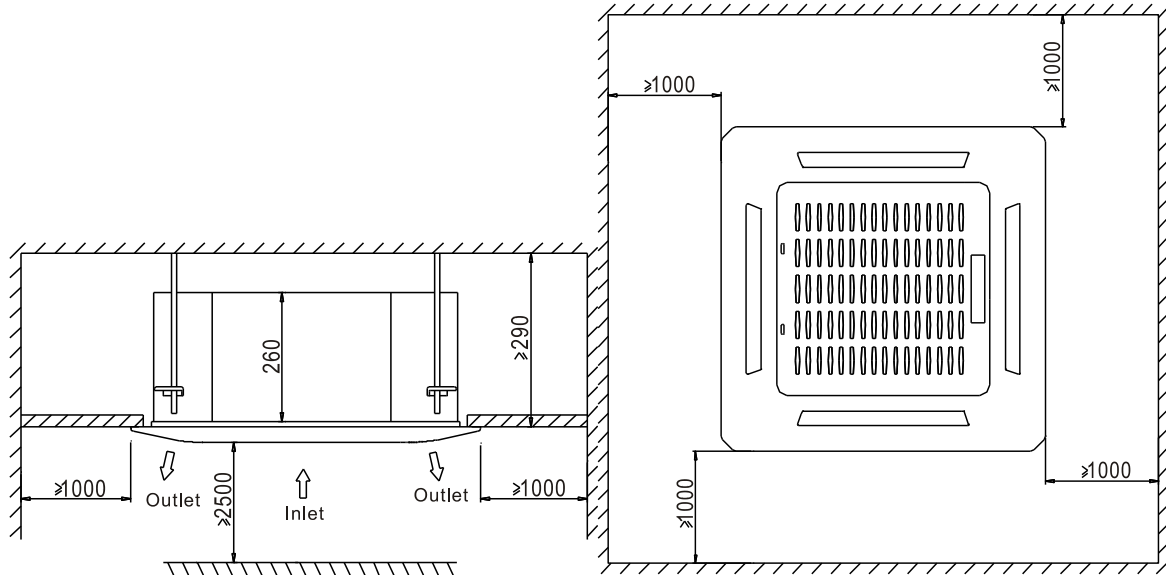

### 6.2 Ducted

Ensure enough space required for installation and maintenance.

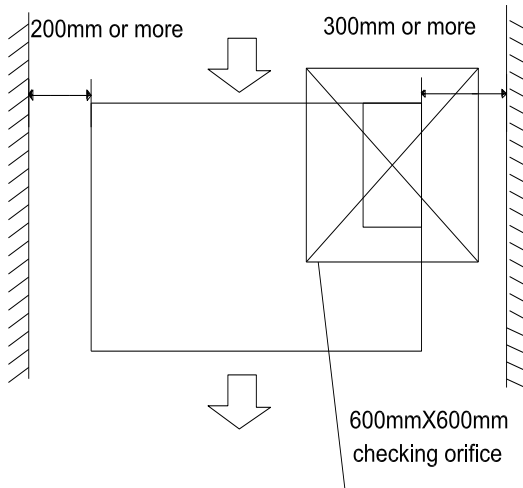

All the indoor units reserve the hole to joint the fresh air pipe. The hole size as following:

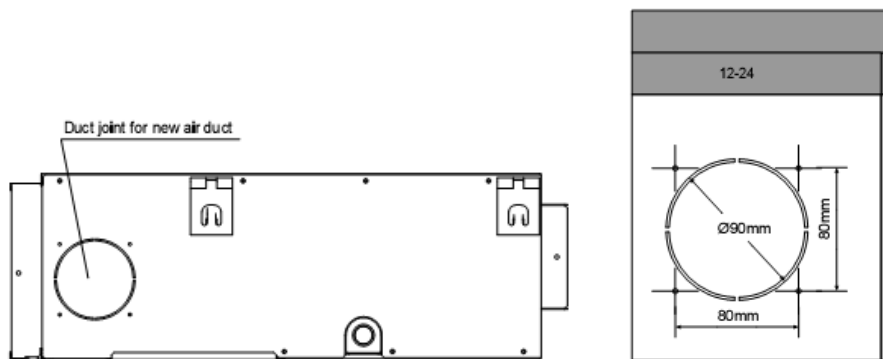



### 6.3 Console

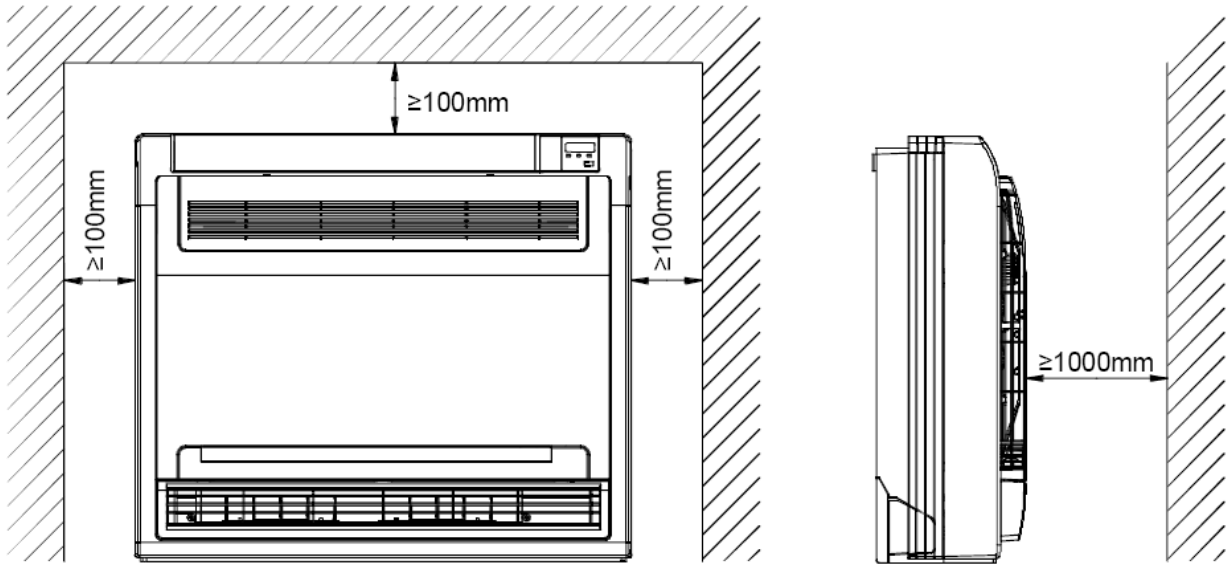

### 6.4 Under Ceiling

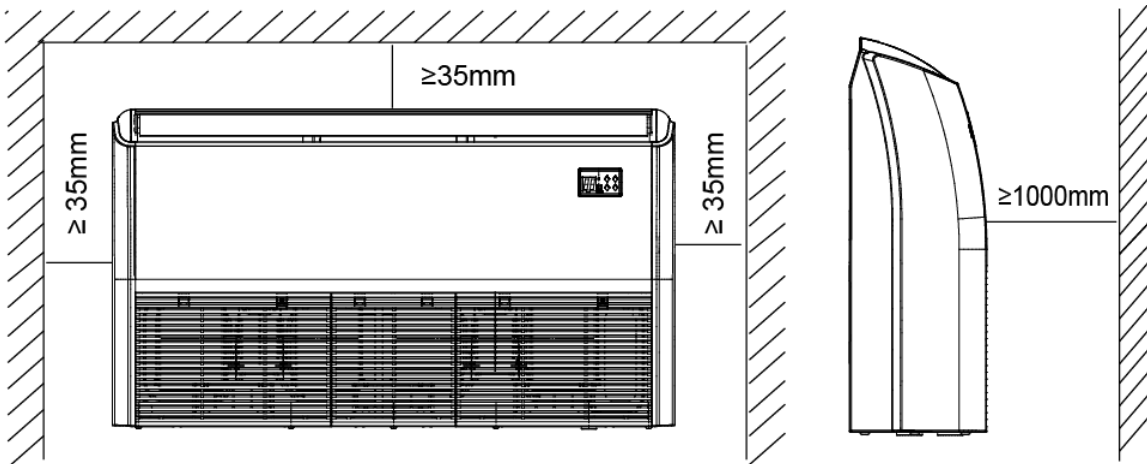

### 6.5 Hi-wall

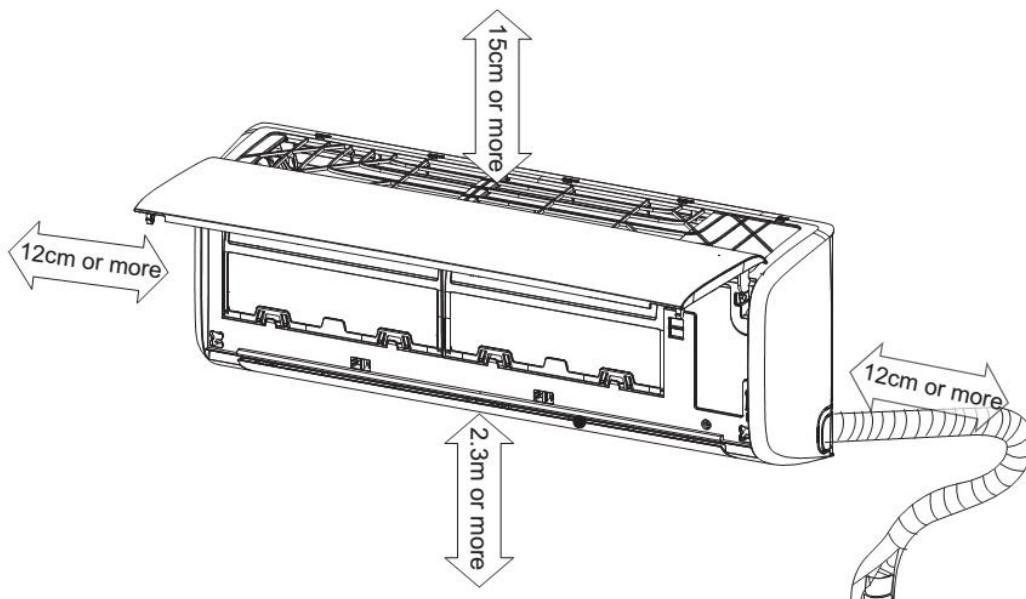

# 7. Wiring diagram

## 38QUS014D8S2\*

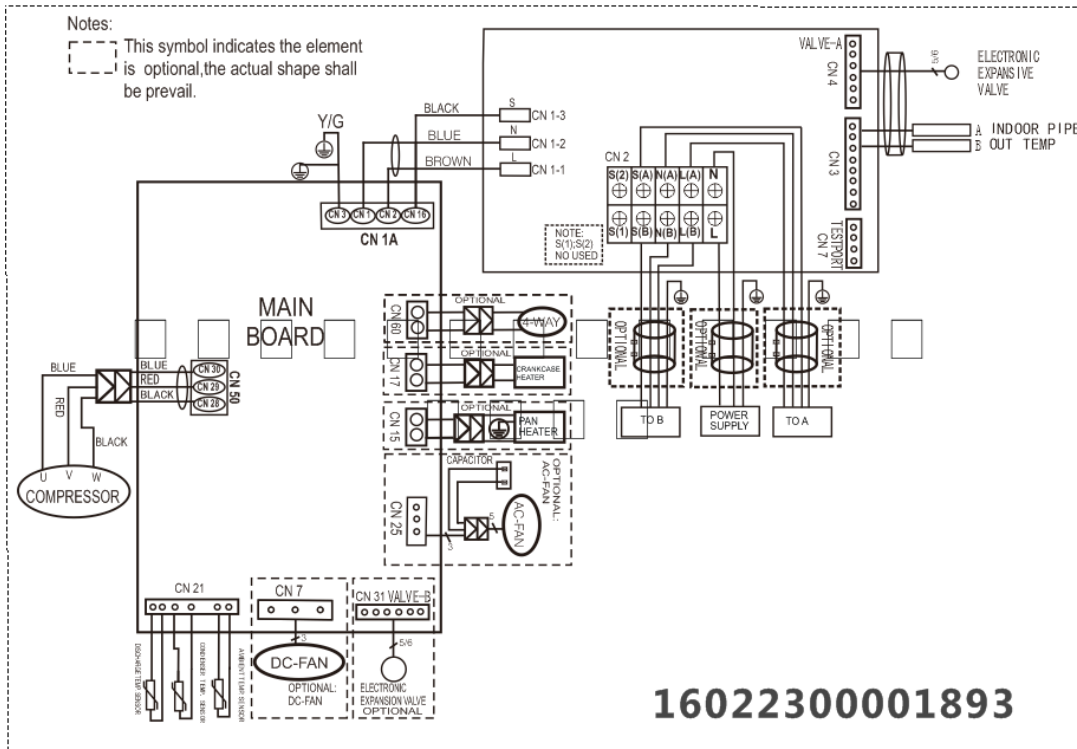

## 38QUS018D8S2\*

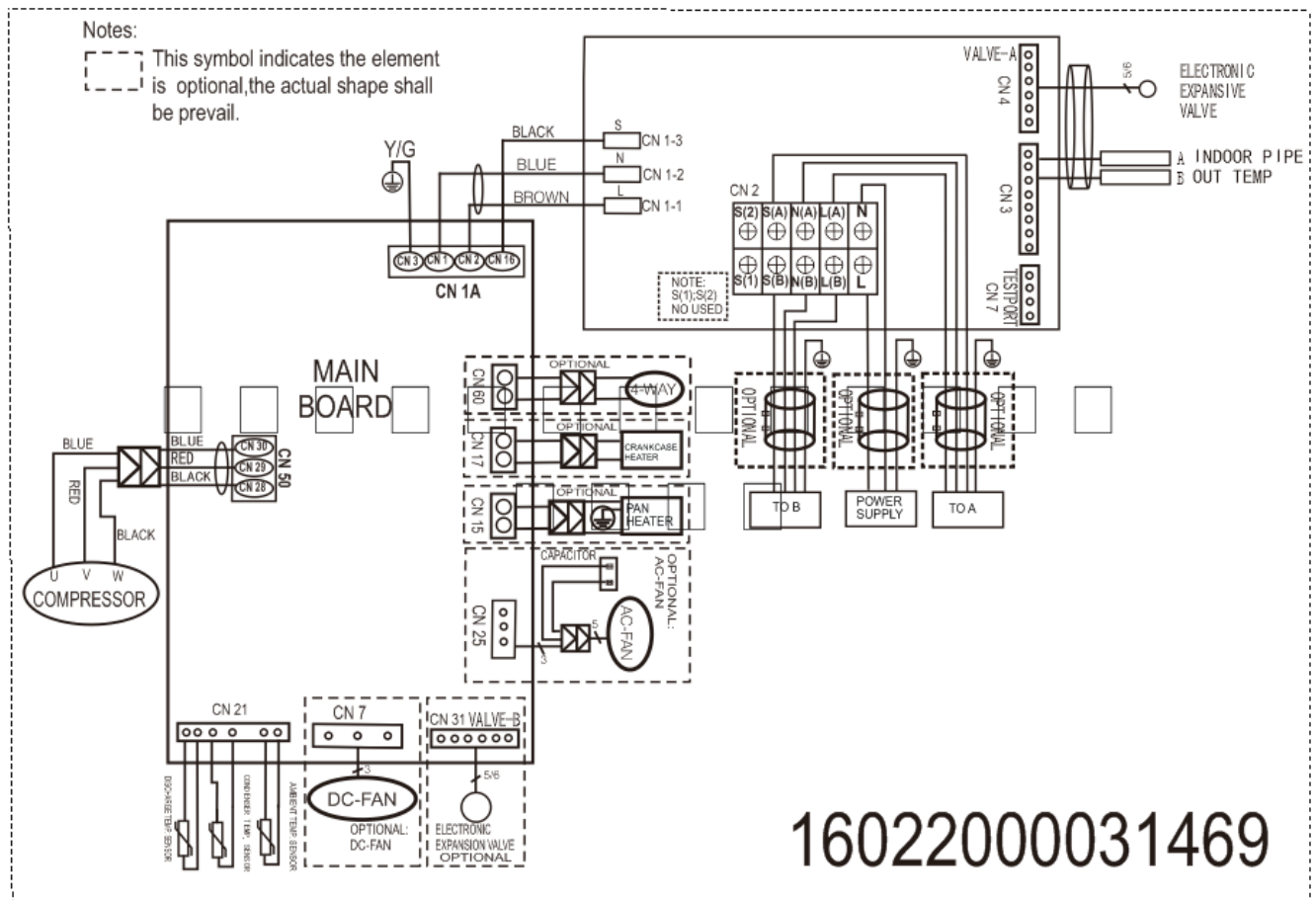

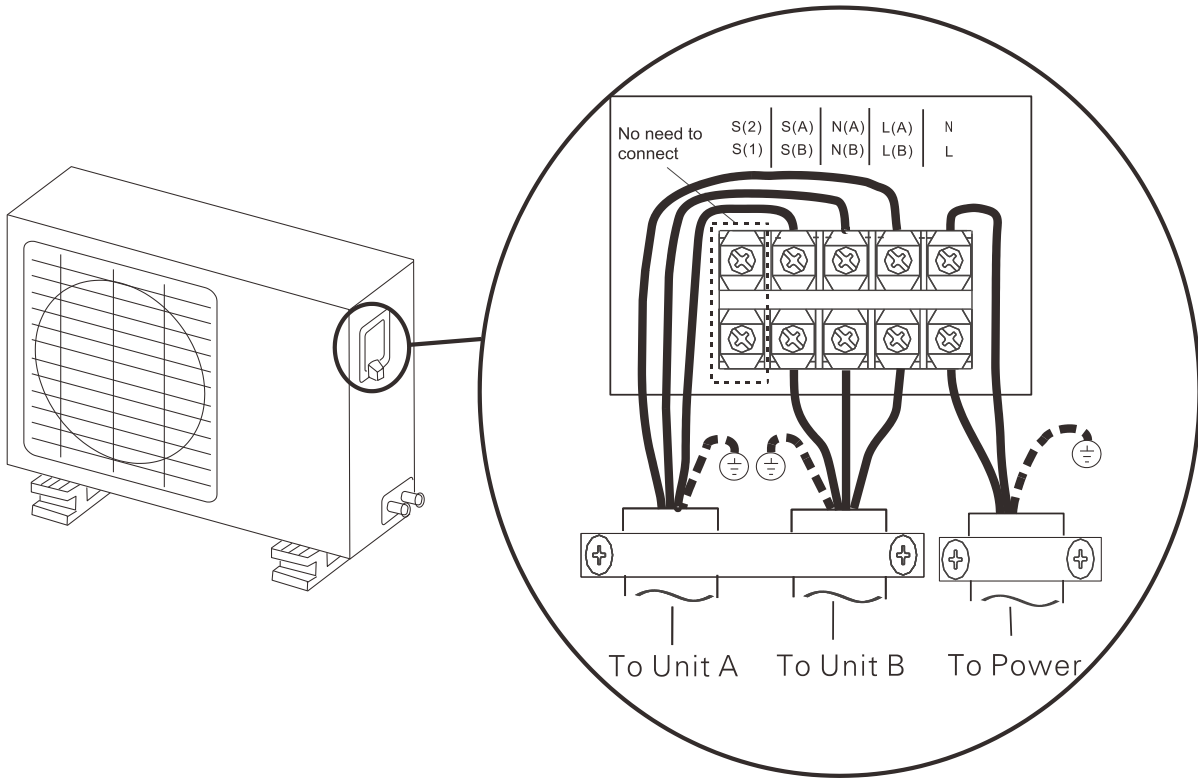

Note: S(1)&S(2) are used in other type of models. They don't need to be connected in multi models.

### 38QUS021D8S3\* & 38QUS027D8S3\*

16022300001873

Notes: - - - - -

- - - - - This symbol indicates the element is optional,
- - - - - the actual shape shall be prevail.
- - - - - This symbol indicates field wiring.

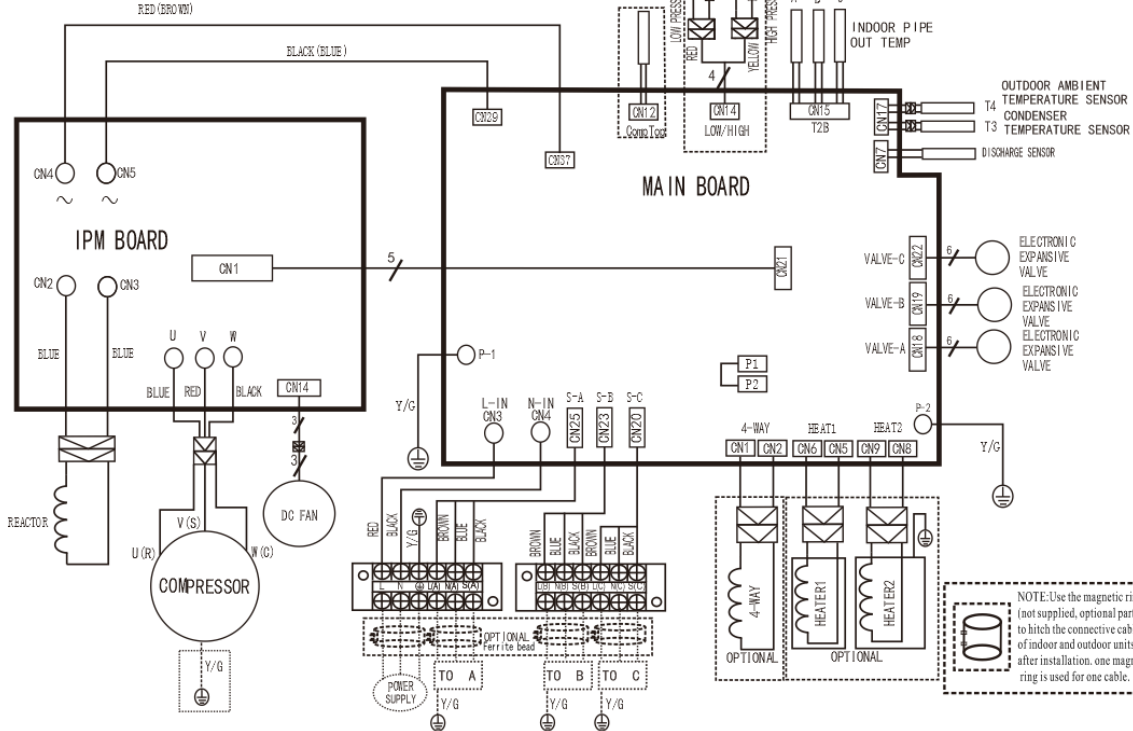

### 38QUS028D8S4\*

16022300001874

Notes: - - - - -

- - - - - This symbol indicates the element is optional,
- - - - - the actual shape shall be prevail.
- - - - - This symbol indicates field wiring.

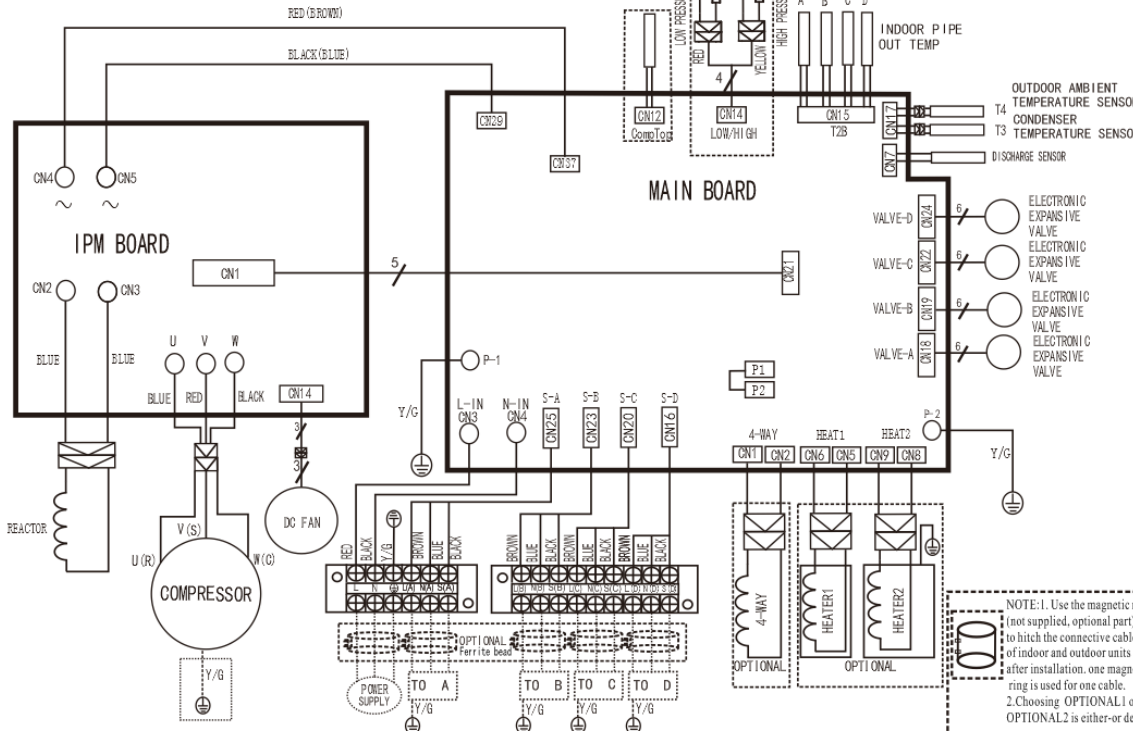

### 38QUS036D8S4\*

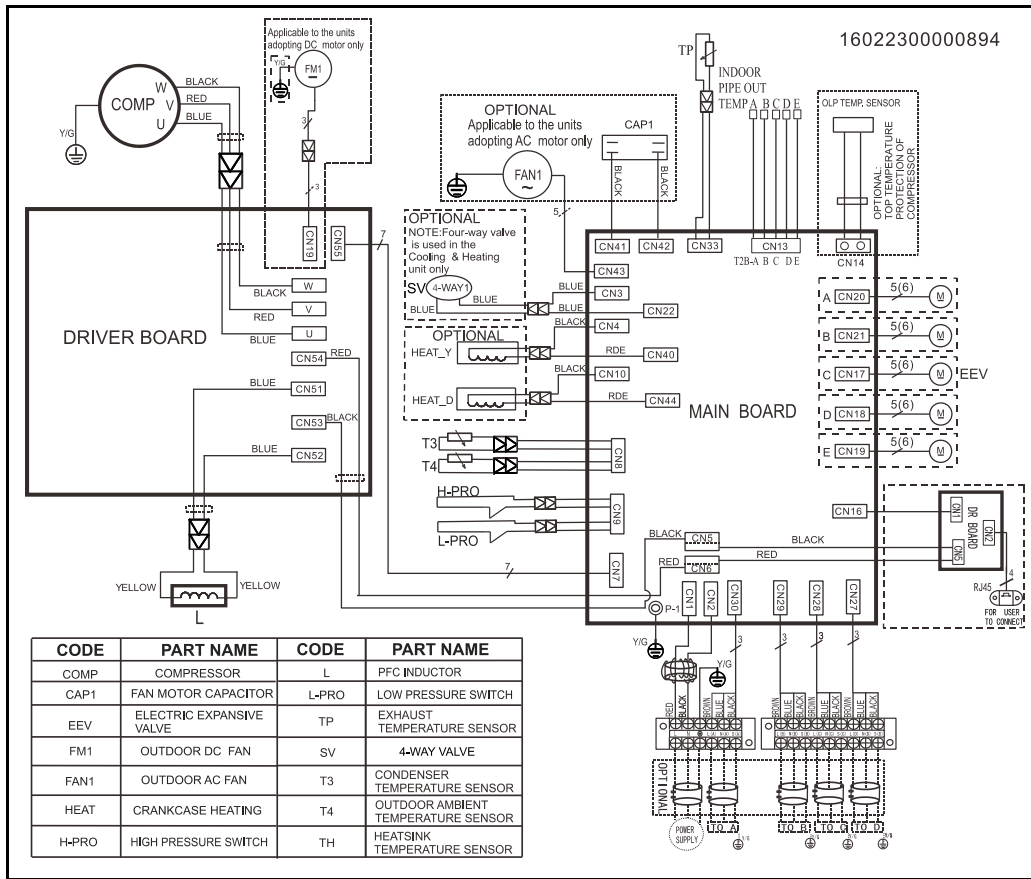

### 38QUS042D8S5\*

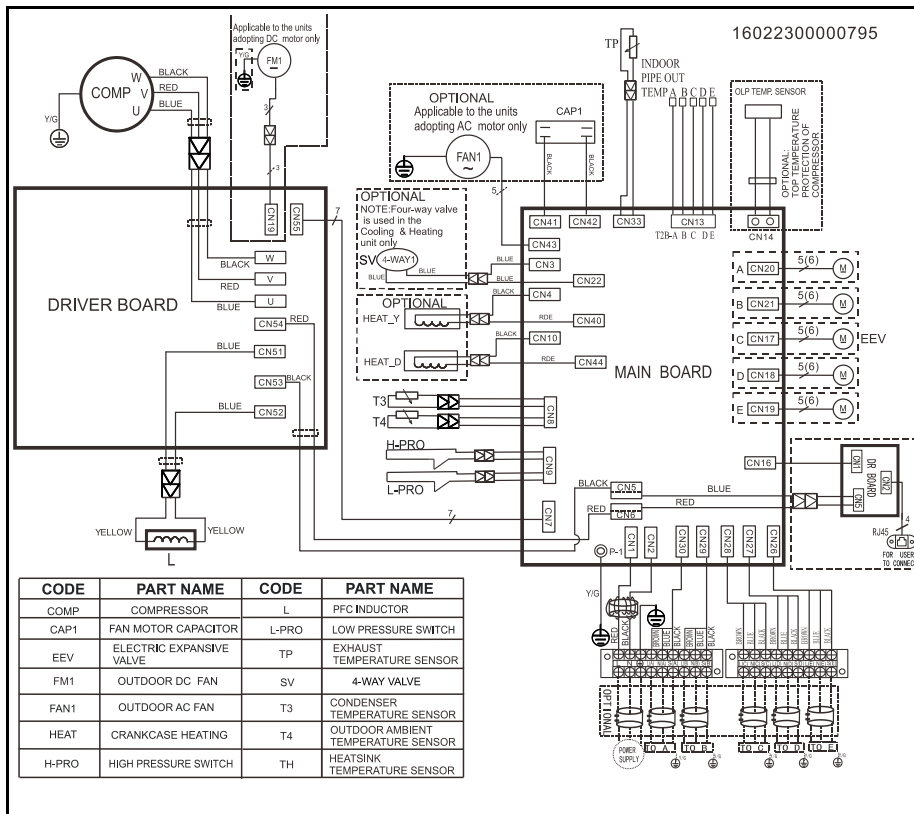

42QHC007D8S\*、42QHC009D8S\*、42QHC012D8S\*、42QHC018D8S\*、42QHC024D8S\*、42QHB12E8S、42QHB18D8S、42QHB24D8S\*

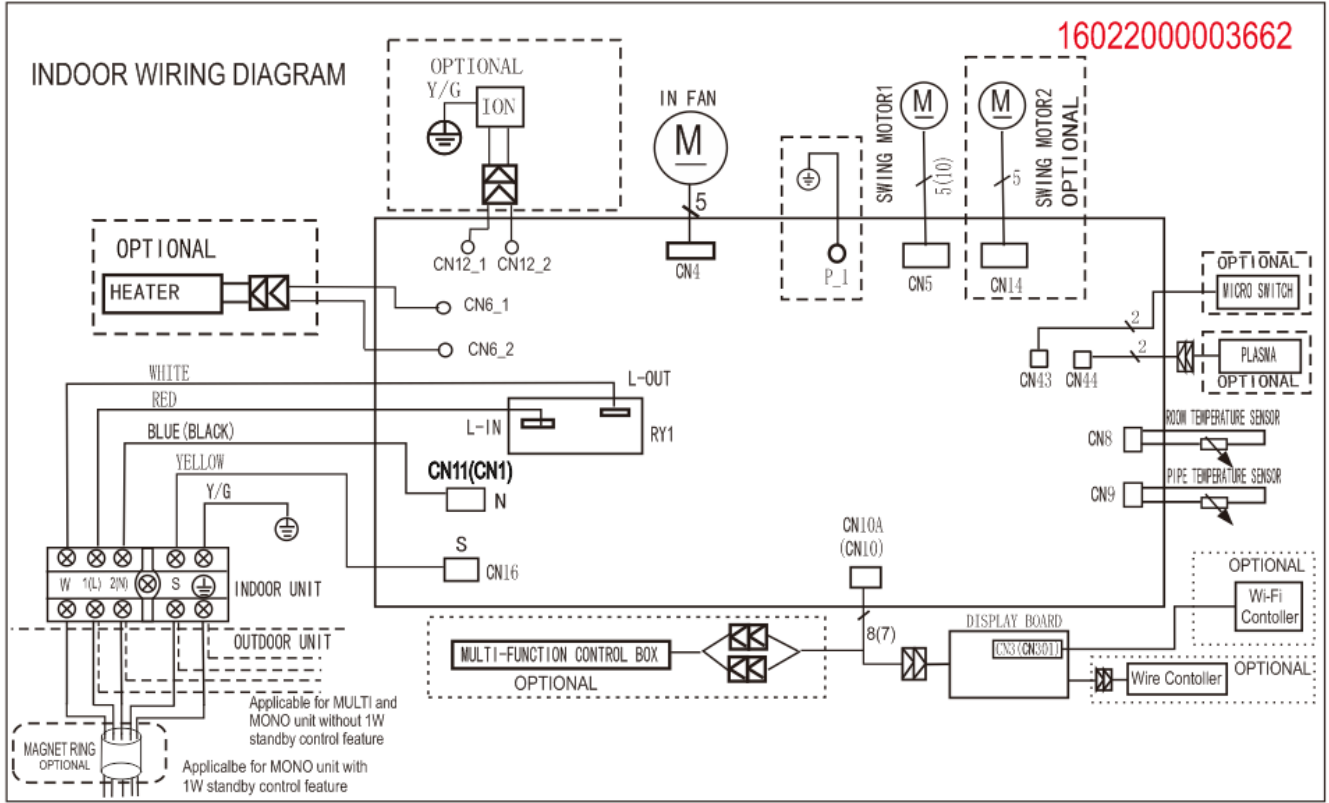

42QTD007D8S\*、42QTD009D8S\*

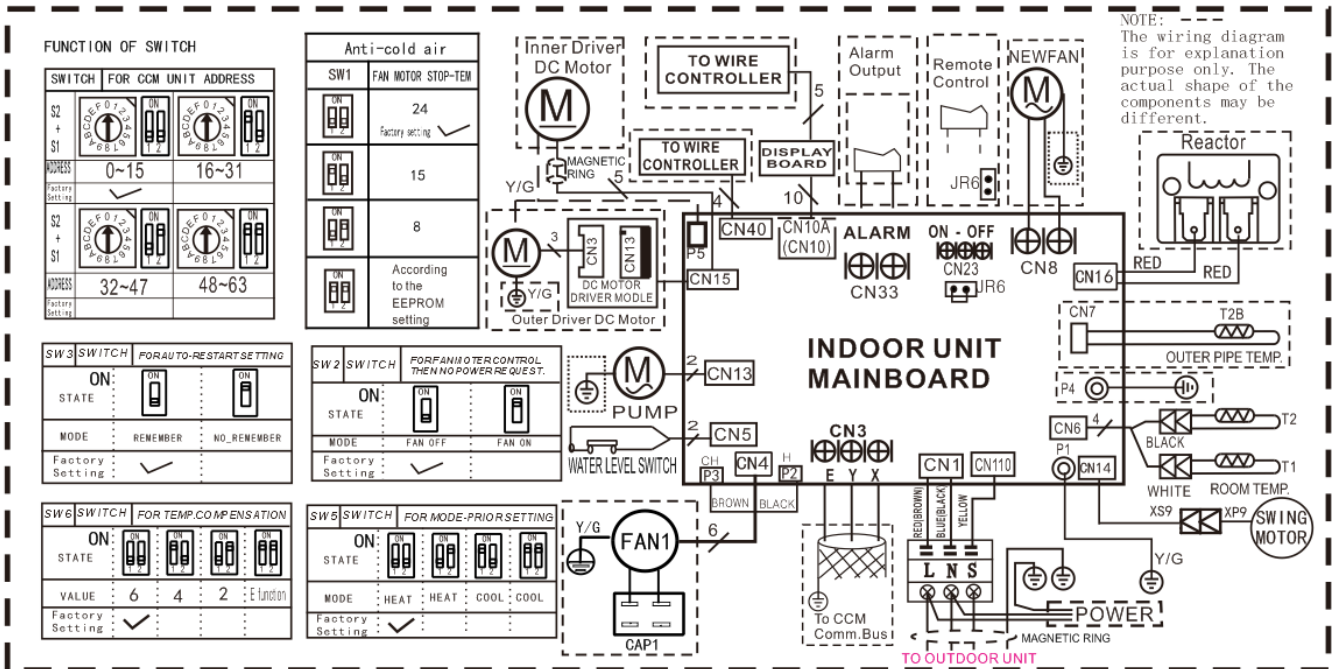

1602250000835

## 42QTD012D8S\*

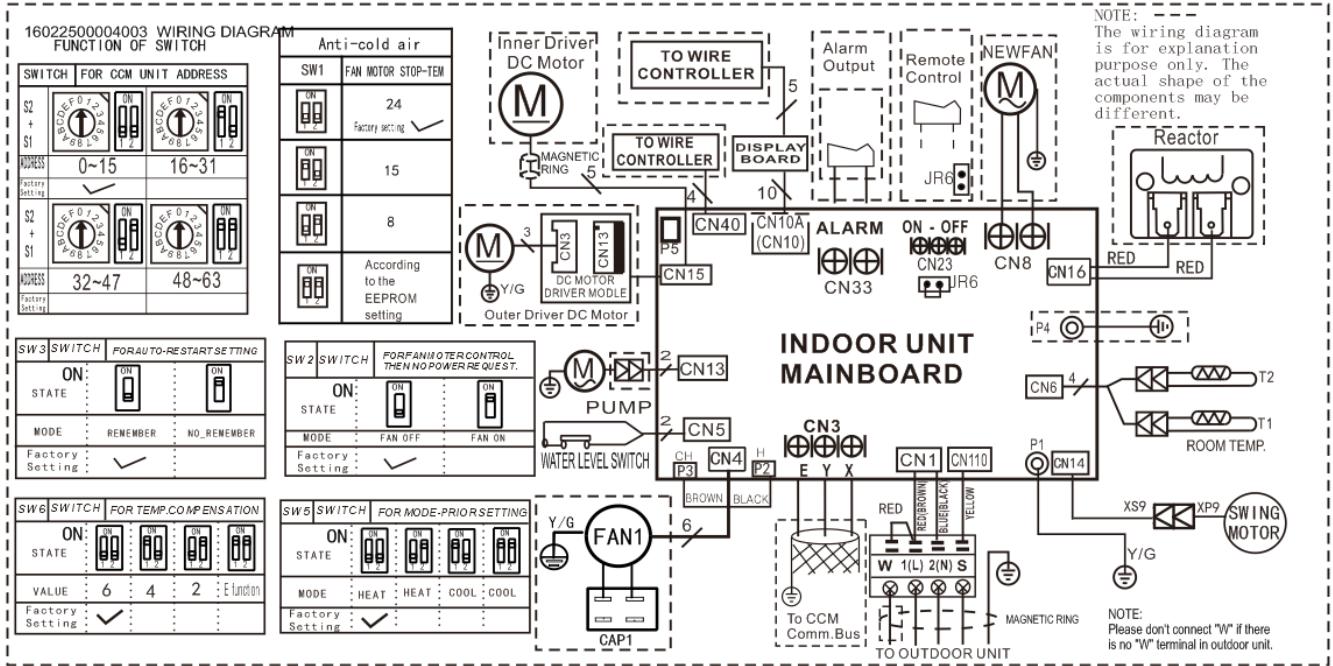

## 42QTD018D8S\*

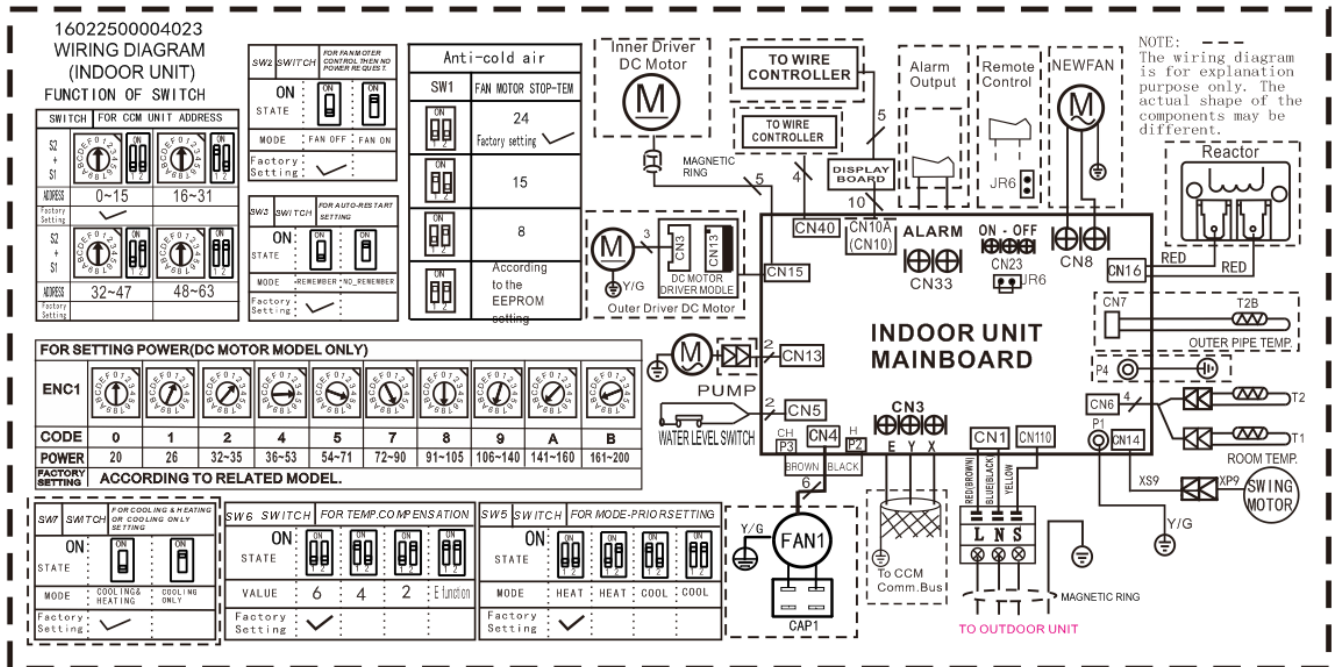

42QSS007D8S\*、42QSS009D8S\*

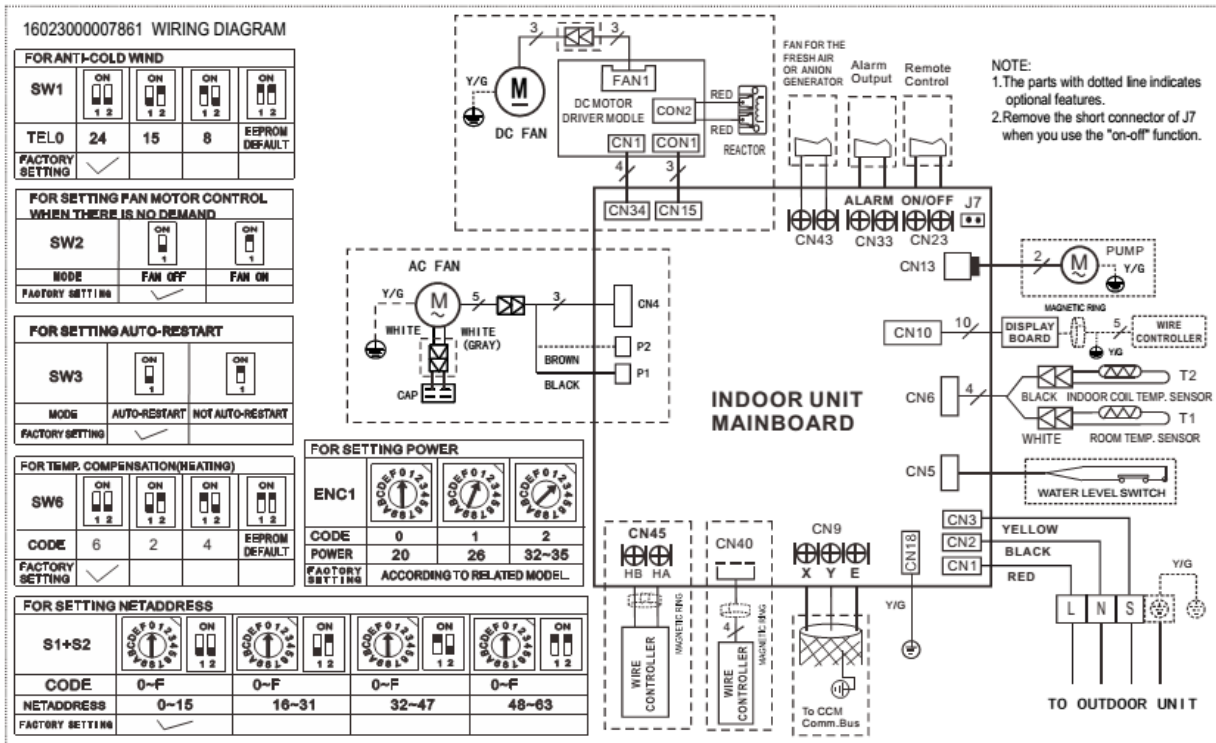

42QSS012D8S\*

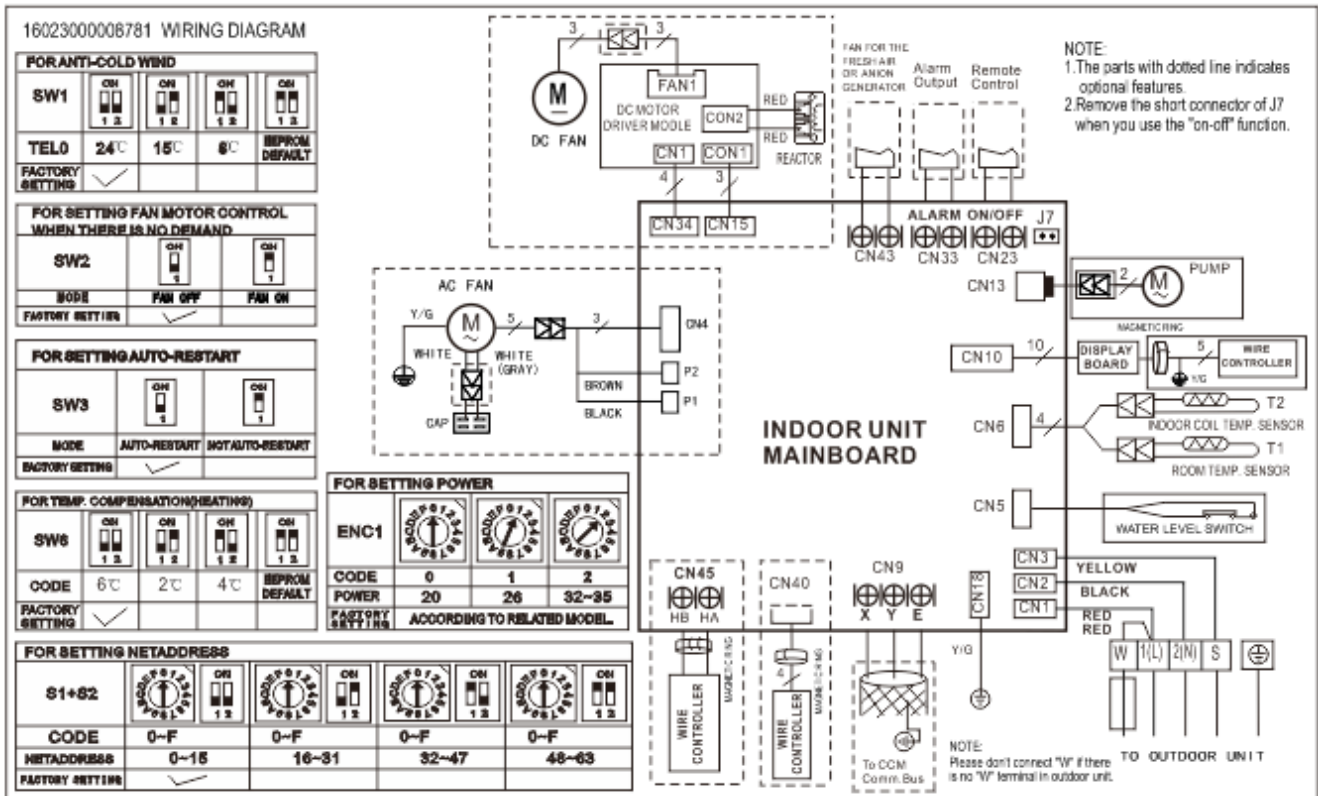



# 42QSS018D8S\*

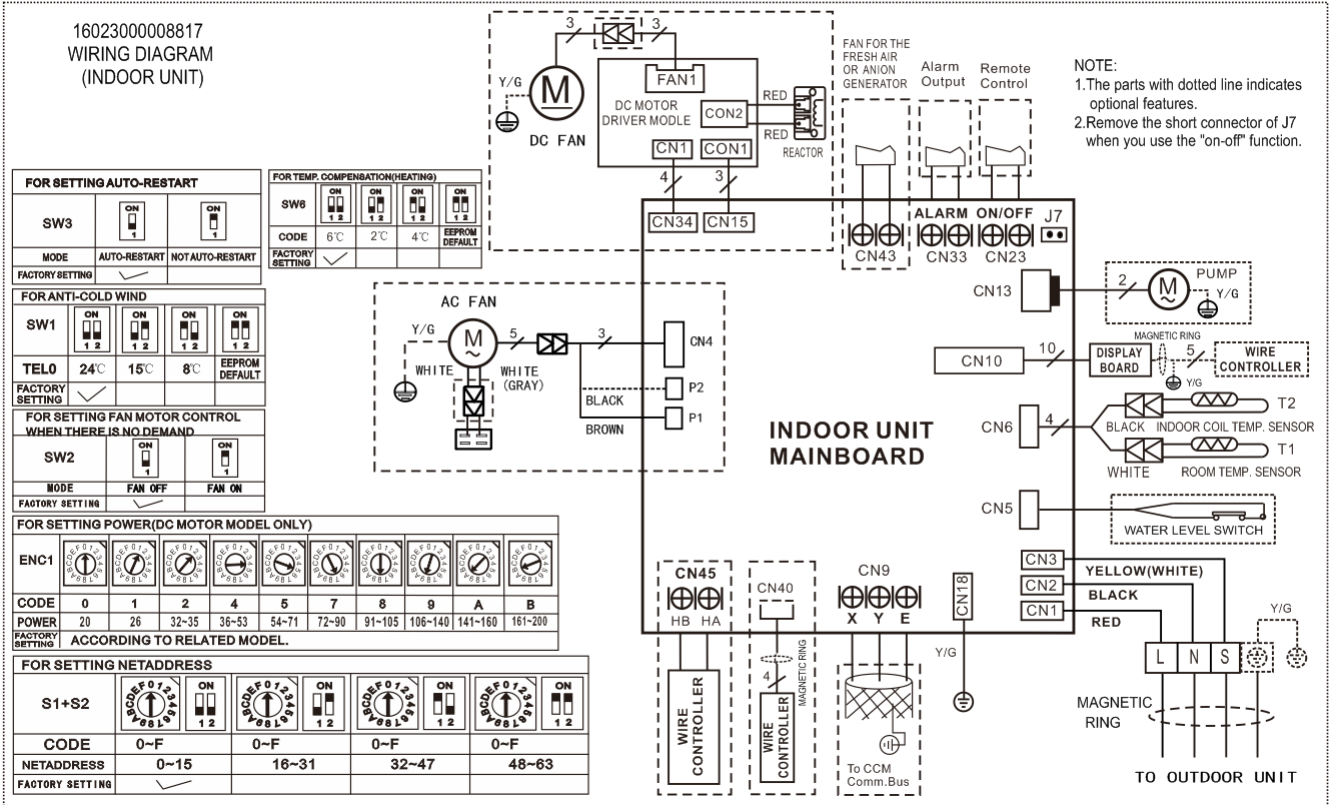

# 42QZA012D8S\*

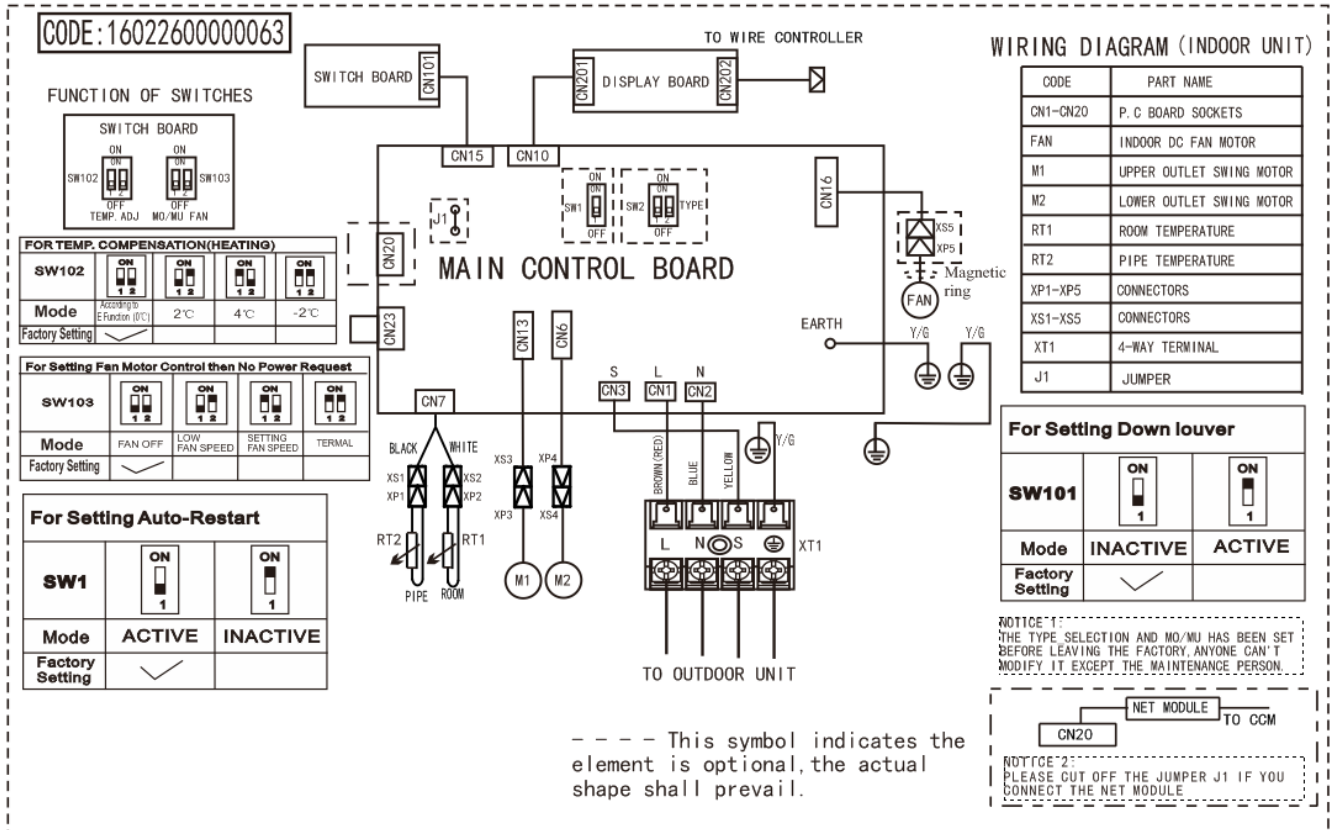

42QZL018D8S\*

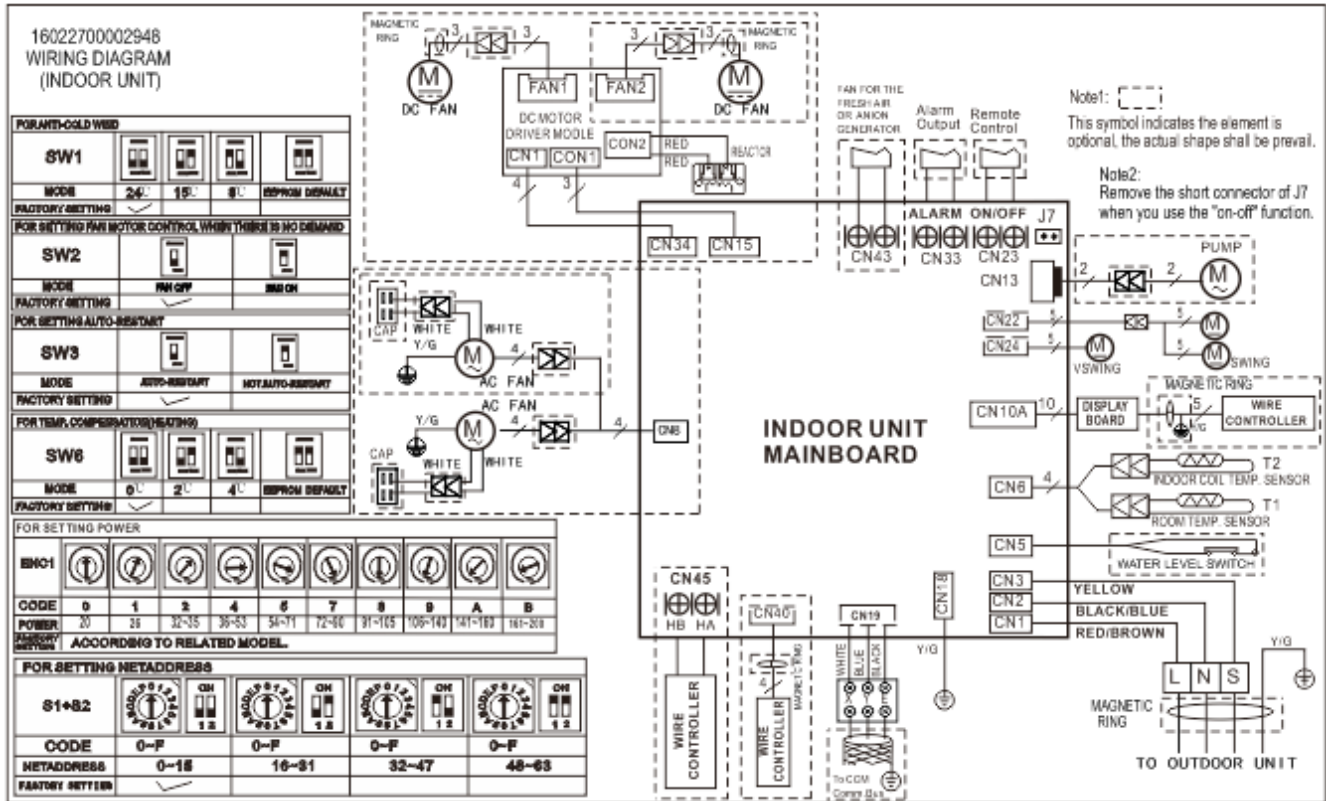

---

## 8. Indoor units combination

### 8.1 Indoor unit combination for 38QUS014D8S2\*

38QUS014D8S2		
One unit	Two unit	
7	7+7	9+9
9	7+9	9+12
12	7+12	
18		

### 8.2 Indoor unit combination for 38QUS018D8S2\*

38QUS018D8S2		
One unit	Two unit	
7	7+7	9+9
9	7+9	9+12
12	7+12	12+12
18		

### 8.3 Indoor unit combination for 38QUS021D8S3\*

38QUS021D8S3				
One unit	Two unit		Three unit	
7	7+7	9+9	7+7+7	9+9+9
9	7+9	9+12	7+7+9	
12	7+12	9+18	7+7+12	
18	7+18	12+12	7+9+9	

### 8.4 Indoor unit combination for 38QUS027D8S3\*

38QUS027D8S3						
One unit	Two unit			Three unit		
7	7+7	9+9	12+18	7+7+7	7+9+12	9+12+12
9	7+9	9+12		7+7+9	7+12+12	
12	7+12	9+18		7+7+12	9+9+9	
18	7+18	12+12		7+9+9	9+9+12	

8.5 Indoor unit combination for 38QUS028D8S4\*

38QUS028D8S4								
One unit	Two unit			Three unit			Four unit	
7	7+7	9+9	12+18	7+7+7	7+9+12	9+9+18	7+7+7+7	7+9+9+9
9	7+9	9+12	12+24	7+7+9	7+9+18	9+12+12	7+7+7+9	9+9+9+9
12	7+12	9+18	18+18	7+7+12	7+12+12	12+12+12	7+7+7+12	
18	7+18	9+24		7+7+18	9+9+9		7+7+9+9	
24	7+24	12+12		7+9+9	9+9+12		7+7+9+12	

8.6 Indoor unit combination for 38QUS036D8S4\*

38QUS036D8S4												
One unit	Two unit			Three unit					Four unit			
7	7+7	9+9	12+18	7+7+7	7+9+9	7+12+18	9+9+18	9+18+18	7+7+7+7	7+7+9+12	7+9+12+12	9+9+12+12
9	7+9	9+12	12+24	7+7+9	7+9+12	7+12+24	9+9+24	12+12+12	7+7+7+9	7+7+12+12	7+12+12+12	9+12+12+12
12	7+12	9+18	18+18	7+7+12	7+9+18	7+18+18	9+12+12	12+12+18	7+7+7+12	7+9+9+9	9+9+9+9	
18	7+18	9+24		7+7+18	7+9+24	9+9+9	9+12+18		7+7+7+18	7+9+9+12	9+9+9+12	
24	7+24	12+12		7+7+24	7+12+12	9+9+12	9+12+24		7+7+9+9	7+9+9+18	9+9+9+18	

8.7 Indoor unit combination for 38QUS042D8S5\*

38QUS042D8S5								
One Unit	Two Unit			Three Unit				
7	7+7	9+9	12+18	7+7+7	7+9+9	7+12+18	9+9+18	9+18+18
9	7+9	9+12	12+24	7+7+9	7+9+12	7+12+24	9+9+24	12+12+12
12	7+12	9+18	18+18	7+7+12	7+9+18	7+18+18	9+12+12	12+12+18
18	7+18	9+24		7+7+18	7+9+24	9+9+9	9+12+18	12+12+24
24	7+24	12+12		7+7+24	7+12+12	9+9+12	9+12+24	12+18+18
Four Unit								
7+7+7+7	7+7+9+9	7+7+12+18	7+9+9+18	7+9+18+18	9+9+9+18	9+12+12+12		
7+7+7+9	7+7+9+12	7+7+12+24	7+9+9+24	7+12+12+12	9+9+9+24	9+12+12+18		
7+7+7+12	7+7+9+18	7+7+18+18	7+9+12+12	7+12+12+18	9+9+12+12	12+12+12+12		
7+7+7+18	7+7+9+24	7+9+9+9	7+9+12+18	9+9+9+9	9+9+12+18	12+12+12+18		
7+7+7+24	7+7+12+12	7+9+9+12	7+9+12+24	9+9+9+12	9+9+12+24			
Five Unit								
7+7+7+7+7	7+7+7+9+12	7+7+12+12+12	7+9+9+12+12	9+9+9+12+12				
7+7+7+7+9	7+7+7+9+18	7+7+12+12+18	7+9+12+12+12	9+9+12+12+12				
7+7+7+7+12	7+7+9+9+9	7+9+9+9+9	9+9+9+9+9					
7+7+7+7+18	7+7+9+9+12	7+9+9+9+12	9+9+9+9+12					
7+7+7+9+9	7+7+9+9+18	7+9+9+9+18	9+9+9+9+18					

---

## 9. Operation temperature range

Mode \ Temperature	Cooling operation	Heating operation	Drying operation
Room temperature	17°C~32°C	0°C~27°C	17°C~32°C
Outdoor temperature	-10°C~50°C	-15°C~24°C	-10°C~50°C

### CAUTION:

1. If the air conditioner is used beyond the above conditions, certain safety protection features may come into operation and cause the unit to operate abnormally.
2. The room relative humidity should be less than 80%. If the air conditioner operates beyond this figure, the surface of the air conditioner may attract condensation. Please set the vertical air flow louver to its maximum angle (vertically to the floor), and set HIGH fan mode.
3. The optimum performance will be achieved during this operating temperature zone.

## 10. Electronic function

Note: Below function only for light commercial, for Hi-wall units, please refer to 1 drive 1 service manuals.

### 10.1 Abbreviation

T1: Indoor room temperature

T2: Indoor evaporator temperature

T2B: Coil temperature of indoor heat exchanger outlet (This sensor is located in outdoor unit)

T3: Coil temperature of outdoor heat exchanger

T4: Outdoor ambient temperature

T5: Compressor discharge temperature

Ts: Setting temperature

### 10.2 Icon explanation on indoor display board

#### 10.2.1 Four-way cassette (compact)

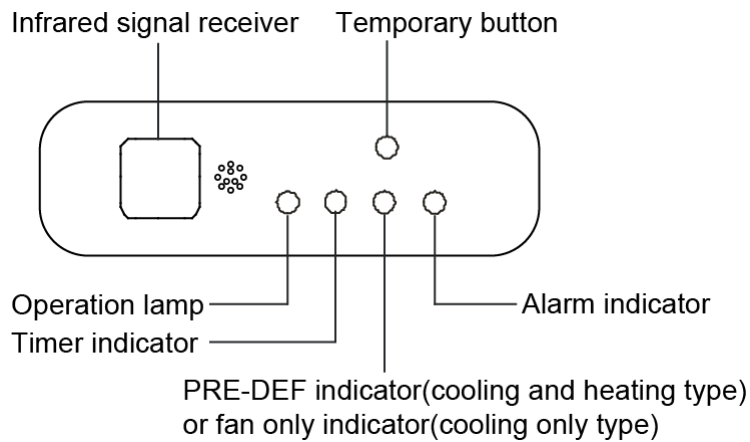

#### 10.2.2 A6 Ducted

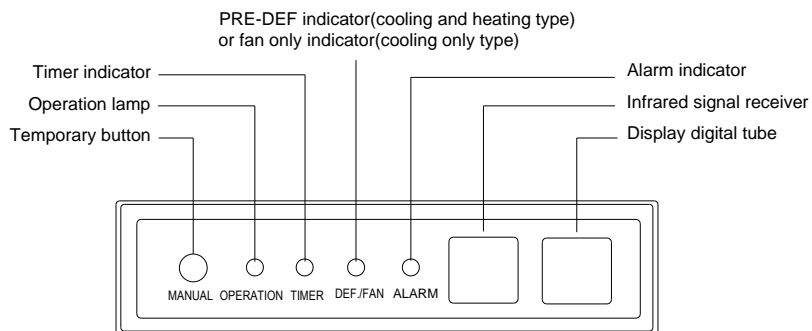

#### 10.2.3 Console

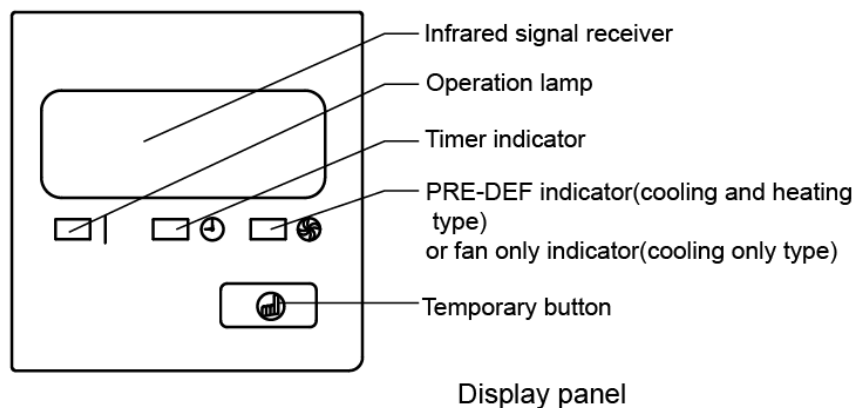

## 10.2.4 Under Ceiling

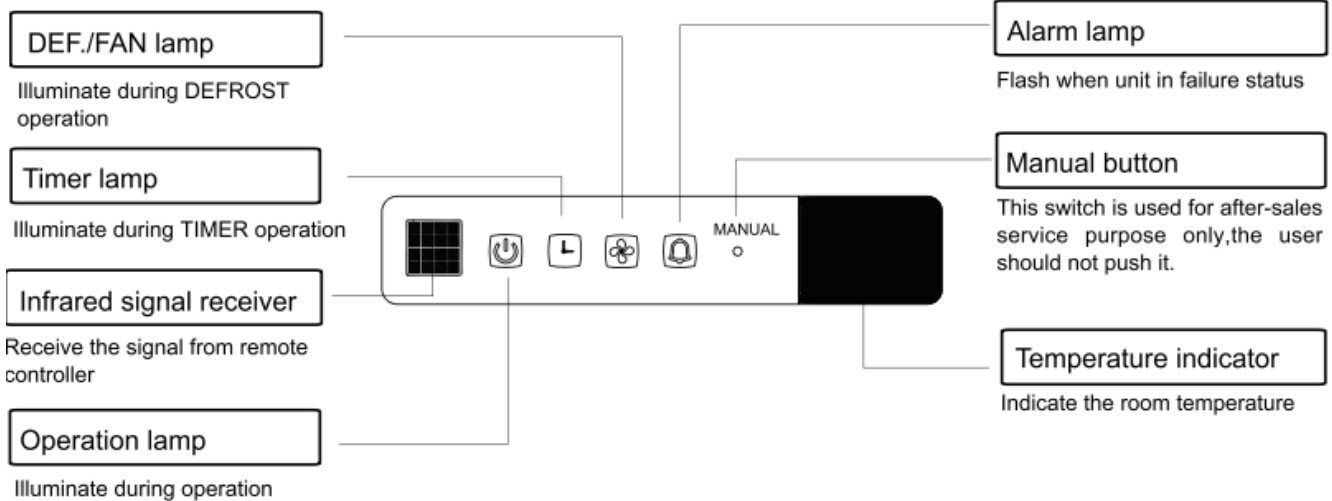

## 10.2.5 15C&AB



## 10.3 Main Protection

### 10.3.1 Three minutes delay at restart for compressor.

### 10.3.2 Sensor protection at open circuit and breaking disconnection.

### 10.3.3 Indoor fan delayed open function

---When system starts up, the louver will be active immediately, and the indoor fan will open after certain time.

---If the system runs in heating mode, the anti-cold wind function has priority.

### 10.3.4 Fan speed is out of control (For the units used DC fan motor)

For console:

When indoor fan speed keeps too low (300RPM) for certain time, the unit will stop and the LED will display the failure.

For other models:

When indoor fan speed keeps too low (lower than 300 RPM) for 50s, the indoor fan will shut off and restart 30s later, if protection happened 3 times when fan motor restart continuously, the unit will stop and the LED will display the failure.

### 10.3.5 Inverter module protection

The Inverter module has a protection function about current, voltage and temperature. If these protections happen, the corresponding code will display on indoor unit and the unit will stop working.



---

## 10.4 Operation Modes and Functions

### 10.4.1 Fan-only mode

(1) Outdoor fan and compressor stop.

(2) For Console: Indoor fan can be set to high/med/low/breeze, for other models: Indoor fan can be set to high/med/low/auto.

(3) The louver operates same as in cooling mode.

(4) Auto fan in fan-only mode acts as follow:

For all models:

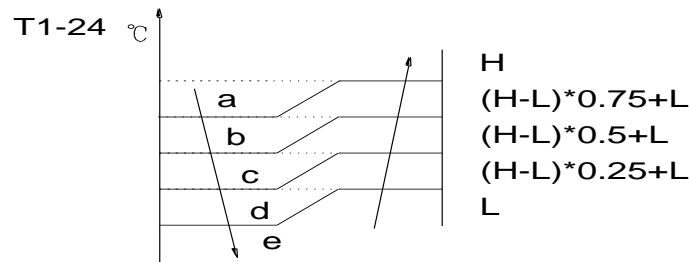

### 10.4.2 Cooling mode

#### 10.4.2.1 Outdoor fan running rules

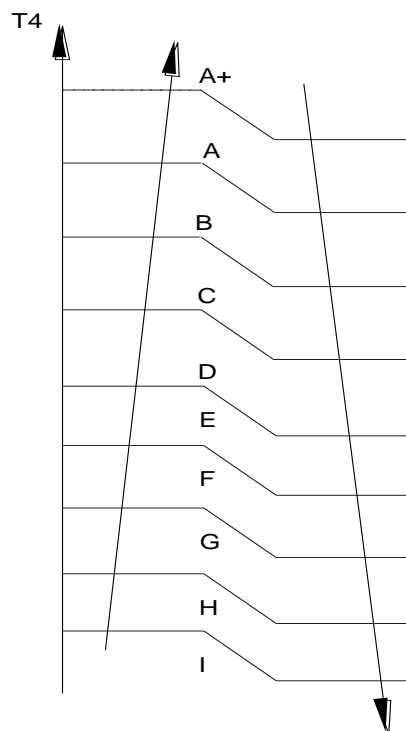

While A,B,C...means different fan speed of outdoor unit.

#### 10.4.2.2 Indoor fan running rules

For all models:

In cooling mode, indoor fan runs all the time and the speed can be selected as high, medium, low and auto.

When the compressor is running, the indoor fan is controlled as below:

Setting fan speed	T1-Td °C(°F)	Actual fan speed
H	A	H+ (H+=H+G)
	B	H (=H)
	C	H- (H-=H-G)
M	D	M+ (M+=M+Z)
	E	M(M=M)
	F	M- (M-=M-Z)
L	G	L+ (L+=L+D)
	H	L(L=L)
	I	L- (L-=L-D)

The auto fan acts as below rules:

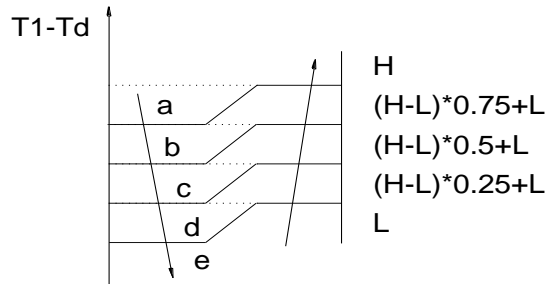

### 10.4.2.3 Evaporator low temperature T2 protection

For all models: When  $T_2 < 4^\circ\text{C}$  for 250s or  $T_2 < 0^\circ\text{C}$ , the indoor has no capacity demand and resume till  $T_2 > 8^\circ\text{C}$

### 10.4.3 Dry mode

8.4.3.1 Indoor fan speed is fixed at breeze and can't be changed. The louver angle is the same as in cooling mode.

8.4.3.2 Low indoor room temperature protection

In drying mode, if room temperature is lower than  $10^\circ\text{C}$ , the indoor fan will stop and not resume until room temperature exceeds  $12^\circ\text{C}$ .

784.3.3 Evaporator anti-freezing protection and condenser high temperature protection are active and the same as that in cooling mode.

8.4.3.4 The outdoor fan operates the same as in cooling mode.

### 10.4.4 Heating mode

#### 10.4.4.1 Outdoor fan running rules

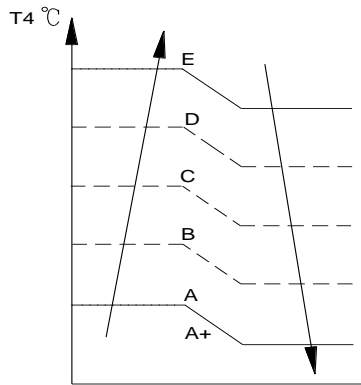

### 10.4.4.2 Indoor fan running rules

For all models:

In heating mode, indoor fan can be selected as high, medium, low and auto. The anti-cold-wind function has the priority.

When the compressor is running, the indoor fan is controlled as below:

Setting fan speed	T1-Td°C	Actual fan speed
H		H- (H=H-G)
		H (=H)
		H+(H+=H+G)
M		M-(M=M-Z)
		M(M=M)
		M+(M+=M+Z)
L		L-(L=L-D)
		L(L=L)
		L+(L+=L+D)

If the compressor stops caused by the room temperature rising, the indoor fan will be forced to run 127 seconds with breeze. During this period, the anti-cold-wind is disabled.

Auto fan action in heating mode:

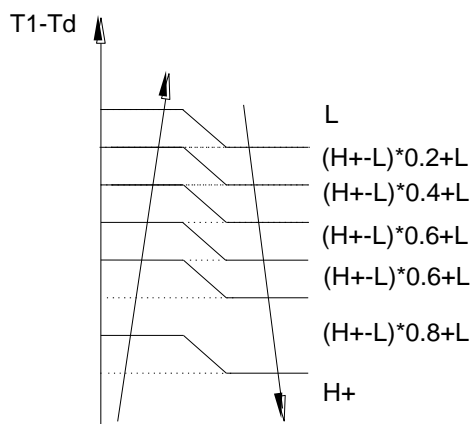

### 10.4.4.3 High evaporator coil temp.T2 protection:

If  $T_2 > 63^\circ\text{C}$ , the indoor unit has no capacity demand and resume till  $48^\circ\text{C}$ .

### 10.4.4.4 Prevent Over-Heating

In heating mode, when the indoor unit has no capacity requirement due to indoor room temperature increased, the Indoor fan will run in super breeze. (Anti-cold wind function has the priority)

**10.4.4.5 Defrosting mode:**

**Condition of defrosting:**

AC will enter the defrosting mode according to the value of temp. of T3 and the value range of temp. change of T3 and also the compressor running time.

**Condition of ending defrosting:**

If any one of the following items is satisfied, the defrosting will finish and the machine will turn to normal heating mode.

- T3 rises to be higher than TCDE1°C.
- T3 keeps to be higher than TCDE2°C for 80 seconds.
- The machine has run for 10 minutes in defrosting mode.

**Defrosting action:**

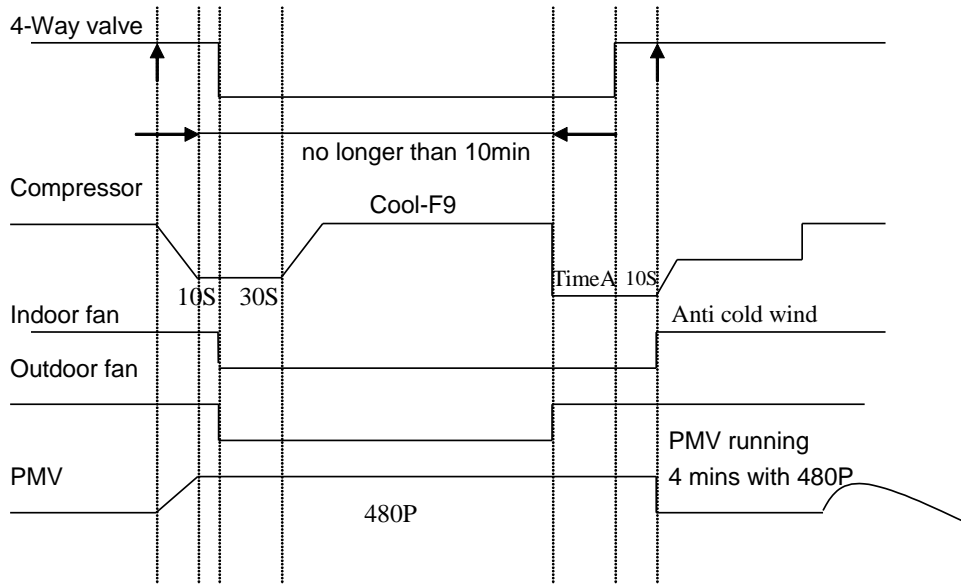

**10.4.5 Auto-mode**

This mode can be chosen by remote controller and the setting temperature can be changed between 17~30°C.

In auto mode, the machine will choose cooling, heating or fan-only mode according to the difference between T1 and TS.

For all models:

T1-TS	Running mode
$T1-TS > 2^{\circ}\text{C}$	Cooling
$-2 < T1-TS \leq 2^{\circ}\text{C}$	Fan-only
$T1-TS \leq -2^{\circ}\text{C}$	Heating

Indoor fan will run at auto fan of the relevant mode.

The louver operates same as in relevant mode.

If the machine switches mode between heating and cooling, the compressor will keep stopping for 15 minutes and then choose mode according to T1-Ts.

---

If the setting temperature is modified, the machine will choose running function again.

### 10.4.6 Forced operation function

10.4.6.1 Enter forced operation function:

Press the touch button continually, the AC will run as below sequence:

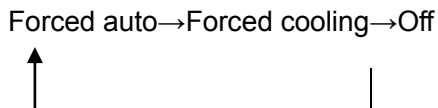

When the machine is off, pressing the touch button will carry the machine to forced auto mode, after this, if pressing the button once again, the machine will turn into forced cooling mode.

In forced cooling mode, pressing touch button will turn off the machine.

10.4.6.2 In forced operation mode, all general protections and remote control are available.

10.4.6.3 Operation rules:

Forced cooling mode:

The compressor runs at F2 frequency and indoor fan runs as breeze. After running for 30 minutes. the machine will turn to auto mode as 24°C setting temperature.

Forced auto mode:

The action of forced auto mode is the same as normal auto mode with 24°C setting temperature.

10.4.6.4 When there's indoor unit running in forced cooling, it is the master forced cooling unit. Other indoor units will run at forced cooling mode too and they will be the slave forced cooling units. The slave forced cooling units can not quit forced cooling mode until the master forced cooling unit quit, and turn to cooling mode at low speed with 24°C setting temperature.

10.4.6.5 The slave forced cooling units will not be controlled by other signals.

### 10.4.7 Timer Function

10.4.7.1 Timing range is 24 hours.

10.4.7.2 Timer on. The machine will turn on automatically when reaching the setting time.

10.4.7.3 Timer off. The machine will turn off automatically when reaching the setting time.

10.4.7.4 Timer on/off. The machine will turn on automatically when reaching the setting "on" time, and then turn off automatically when reaching the setting "off" time.

10.4.7.5 Timer off/on. The machine will turn off automatically when reaching the setting "off" time, and then turn on automatically when reaching the setting "on" time.

10.4.7.6 The timer function will not change the AC current operation mode. Suppose AC is off now, it will not start up firstly after setting the "timer off" function. And when reaching the setting time, the timer LED will be off and the AC running mode has not been changed.

10.4.7.7 The setting time is relative time.

### 10.4.8 Sleep mode

---

10.4.8.1 The sleep function is available in cooling, heating or auto mode.

10.4.8.2. Operation process in sleep mode is as follow.

After pressing ECONOMIC or SLEEP button on controller, the machine will turn into sleep mode.

When cooling, The set temperature rise 1°C per hour (be lower than 30°C). Two hours later, the set temperature will maintain as a constant and the fan speed is kept at low speed.

When heating, The set temperature decrease 1°C per hour (be higher than 17°C). Two hours later, the set temperature will maintain as a constant and the fan speed is kept at low speed (Anti-cold function takes precedence over all).

When auto, After an hour running under economic mode, if it is under cooling mode the set temp will rise 1°C, if it is under heating mode the set temp will decrease 1°C, if it is under fan-only mode the set temp will be changeless; the condition will be the same after the air conditioner running under economic mode after 2 hours, and during the next time the set temp do not change.

10.4.8.3 Operation time in sleep mode is 7 hours. After 7 hours the AC quits this mode and the AC will turn off.

10.4.8.4 Timer off and remote controller off signals have the priority compared with sleep function.

#### **10.4.9 Auto-Restart function**

The indoor unit is equipped with auto-restart function, which is carried out through an auto-restart module. In case of a sudden power failure, the module memorizes the setting conditions before the power failure. The unit will resume the previous operation setting (not including swing function) automatically after 3 minutes when power returns.

If the memorization condition is forced cooling mode, the unit will run in cooling mode for 30 minutes and turn to auto mode as 24°C setting temp.

If AC is off before power off and AC is required to start up now, the compressor will have 1 minute delay when power on. Other conditions, the compressor will have 3 minutes delay when restarts.

#### **10.4.10 Drain pump control (For A5 Duct & Cassette)**

Adopt the water-level switch to control the action of drain pump.

Main action under different condition : ( every 5 seconds the system will check the water level one time)

1. When the A/C operates with cooling (including auto cooling) and forced cooling mode or dry mode, the pump will start running immediately and continuously, till stop cooling or dry or no capacity demand.

2. Once the water level increase and up to the control point, LED will alarm and the drain pump open and continue checking the water level. If the water level falls down below the control point (drain pump delay close 1 minute) and operate with the last mode. Otherwise the entire system stop operating (including the pump) and LED remain alarming after 3 minutes,

#### **10.4.11 Follow me (optional)**

- 1) If the indoor PCB receives the signal which results from pressing the FOLLOW ME button on remote controller, the buzzer will emit a sound and this indicates the follow me function is initiated. But when the indoor PCB receives signal which sent from remote controller every 3 minutes, the buzzer will not respond. When the unit is running with follow-me function, the PCB will control the unit according to the temperature from follow-me signal, and the temperature collection function of room temperature sensor will be shielded, and the error detective function of room temperature sensor will be still invalid.
- 2) When the follow-me function is available, the PCB will not respond according to the setting temperature from follow-me signal every 3 minutes.
- 3) The PCB will take action to the mode change information from remote controller signal, and the follow-me function will be turned off. (if the wired remote controller does not initiate follow me function).
- 4) When the unit is running with follow-me function, if the PCB doesn't receive any signal from remote controller for 7 minutes or pressing FOLLOW ME button again, the follow-me function will be turned off automatically, and the temperature collection function of room temperature sensor will be available, the PCB will control the unit according to the room temperature detected from its own room temperature sensor and setting temperature.
- 5) When the indoor PCB receives the follow-me signal from wired remote controller, the control is the same as that from wireless remote controller, but buzzer will not emit a sound. When the PCB receives turning-off follow-me signal from wired remote controller, the unit will quit follow-me function at once. The follow-me function controlled by wired remote controller prevails that by wireless remote controller.

#### 10.4.12 Mode conflict

The indoor units can not work cooling mode and heating at same time.

Heating mode has a priority.

##### (1) Definition

	Cooling mode	Heating Mode	Fan	Off
Cooling mode	No	Yes	No	No
Heating Mode	Yes	No	Yes	No
Fan	No	Yes	No	No
Off	No	No	No	No

No: No mode conflict;

Yes: Mode conflict

##### (2) Unit action

- In case of one Indoor unit working in cooling mode or fan mode, and another indoor unit is set to heating mode, the indoor unit working in cooling mode or fan mode will change to off. The outdoor unit will change to heating mode after compressor stop 3 minutes. .
- In case of one Indoor unit working in heating mode, and another indoor unit is set to cooling mode or fan mode, the indoor unit setting to cooling mode or fan mode will change to stand by. The outdoor unit will continue working in heating mode.

If heating mode stops (not including the indoor unit in heating mode reaching the set temperature), 3 minutes after the outdoor unit restarts and works in cooling mode or fan-only mode.

---

## 11. General information of Outdoor Units

<b>Model name</b>	<b>Dimension (mm)</b>	<b>Compressor</b>
38QUS014D8S2*	800x333x554	KSN140D21UFZ
38QUS018D8S2*	800x333x554	KSN140D21UFZ
38QUS021D8S3*	845x363x702	KSN140D21UFZ
38QUS027D8S3*	845x363x702	KTM240D57UMT
38QUS028D8S4*	946x410x810	KTM240D57UMT
38QUS036D8S4*	946x410x810	KTF310D43UMT
38QUS042D8S5*	946x410x810	KTF310D43UMT



---

## 12. Features

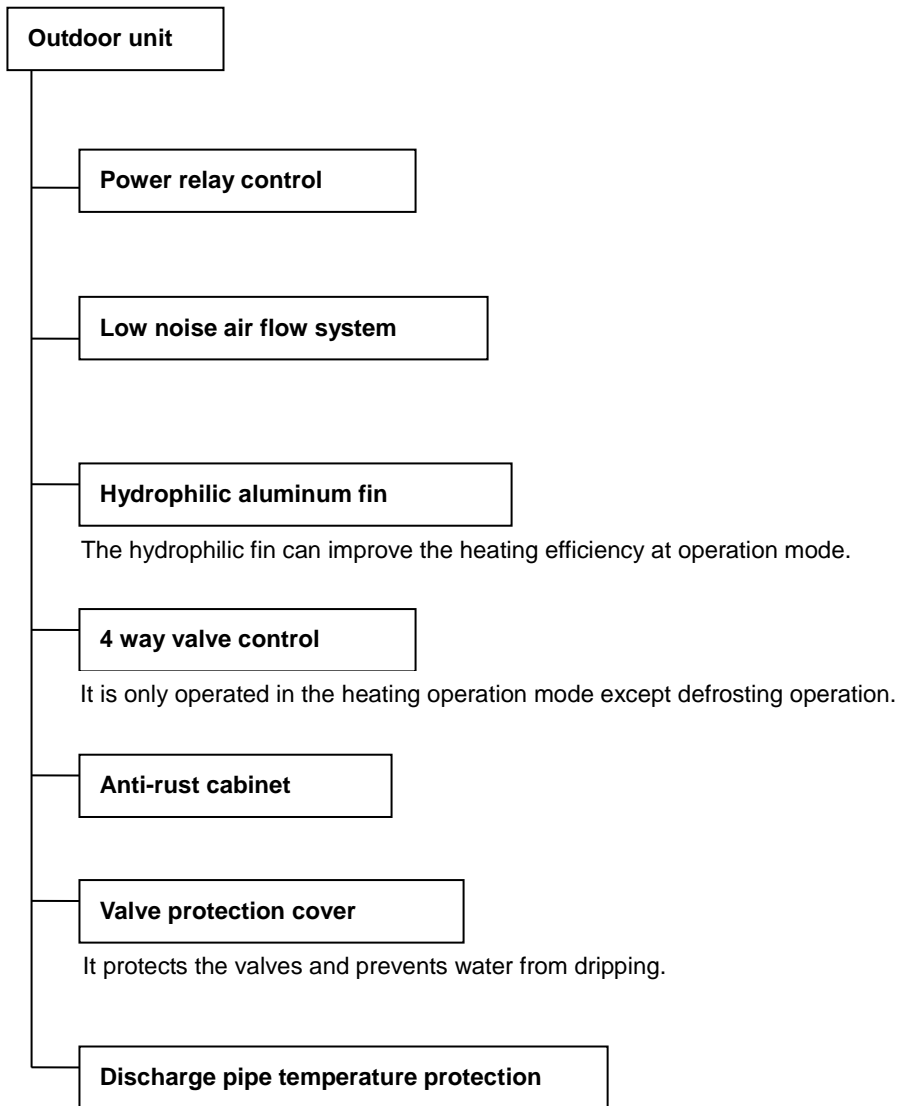

## 13. Dimensions

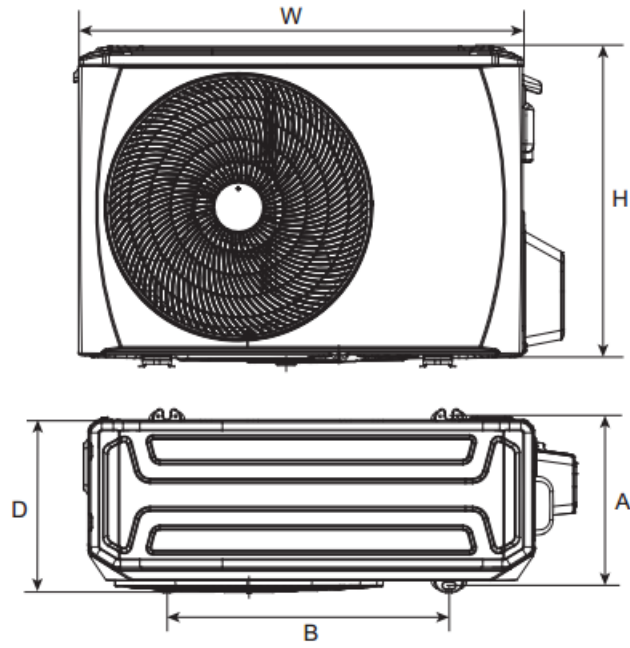

Model	Unit: mm					
	W	D	H	W1	A	B
38QUS014D8S2*	800	333	554	860	514	340
38QUS018D8S2*	800	333	554	860	514	340
38QUS021D8S3*	845	363	702	923	540	350
38QUS027D8S3*	845	363	702	923	540	350
38QUS028D8S4*	946	410	810	1034	673	403
38QUS036D8S4*	946	410	810	1034	673	403
38QUS042D8S5*	946	410	810	1034	673	403

# 14. Refrigeration Cycle Diagram

## 14.1 Refrigeration circuit drawing of inverter 1 drive 2 type

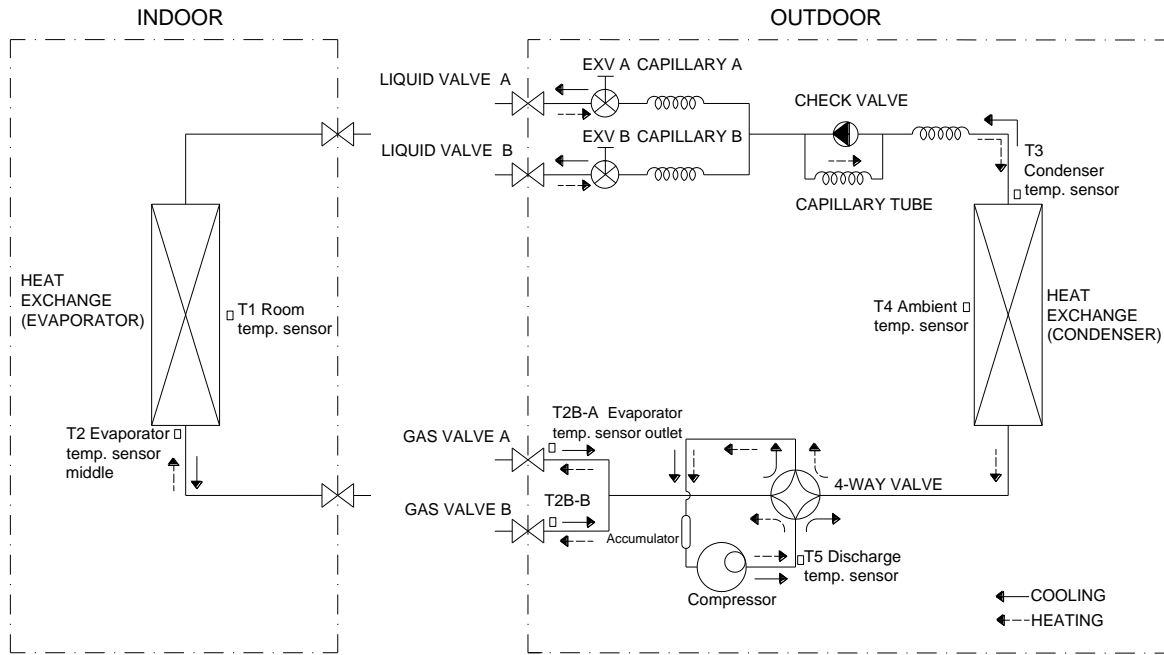

## 14.2 Refrigeration circuit drawing of inverter 1 drive 3 type

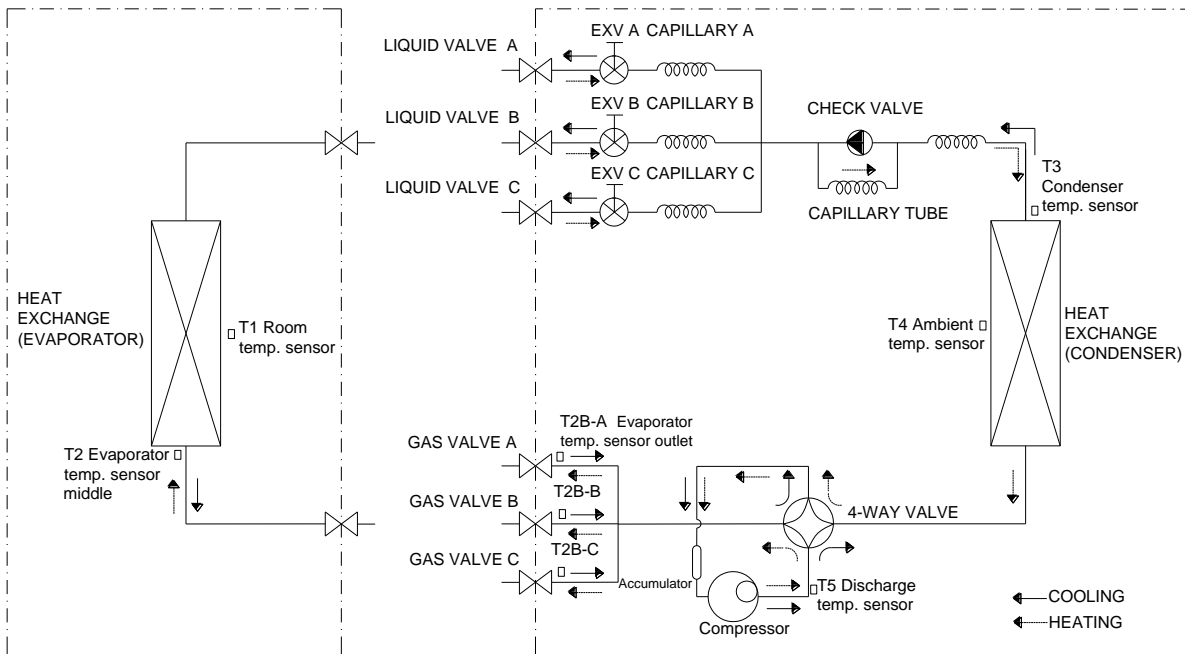

### 14.3 Refrigeration circuit drawing of inverter 1 drive 4 type

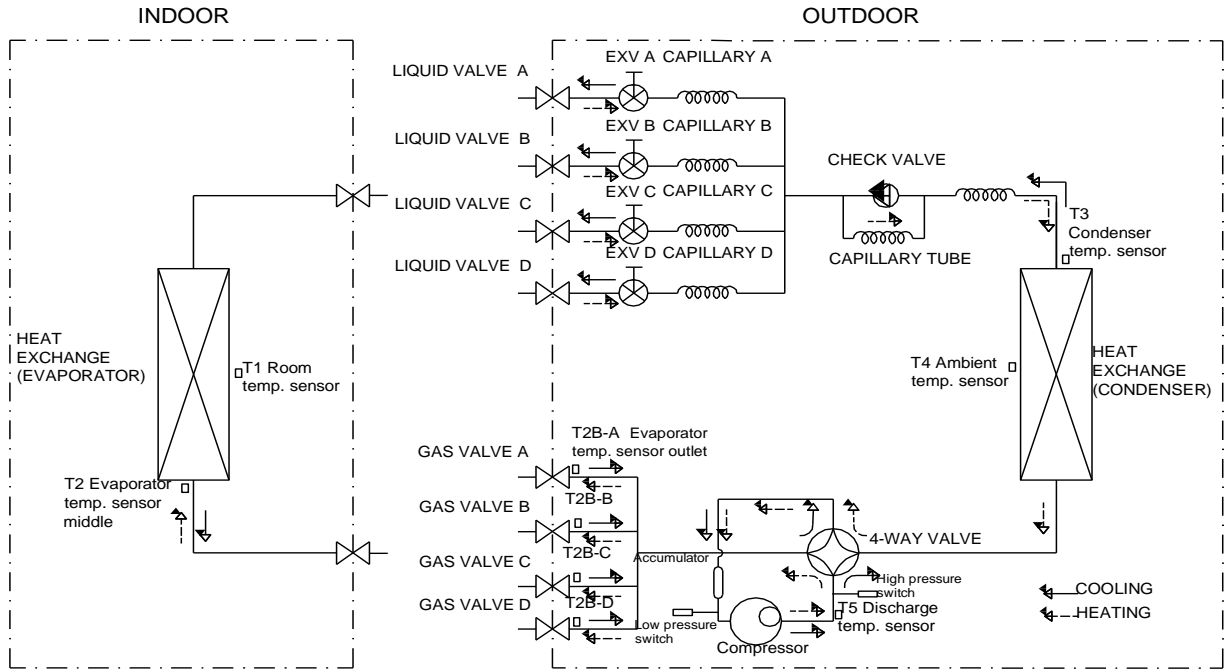

### 14.4 Refrigeration circuit drawing of inverter 1 drive 5 type

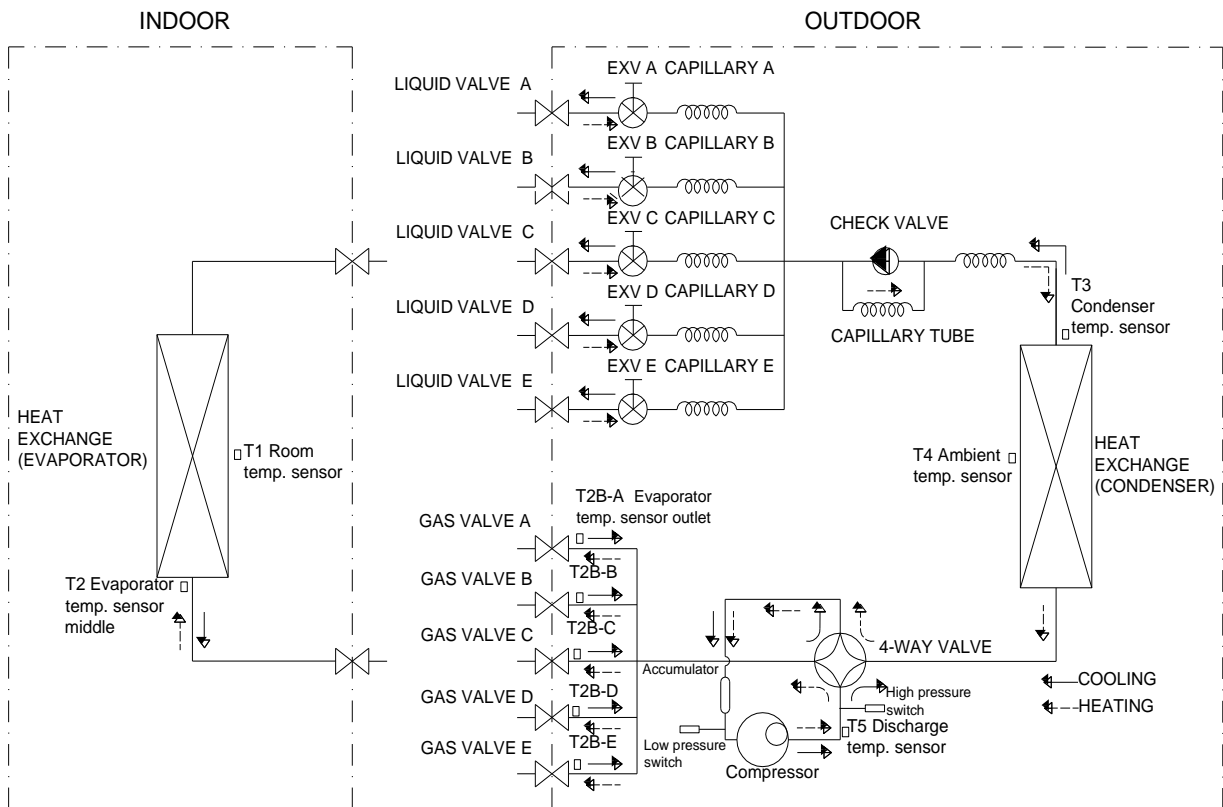

## 15 Sound Levels

Outdoor Unit

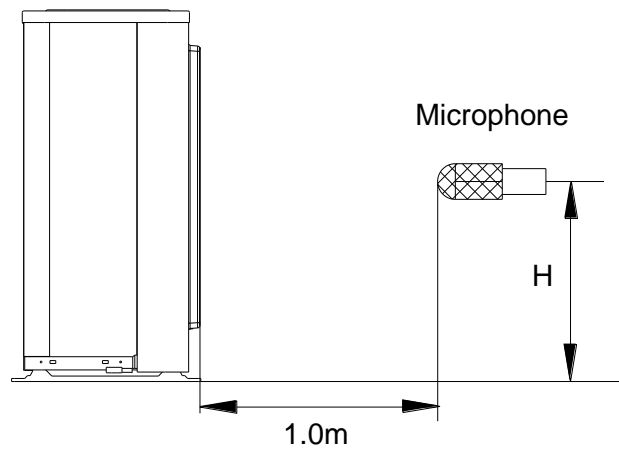

**Note:**  $H = 0.5 \times$  height of outdoor unit

Model	Noise Power dB(A)	Noise level dB(A)
38QUS014D8S2*	65	56
38QUS018D8S2*	65	56
38QUS021D8S3*	66	58
38QUS027D8S3*	68	60
38QUS028D8S4*	70	63
38QUS036D8S4*	72	64
38QUS042D8S5*	72	64

## 16 Installation Details

### 16.1 Wrench torque sheet for installation

Outside diameter	Torque	Additional tightening torque
mm	N.cm	N.cm
Φ6.35	1500(153kgf.cm)	1600(163kgf.cm)
Φ9.52	2500(255kgf.cm)	2600(265kgf.cm)
Φ12.7	3500(357kgf.cm)	3600(367kgf.cm)

### 16.2 Connecting the cables

The power cord of connect should be selected according to the following specifications sheet.

Rated current of appliance	Nominal cross-sectional area (mm <sup>2</sup> )
>3 and ≤6	0.75
>6 and ≤10	1
>10 and ≤16	1.5
>16 and ≤25	2.5

The cable size and the current of the fuse or switch are determined by the maximum current indicated on the nameplate which located on the side panel of the unit. Please refer to the nameplate before selecting the cable, fuse and switch.

### 16.3 Pipe length and the elevation

#### Maximum piping length and height difference

Model (Btu/h)	1 drive 2		1 drive 3		1 drive 4		1 drive 5
	14K	18K	21K	27K	28K	36K	42K
Max. length for all rooms (m)	40	40	60	60	80	80	80
Max. length for one IU (m)	25	25	25	30	30	35	35
Max. height difference between IU and OU (m)	15	15	15	15	15	15	15
Max. height difference between IUs (m)	10	10	10	10	10	10	10

#### Additional refrigerant charge

	1 drive 2	1 drive 3	1 drive 4	1 drive 5
Chargeless pipe length (m)	15	22.5	30	37.5
Additional refrigerant charge (g)	12 x (length for all rooms - 15)	12 x (length for all rooms - 22.5)	12 x (length for all rooms - 30)	12 x (length for all rooms - 37.5)

Caution:

- Refrigerant pipe diameter is different according to indoor unit to be connected. When using the extension pipe, refer to the tables below.
- When refrigerant pipe diameter is different from that of outdoor unit union (for 18K&24K indoor unit), additional transfer connector needs to be used on outdoor unit union.

Indoor unit		Extension pipe diameter (mm/inch)		
Model	Pipe diameter (mm/inch)			
7K9K12K	Liquid	6.35(1/4)	Liquid	6.35(1/4)
	Gas	9.52(3/8)	Gas	9.52(3/8)
18K	Liquid	6.35(1/4)	Liquid	6.35(1/4)
	Gas	12.7(1/2)	Gas	12.7(1/2)
24K	Liquid	9.52(3/8)	Liquid	9.52(3/8)
	Gas	15.9(5/8)	Gas	15.9(5/8)
Outdoor unit union diameter (mm/inch)				
1 drive 2			Liquid	6.35(1/4) *2
			Gas	9.52(3/8) *2
1 drive 3			Liquid	6.35(1/4) *3
			Gas	9.52(3/8) *3
1 drive 4			Liquid	6.35(1/4) *4
			Gas	9.52(3/8) *3
				12.7(1/2) *1
1 drive 5			Liquid	6.35(1/4) *5
			Gas	9.52(3/8) *4
				12.7(1/2) *1

#### 16.4 Installation for the first time

Air and moisture in the refrigerant system have undesirable effects as below:

- Pressure in the system rises.
- Operating current rises.
- Cooling or heating efficiency drops.
- Moisture in the refrigerant circuit may freeze and block capillary tubing.
- Water may lead to corrosion of parts in the refrigerant system.

Therefore, the indoor units and the pipes between indoor and outdoor units must be leak tested and evacuated to remove gas and moisture from the system.

Gas leak check (Soap water method):

Apply soap water or a liquid neutral detergent on the indoor unit connections or outdoor unit connections by a soft brush to check for leakage of the connecting points of the piping. If bubbles come out, the pipes have leakage.

### 1. Air purging with vacuum pump

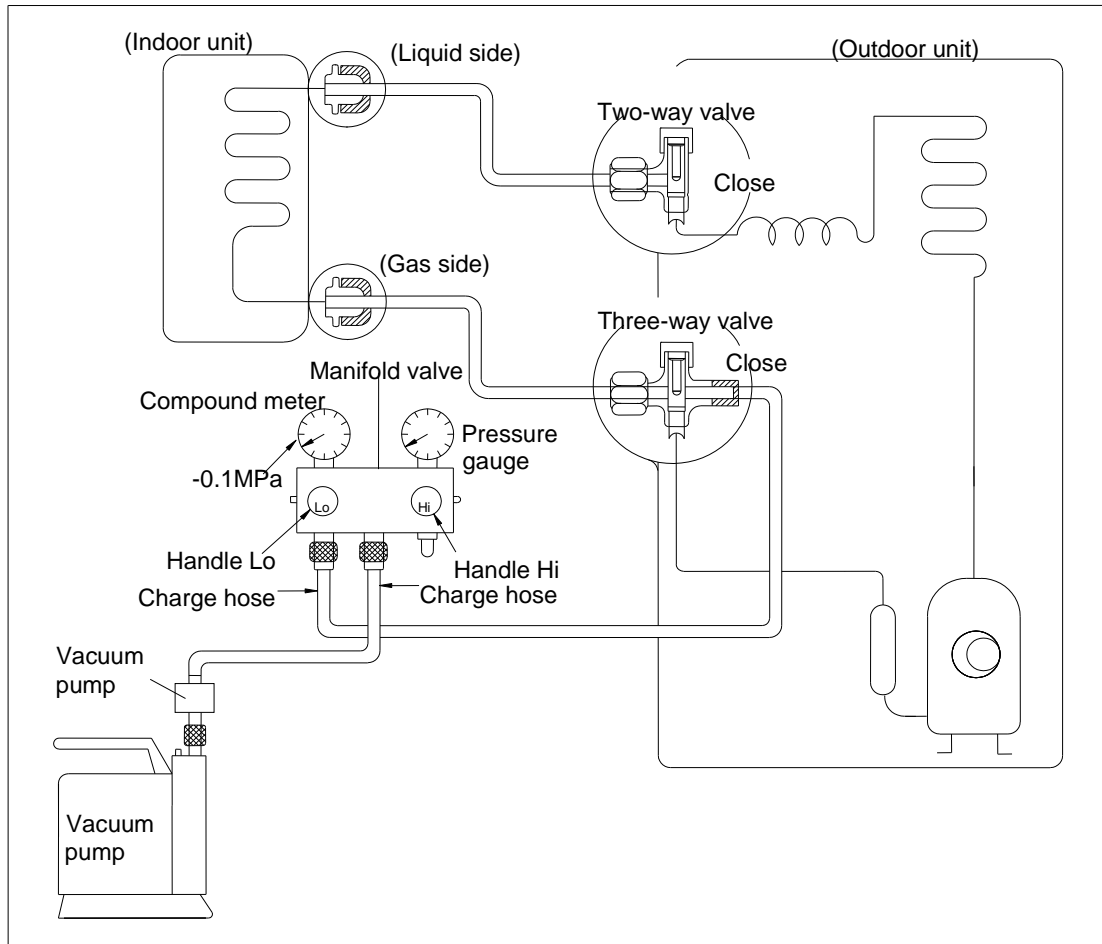

- 1) Completely tighten the flare nuts of the indoor and outdoor units, confirm that both the 2-way and 3-way valves are set to the closed position.
- 2) Connect the charge hose with the push pin of handle lo to the 3-way valves gas service port..
- 3) Connect the charge hose of handle hi connection to the vacuum pump.
- 4) Fully open the handle Lo of the manifold valve.
- 5) Operate the vacuum pump to evacuate.
- 6) Make evacuation for 30 minutes and check whether the compound meter indicates -0.1Mpa. If the meter does not indicate -0.1Mpa after pumping 30 minutes, it should be pumped 20 minutes more. If the pressure can't achieve -0.1Mpa after pumping 50 minutes, please check if there are some leakage points. Fully close the handle Lo valve of the manifold valve and stop the operation of the vacuum pump. Confirm that the gauge needle does not move (approximately 5 minutes after turning off the vacuum pump).
- 7) Turn the flare nut of the 3-way valves about 45° counterclockwise for 6 or 7seconds after the gas coming out, then tighten the flare nut again. Make sure the pressure display in the pressure indicator is a little higher than the atmosphere pressure. Then remove the charge hose from the 3 way valve.
- 8) Fully open the 2 way valve and 3 way valve and securely tighten the cap of the 3 way valve.



## 2. Adding the refrigerant if the pipe length >5m

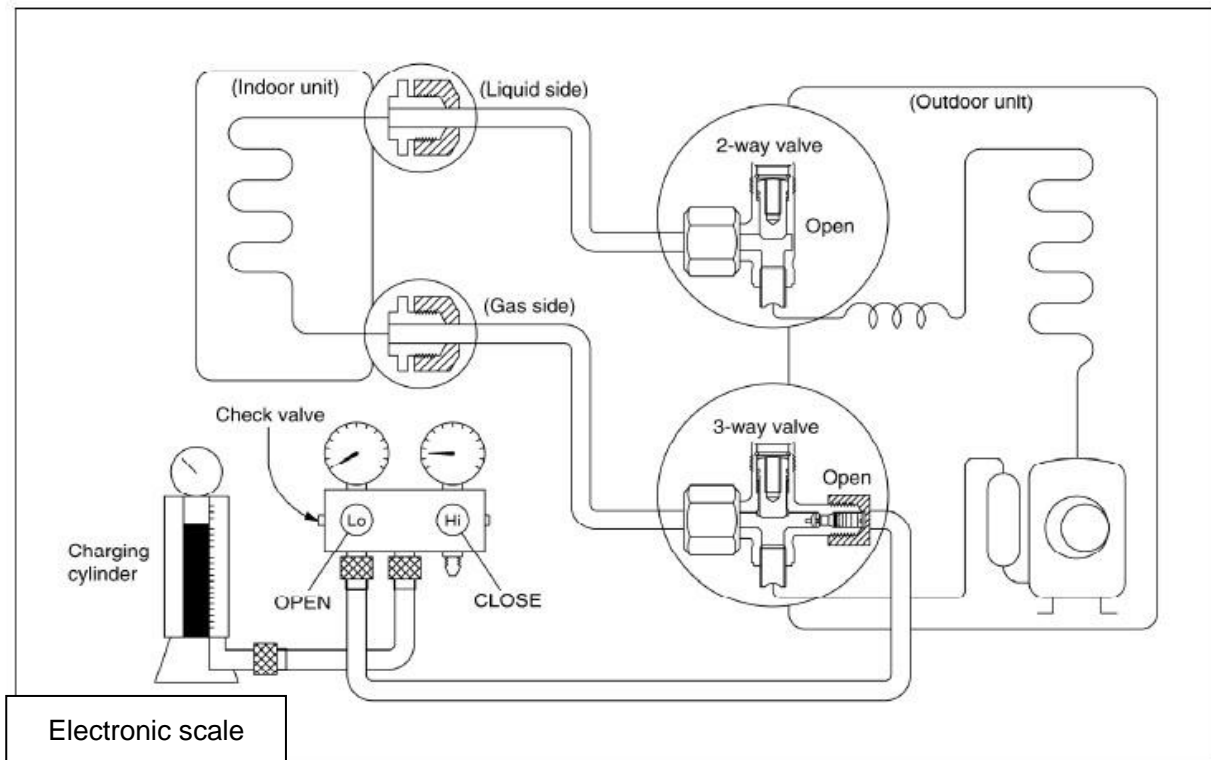

### Procedure:

1). Connect the charge hose to the charging cylinder, open the 2-way valve and the 3-way valve.

Connect the charge hose which you disconnected from the vacuum pump to the valve at the bottom of the cylinder. If the refrigerant is R410A, make the cylinder bottom up to ensure the liquid charge.

2). Purge the air from the charge hose.

Open the valve at the bottom of the cylinder and press the check valve on the charge set to purge the air (be careful of the liquid refrigerant).

3) Put the charging cylinder onto the electronic scale and record the weight.

4) Operate the air conditioner at the cooling mode.

5) Open the valves (Low side) on the charge set and charge the system with liquid refrigerant.

6).When the electronic scale displays the proper weight (refer to the table), disconnect the charge hose from the 3-way valve's service port immediately and turn off the air conditioner before disconnecting the hose.

7). Mount the valve stem caps and the service port

Use torque wrench to tighten the service port cap to a torque of 18N.m.

Be sure to check for gas leakage.

## 16.5 Adding the refrigerant after running the system for many years

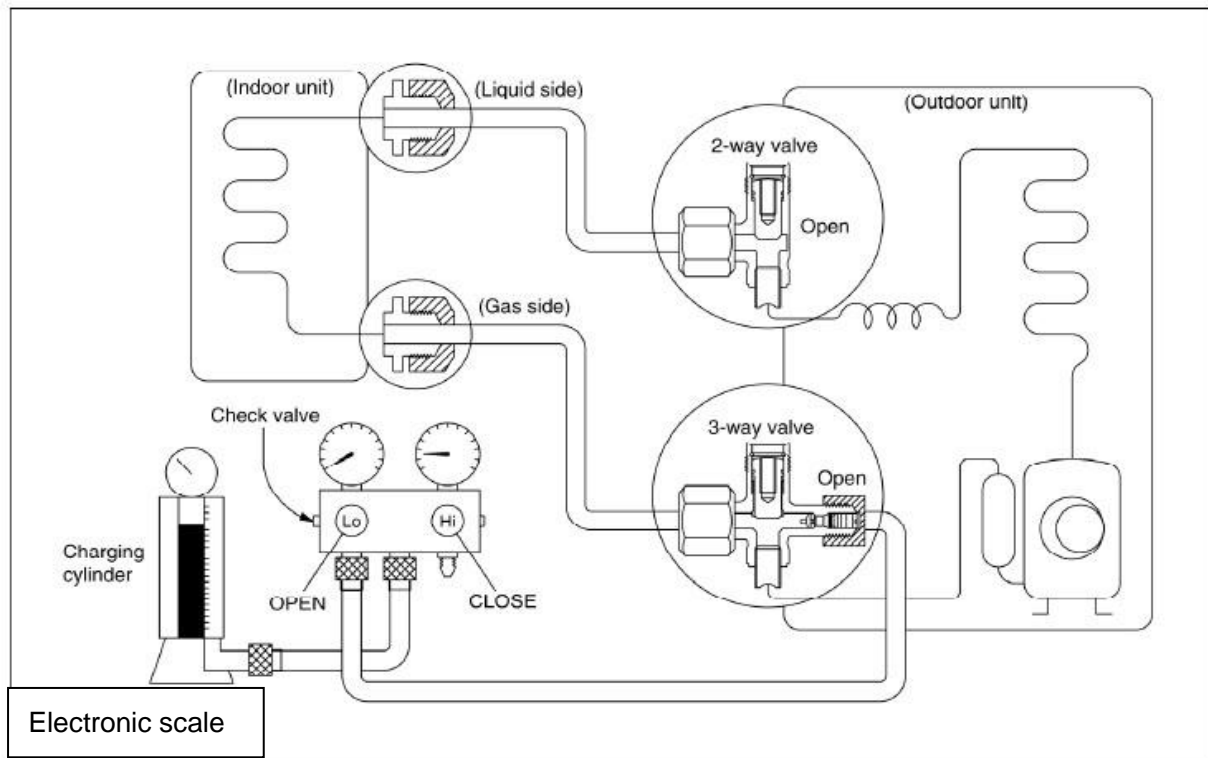

### Procedure:

1). Connect the charge hose to the 3-way service port, open the 2-way valve and the 3-way valve.

Connect the charge hose to the valve at the bottom of the cylinder. If the refrigerant is R410A, make the cylinder bottom up to ensure liquid charge.

2). Purge the air from the charge hose.

Open the valve at the bottom of the cylinder and press the check valve on the charge set to purge the air (be careful of the liquid refrigerant).

3) Put the charging cylinder onto the electronic scale and record the weight.

4) Operate the air conditioner at the cooling mode.

5) Open the valves (Low side) on the charge set and charge the system with liquid refrigerant.

6).When the electronic scale displays the proper weight (refer to the gauge and the pressure of the low side), disconnect the charge hose from the 3-way valve's service port immediately and turn off the air conditioner before disconnecting the hose.

7). Mount the valve stem caps and the service port

Use torque wrench to tighten the service port cap to a torque of 18N.m.

Be sure to check for gas leakage.

## 16.6 Re-installation while the indoor unit need to be repaired

### 1. Collecting the refrigerant into the outdoor unit

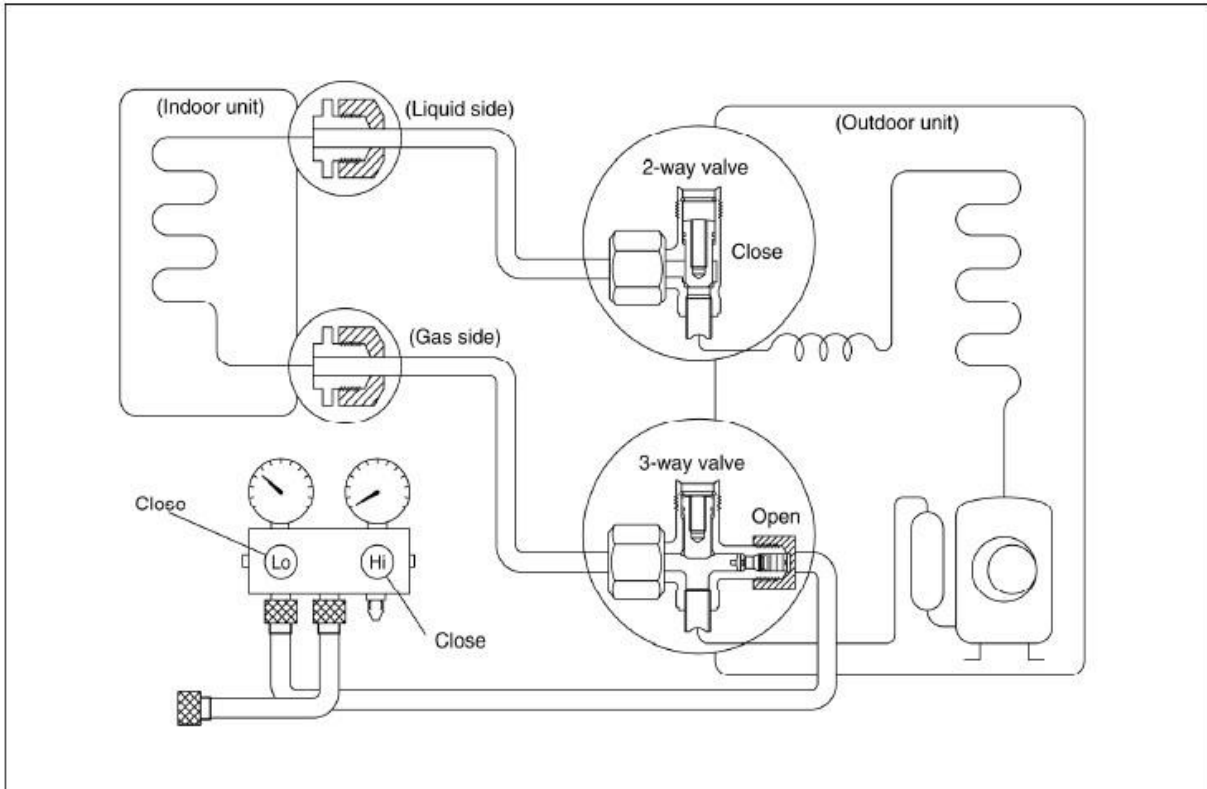

#### Procedure

- 1). Confirm that both the 2-way and 3-way valves are set to the opened position  
Remove the valve stem caps and confirm that the valve stems are in the opened position.  
Be sure to use a hexagonal wrench to operate the valve stems.
- 2). Connect the charge hose with the push pin of handle Lo to the 3-way valves gas service port.
- 3). Air purging of the charge hose.  
Open the handle Lo valve of the manifold valve slightly to purge air from the charge hose for 5 seconds and then close it quickly.
- 4). Set the 2-way valve to the close position.
- 5). Operate the air conditioner at the cooling cycle and stop it when the gauge indicates 0.1MPa.
- 6). Set the 3-way valve to the closed position immediately  
Do this quickly so that the gauge ends up indicating 0.3 to 0.5Mpa.  
Disconnect the charge set, and tighten the 2-way and 3-way valve's stem nuts.  
Use a torque wrench to tighten the 3-way valves service port cap to a torque of 1.8 kgf.m.  
Be sure to check for gas leakage.

## 16.7 Re-installation while the outdoor unit need to be repaired

### 1. Evacuation for the whole system

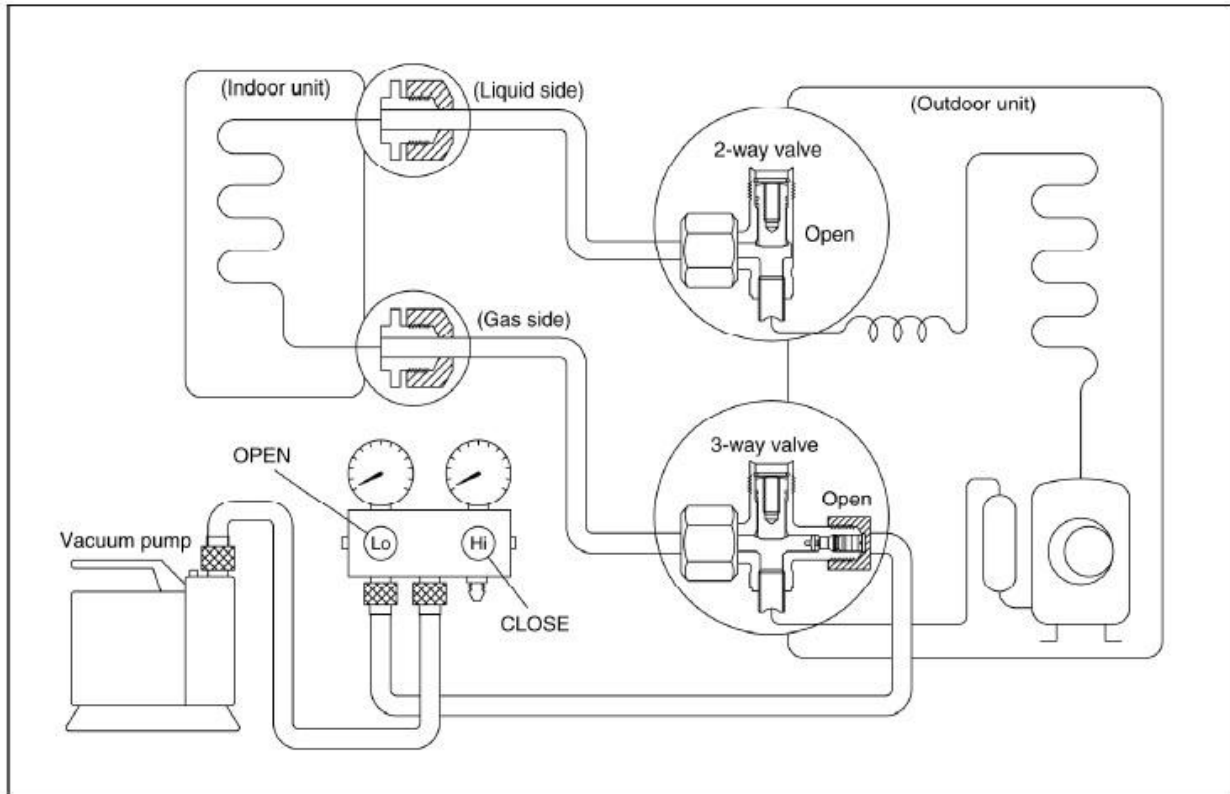

#### Procedure:

- 1). Confirm that both the 2-way and 3-way valves are set to the opened position.
- 2). Connect the vacuum pump to 3-way valve's service port.
- 3). Evacuation for approximately one hour. Confirm that the compound meter indicates  $-0.1\text{Mpa}$ .
- 4). Close the valve (Low side) on the charge set, turn off the vacuum pump, and confirm that the gauge needle does not move (approximately 5 minutes after turning off the vacuum pump).
- 5). Disconnect the charge hose from the vacuum pump.

## 2. Refrigerant charging

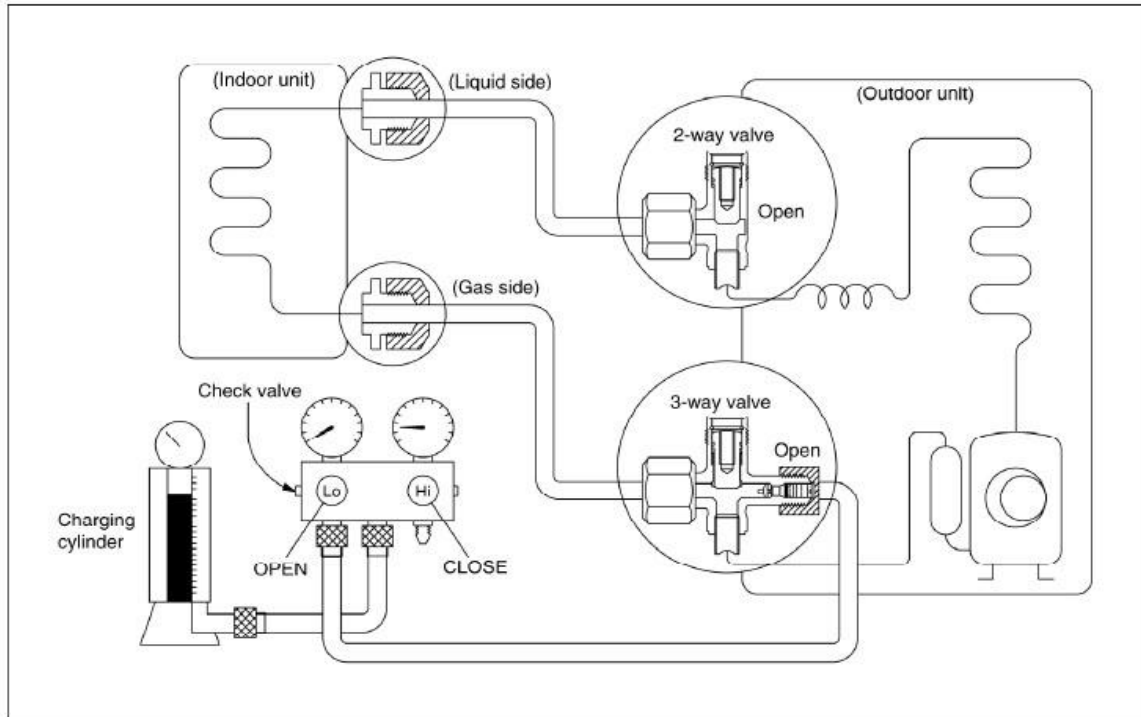

### Procedure:

- 1). Connect the charge hose to the charging cylinder, open the 2-way valve and the 3-way valve  
Connect the charge hose which you disconnected from the vacuum pump to the valve at the bottom of the cylinder. If the refrigerant is R410A, make the cylinder bottom up to ensure liquid charge.
- 2). Purge the air from the charge hose  
Open the valve at the bottom of the cylinder and press the check valve on the charge set to purge the air (be careful of the liquid refrigerant).
- 3) Put the charging cylinder onto the electronic scale and record the weight.
- 4). Open the valves (Low side) on the charge set and charge the system with liquid refrigerant  
If the system cannot be charge with the specified amount of refrigerant, or can be charged with a little at a time (approximately 150g each time) , operating the air conditioner in the cooling cycle; however, one time is not sufficient, wait approximately 1 minute and then repeat the procedure.
- 5).When the electronic scale displays the proper weight, disconnect the charge hose from the 3-way valve's service port immediately  
If the system has been charged with liquid refrigerant while operating the air conditioner, turn off the air conditioner before disconnecting the hose.
- 6). Mounted the valve stem caps and the service port  
Use torque wrench to tighten the service port cap to a torque of 18N.m.  
Be sure to check for gas leakage

---

## 17 Electronic control function

### 17.1 Abbreviation

T1: Indoor ambient temperature

T2: Coil temperature of indoor heat exchanger middle.

T2B: Coil temperature of indoor heat exchanger outlet(This sensor is located in outdoor unit)

T3: Coil temperature of outdoor heat exchanger

T4: Outdoor ambient temperature

T5: Compressor discharge temperature

Ts: Setting temperature

### 17.2 Electric control working environment.

15.2.1 Input voltage: 198V~264V.

15.2.2 Input power frequency:50Hz.

15.2.3 Indoor fan normal working amp. is less than 1A.

15.2.4 Outdoor fan. normal working amp. is less than 1.5A.

15.2.5 Four-way valve normal working amp. is less than 1A.

### 17.3 Outdoor unit's digital display tube

There is a digital display tube in outdoor PCB.

Digital display tube display function

- In standby , the LED displays “- -”
- In compressor operation, the LED display the running frequency,
- In defrosting mode, The LED displays “dF” or alternative displays between running frequency and “dF”(each displays 0.5s)
- In compressor pre-heating, The LED displays “PH” or alternative displays between running frequency and “PH”(each displays 0.5s)
- During the oil return process, The LED displays “RO” or alternative displays between running frequency and “RO”(each displays 0.5s)
- In low ambient cooling mode, the LED displays “LC” or alternative displays between running frequency and “LC”(each displays 0.5s)
- In forced cooling mode, the LED displays “FC” or alternative displays between running frequency and “FC”(each displays 0.5s)
- When PFC module protection occurs three times within 15 minutes, the LED displays “E6” or alternative displays between running frequency and “E6”(each displays 0.5s)
- In protection or malfunction, the LED displays error code or protection code.

## 17.4 Outdoor unit point check function

A check switch is included on the outdoor PCB.

Push SW1 to check the unit's status while running. The digital display shows the following codes each time the SW1 is pushed.

Number of Presses	Display	Remark										
0	Normal display	Displays running frequency, running state, or malfunction code										
1	Quantity of indoor units with working connection	Actual data <table border="1" style="margin-left: 20px;"> <thead> <tr> <th>Display</th> <th>Number of indoor unit</th> </tr> </thead> <tbody> <tr> <td>1</td> <td>1</td> </tr> <tr> <td>2</td> <td>2</td> </tr> <tr> <td>3</td> <td>3</td> </tr> <tr> <td>4</td> <td>4</td> </tr> </tbody> </table>	Display	Number of indoor unit	1	1	2	2	3	3	4	4
Display	Number of indoor unit											
1	1											
2	2											
3	3											
4	4											
2	Outdoor unit running mode code	Off: 0, Fan only: 1, Cooling: 2, Heating: 3, Forced cooling: 4. Forced defrosting :A										
3	Indoor unit A capacity	The capacity unit is horse power. If the indoor unit is not connected, the digital display shows the following: "____" (9K:1HP,12K:1.2HP,18K:1.5HP)										
4	Indoor unit B capacity											
5	Indoor unit C capacity											
6	Indoor unit D capacity											
7	Indoor unit E capacity											
8	Indoor unit A capacity demand code	Norm code*HP (9K: 1HP,12K: 1.2HP,18K: 1.5HP)										
9	Indoor unit B capacity demand code											
10	Indoor unit C capacity demand code											
11	Indoor unit D capacity demand code											
12	Indoor unit E capacity demand code											
13	Outdoor unit amendatory capacity demand code											
14	The frequency corresponding to the total indoor units' amendatory capacity demand											
15	The frequency after the frequency limit											
16	The frequency sending to compressor control chip											
17	Indoor unit A evaporator outlet temperature (T <sub>2B</sub> A)	If the temperature is lower than -9 °C, the digital display shows "-9." If the temperature is higher than 70 °C, the digital display shows "70." If the indoor unit is not connected, the digital display shows: "____"										
18	Indoor unit B evaporator outlet temperature (T <sub>2B</sub> B)											
19	Indoor unit C evaporator outlet temperature (T <sub>2B</sub> C)											
20	Indoor unit D evaporator outlet temperature (T <sub>2B</sub> D)											
21	Indoor unit E evaporator outlet temperature (T <sub>2B</sub> E)											
22	Indoor unit A room temperature (T <sub>1</sub> A)	If the temperature is lower than 0 °C, the digital display shows "0." If the temperature is higher than 50 °C, the digital display shows "50." If the indoor unit is not connected, the digital display shows: "____"										
23	Indoor unit B room temperature (T <sub>1</sub> B)											
24	Indoor unit C room temperature (T <sub>1</sub> C)											
25	Indoor unit D room temperature (T <sub>1</sub> D)											
26	Indoor unit E room temperature (T <sub>1</sub> E)											
27	Indoor unit A evaporator temperature (T <sub>2</sub> A)	If the temperature is lower than -9 °C, the digital display shows "-9." If the temperature is higher than 70 °C, the digital display shows "70." If the indoor unit is not connected, the digital display shows: "____"										
28	Indoor unit B evaporator temperature (T <sub>2</sub> B)											
29	Indoor unit C evaporator temperature (T <sub>2</sub> C)											
30	Indoor unit D evaporator temperature (T <sub>2</sub> D)											
31	Indoor unit E evaporator temperature (T <sub>2</sub> E)											

32	Condenser pipe temperature (T3)			
33	Outdoor ambient temperature (T4)			
34	Compressor discharge temperature (TP)	The display value is between 30–129 °C. If the temperature is lower than 30 °C, the digital display shows “30.” If the temperature is higher than 99 °C, the digital display shows single and double digits. For example, if the digital display shows “0.5”, the compressor discharge temperature is 105 °C.		
35	AD value of current	The display value is a hex number.		
36	AD value of voltage	For example, the digital display tube shows “Cd”, it means AD value is 205.		
37	EXV open angle for A indoor unit	Actual data/4. If the value is higher than 99, the digital display shows single and double digits. For example, if the digital display shows “2.0”, the EXV open angle is 120x4=480p.		
38	EXV open angle for B indoor unit			
39	EXV open angle for C indoor unit			
40	EXV open angle for D indoor unit			
41	EXV open angle for E indoor unit			
42	Frequency limit symbol	Bit7	Frequency limit caused by IGBT radiator	The display value is a hexadecimal number. For example, the digital display show 2A, then Bit5=1, Bit3=1, and Bit1=1. This means that a frequency limit may be caused by T4, T3, or the current.
		Bit6	Frequency limit caused by PFC	
		Bit5	Frequency limit caused by T4.	
		Bit4	Frequency limit caused by T2.	
		Bit3	Frequency limit caused by T3.	
		Bit2	Frequency limit caused by T5.	
		Bit1	Frequency limit caused by current	
Bit0	Frequency limit caused by voltage			
43	Average value of T2	(Sum T2 value of all indoor units)/(number of indoor units in good connection)		
44	Outdoor unit fan motor state	Off: 0, High speed:1, Med speed: 2, Low speed: 3, Breeze:4, Super breeze: 5		
45	The last error or protection code	00 means no malfunction and protection		
46	F indoor unit capacity			
47	F indoor unit capacity demand code			
48	F indoor unit evaporator outlet temperature (T <sub>2B</sub> F)	If the temperature is lower than -9 °C, the digital display shows “-9.” If the temperature is higher than 70 °C, the digital display shows “70.” If the indoor unit is not connected, the digital display shows: “——”		
49	F indoor unit room temperature (T <sub>1</sub> F)			
50	F indoor unit evaporator temperature (T <sub>2</sub> F)			
51	EXV open angle for F indoor unit			

## 17.5 Protection

### 17.5.1 Three minutes delay at restart for compressor.

### 17.5.2 Temperature protection of compressor discharge.

When the compressor discharge temp. is getting higher, the running frequency will be limited as below rules:

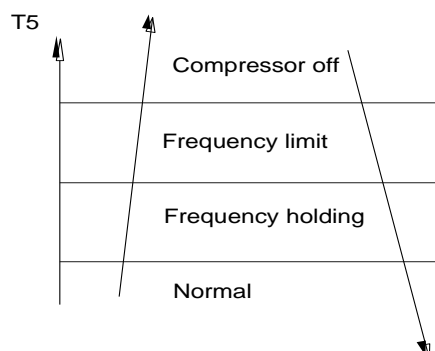



### 17.5.3 Low voltage protection

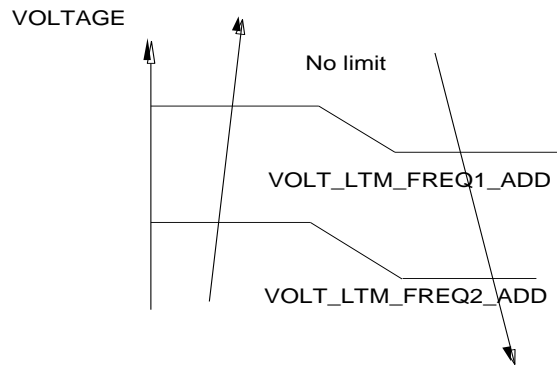

Note: if the low voltage protection occurs and not resumes within 3min, it will keep the protection always after restart the machine.

### 17.5.4 Compressor current limit protection

Temperature interval of current limit is same as range of T4 limited frequency.

**Cooling mode:**

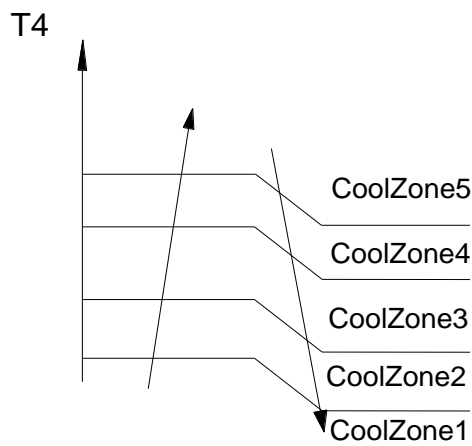

**Heating mode:**

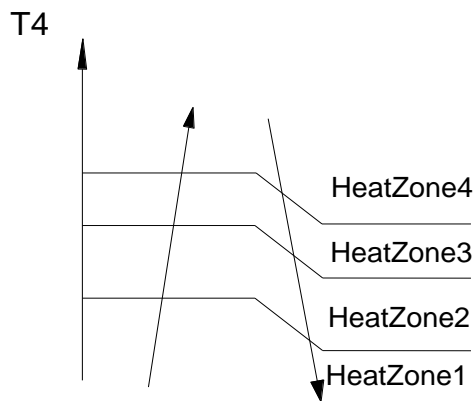

### 17.5.5 Indoor / outdoor units communication protection

If the indoor units cannot receive the feedback signal from the outdoor units for 2 minutes, the AC will stop and display the failure.

---

### 17.5.6 High condenser coil temp. protection.

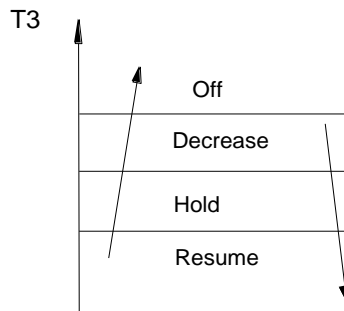

### 17.5.7 Outdoor unit anti-freezing protection

When  $T_2 < 4^\circ\text{C}$  for 250 seconds or  $T_2 < 0^\circ\text{C}$ , the indoor unit capacity demand will be zero and resume to normal when  $T_2 > 8^\circ\text{C}$  and the time of protection is no less than 3 minutes.

### 17.5.8 Oil return

#### Running rules:

1. If the compressor frequency keeps lower than setting frequency for setting time, the AC will rise the frequency to setting frequency for setting time and then resume to former frequency.
  2. The EXV will keep 300p while the indoor units will keep the current running mode.
- If the outdoor ambient is higher than setting frequency during the oil return, the AC quit oil return.

### 17.5.9 Low outdoor ambient temperature protection

When compressor is off,  $T_4$  is be lower than  $-35^\circ\text{C}$ .for 10s, the AC will stop and display "LP".

When compressor is on,  $T_4$  is be lower than  $-40^\circ\text{C}$ .for 10s, the AC will stop and display "LP".

When  $T_4$  is no lower than  $-32^\circ\text{C}$ .for 10s, the unit will exit protection.

## 18 Troubleshooting

### 18.1 Indoor unit error code explanation:

For 15C/AB/Cassette

Malfunction	Error Code	Timer Lamp	Operation Lamp (flashes)
Indoor EEPROM malfunction	E0	X	1
Communication malfunction between indoor and outdoor units	E1	X	2
Indoor fan speed has been out of control	E3	X	4
Open or short circuit of T1 temperature sensor	E4	X	5
Open or short circuit of T2 temperature sensor	E5	X	6
Water level alarm	EE	X	8
Overcurrent protection (For some units)	F0	O	1
Open or short circuit of T4 temperature sensor	F1	O	2
Open or short circuit of T3 temperature sensor	F2	O	3
Open or short circuit of T5 temperature sensor	F3	O	4
Outdoor EEPROM malfunction (For some units)	F4	O	5
Outdoor fan speed is out of control	F5	O	6
Open or short circuit of T2B temperature sensor	F6	O	7
IPM module malfunction	P0	☆	1
Over voltage or over low voltage protection	P1	☆	2
Too low ambient temperature protection	P3	☆	4
Inverter compressor drive protection	P4	☆	5
Mode conflict	--	☆	6
Low pressure protection of compressor	P6	☆	7
<b>O (on) X(off) ☆(flash at 2Hz)</b>			

For Console

Malfunction	Timer Lamp	Operation Lamp (flashes)
Indoor EEPROM malfunction	X	1
Communication malfunction between indoor and outdoor units	X	2
Indoor fan speed has been out of control	X	4
Open or short circuit of T1 temperature sensor	X	5
Open or short circuit of T2 temperature sensor	X	6
Overcurrent protection (For some units)	O	1
Open or short circuit of T4 temperature sensor	O	2
Open or short circuit of T3 temperature sensor	O	3
Open or short circuit of T5 temperature sensor	O	4
Outdoor EEPROM malfunction (For some units)	O	5
Outdoor fan speed is out of control	O	6
Open or short circuit of T2B temperature sensor (For free-match indoor units)	O	7
IPM module malfunction	☆	1

Over voltage or over low voltage protection	☆	2
Too low ambient temperature protection	☆	4
Inverter compressor drive protection	☆	5
Mode conflict	☆	6
Low pressure protection of compressor	☆	7
<b>O (on) X(off) ☆(flash at 2Hz)</b>		

For other type

Malfunction	Error Code	Timer Lamp	Operation Lamp (flashes)
Indoor EEPROM malfunction	E0	X	1
Communication malfunction between indoor and outdoor units	E1	X	2
Indoor fan speed has been out of control	E3	X	4
Open or short circuit of T1 temperature sensor	E4	X	5
Open or short circuit of T2 temperature sensor	E5	X	6
Water level alarm	EE	X	8
Overcurrent protection (For some units)	F0	O	1
Open or short circuit of T4 temperature sensor	F1	O	2
Open or short circuit of T3 temperature sensor	F2	O	3
Open or short circuit of T5 temperature sensor	F3	O	4
Outdoor EEPROM malfunction (For some units)	F4	O	5
Outdoor fan speed is out of control	F5	O	6
Open or short circuit of T2B temperature sensor (For free-match indoor units)	F6	O	7
Communication error between auto-lifting panel and slim cassette (For slim cassette with auto-lifting panel)	F7	O	8
Auto-lifting panel is faulty (For slim cassette with auto-lifting panel)	F8	O	9
Auto-lifting panel is not closed (For slim cassette with auto-lifting panel)	F9	O	10
IPM module malfunction	P0	☆	1
Over voltage or over low voltage protection	P1	☆	2
Too low ambient temperature protection	P3	☆	4
Error rotor position protection of compressor	P4	☆	5
Mode conflict	P5	☆	6
Low pressure protection of compressor	P6	☆	7
<b>O (on) X(off) ☆(flash at 2Hz)</b>			

## 18.2 Outdoor unit error code explanation:

Display	LED STATUS
E0	Outdoor EEPROM malfunction
E2	Indoor / outdoor units communication error
E3	Communication malfunction between IPM board and outdoor main board
E4	Open or short circuit of outdoor unit temperature sensor(T3,T4.T5)
E5	Voltage protection
E6	PFC module protection
E8	Outdoor fan speed has been out of control
F1	No A Indoor unit coil outlet temperature sensor or connector of sensor is defective
F2	No B Indoor unit coil outlet temperature sensor or connector of sensor is defective
F3	No C Indoor unit coil outlet temperature sensor or connector of sensor is defective
F4	No D Indoor unit coil outlet temperature sensor or connector of sensor is defective
F5	No E Indoor unit coil outlet temperature sensor or connector of sensor is defective
P1	High pressure protection (For M4OB-36HFN8-Q, M5OD-42HFN8-Q)
P2	Low pressure protection (For M4OB-36HFN8-Q, M5OD-42HFN8-Q)
P3	Current protection of compressor
P4	Temperature protection of compressor discharge
P5	High temperature protection of condenser
P6	IPM module protection
LP	Low ambient temperature protection

Note: Once these error codes display, they will disappear in at least 30 seconds if the unit come back to normal.(Except E2&E3)

---

## 18.3 Troubleshooting

18.3.1 For the indoor unit

### 18.3.1.1 Indoor EEPROM malfunction

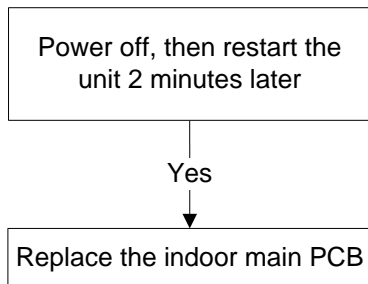

EEPROM: An electrically erasable programmable read-only memory whose contents can be erased and reprogrammed using a pulsed voltage.

### 18.3.1.2 Indoor / outdoor units communication error

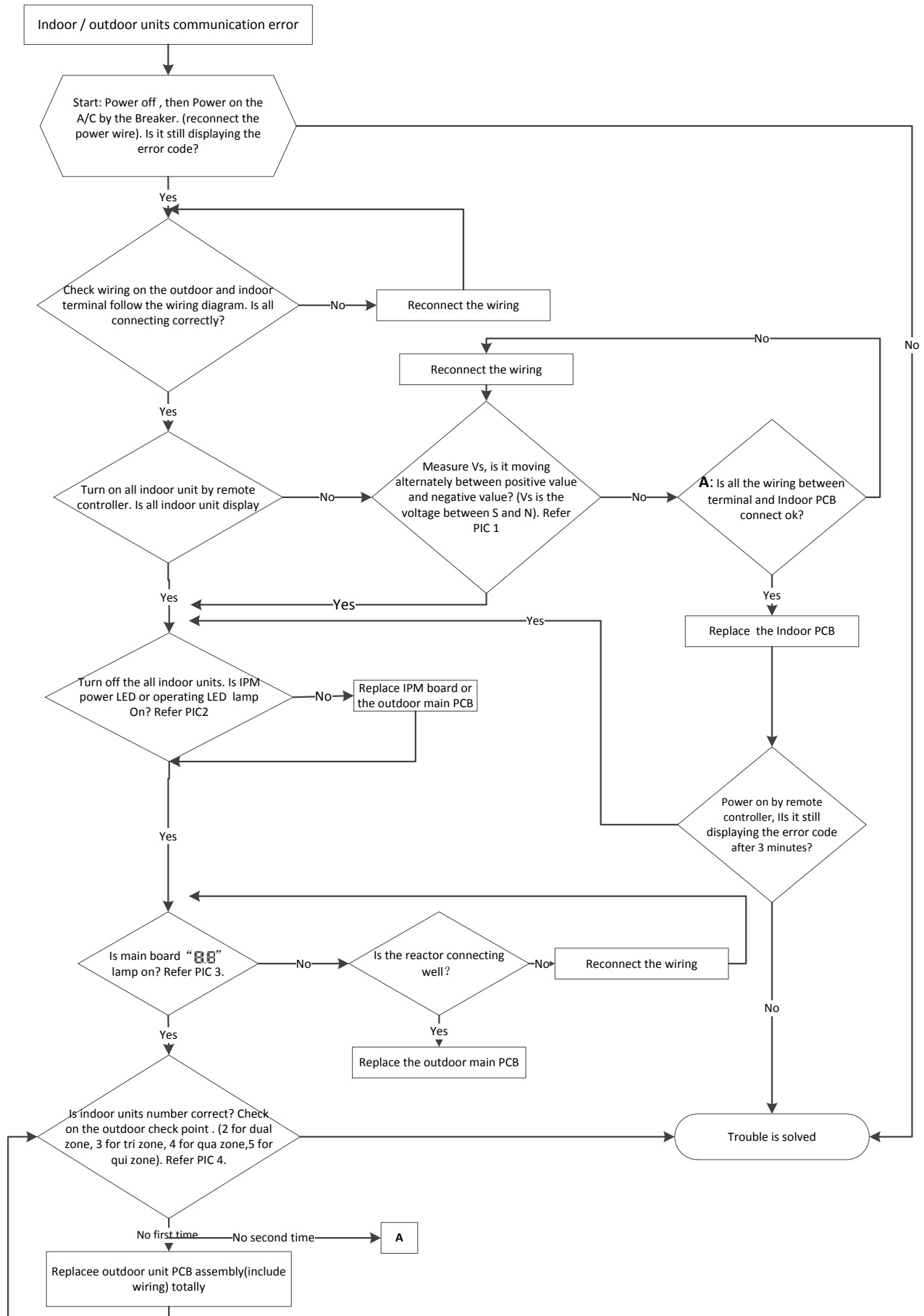



Pic 1: check the voltage of N to S (Vs), is it moving alternately between positive value and negative value?

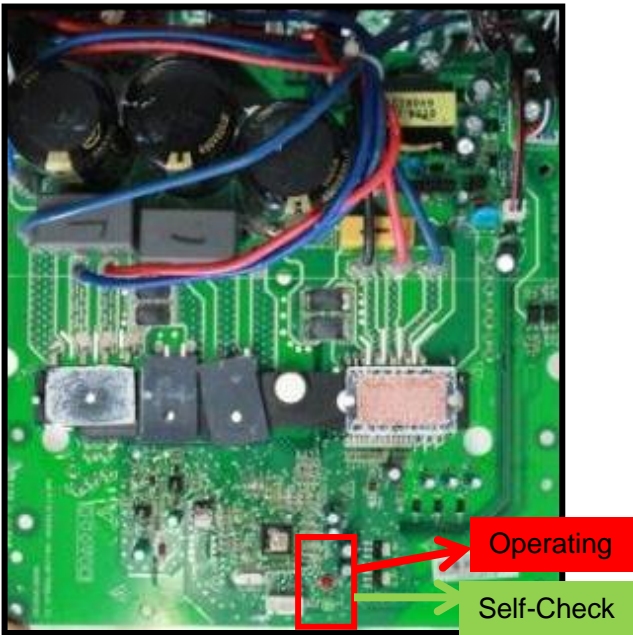

Pic 2: IPM or outdoor main PCB

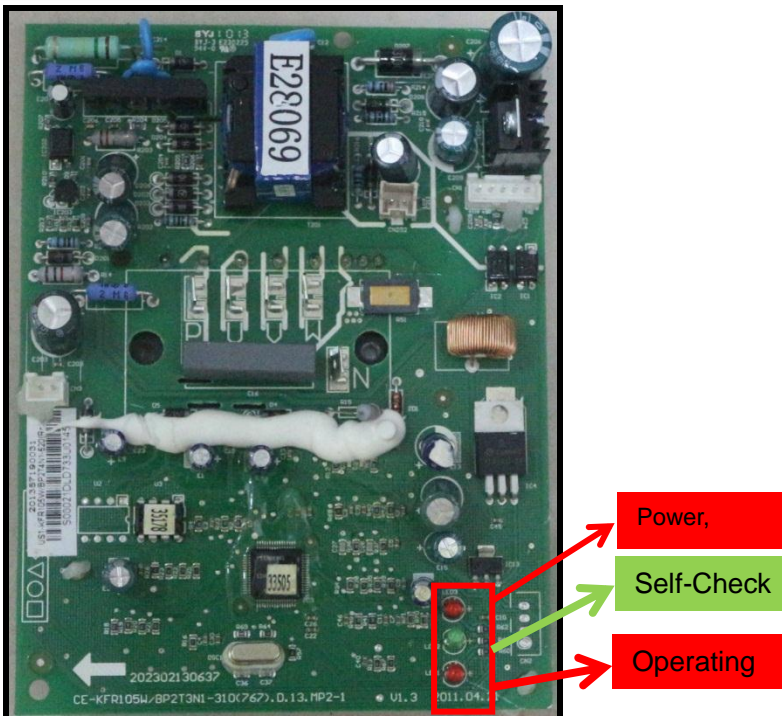

Pic 2: IPM or outdoor main PCB



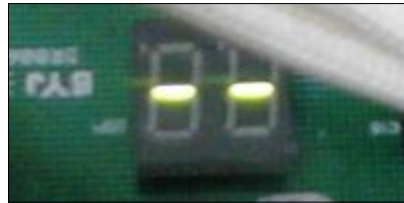

PIC3 : Main board LED when power on and unit standby.



PIC 4: check point button,  
Press 1 time for check how many indoor units are connected

### 18.3.1.3 indoor unit fan speed has been out of control

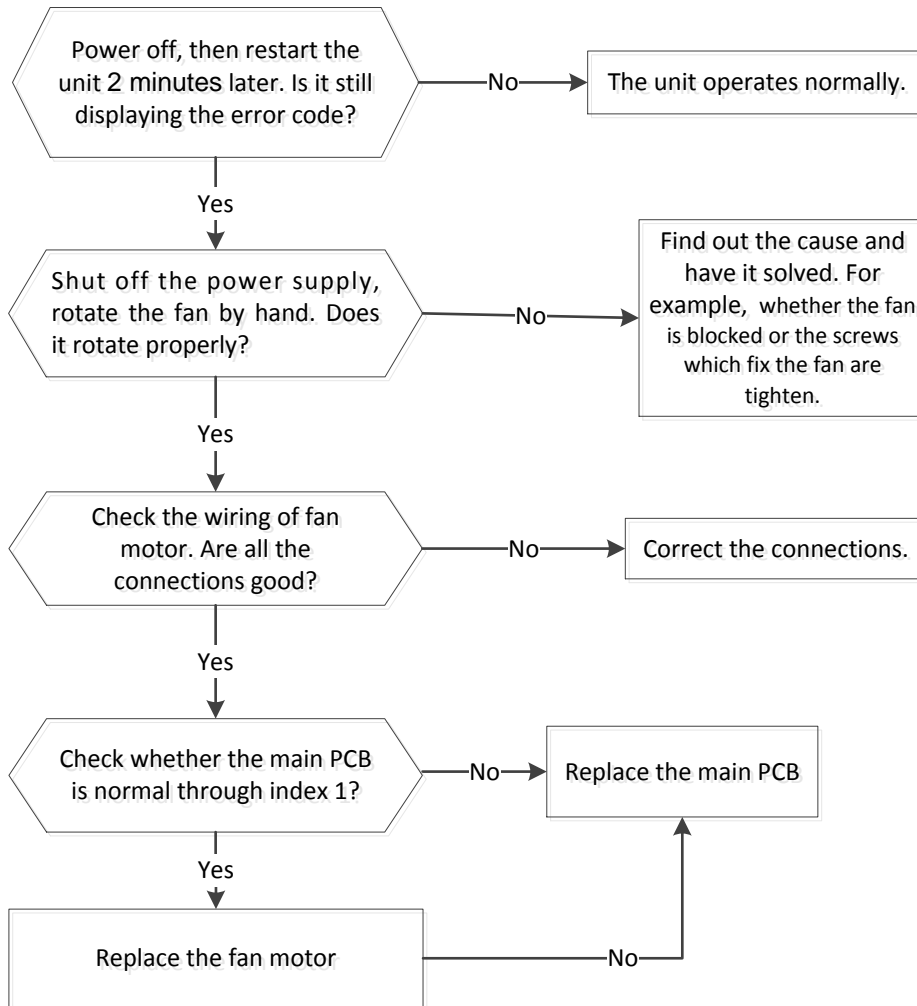

Index 1:

#### 1: Indoor AC fan motor

Power on and set the unit running in fan mode at high fan speed. After running for 15 seconds, measure the voltage of pin1 and pin2. If the value of the voltage is less than 100V(208~240V power supply) or 50V(115V power supply), the PCB must have problems and need to be replaced.

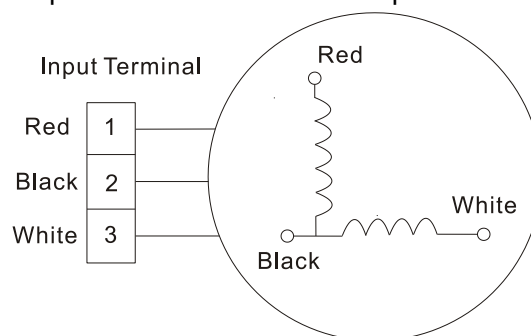

#### 2. Indoor DC fan motor(control chip is inside fan motor)

Power on and when the unit is in standby, measure the voltage of pin1-pin3, pin4-pin3 in fan motor connector. If the value of the voltage is not in the range showing in below table, the PCB must have problems and need to be replaced.

For other models:

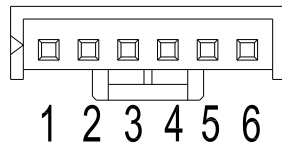
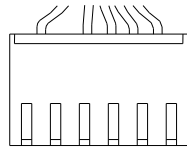

For console:

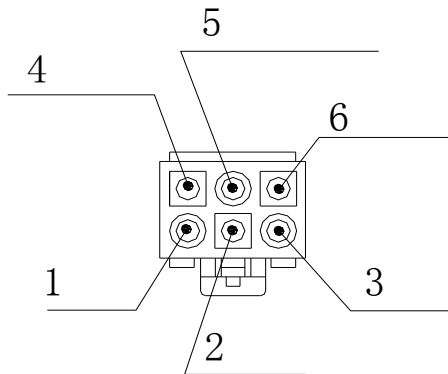

DC motor voltage input and output

For split type:

NO.	Color	Signal	Voltage
1	Red	Vs/Vm	280V~380V
2	---	---	---
3	Black	GND	0V
4	White	Vcc	14-17.5V
5	Yellow	Vsp	0~5.6V
6	Blue	FG	14-17.5V

For other types:

NO.	Color	Signal	Voltage
1	Red	Vs/Vm	192V~380V
2	---	---	---
3	Black	GND	0V
4	White	Vcc	13.5-16.5V
5	Yellow	Vsp	0~6.5V
6	Blue	FG	13.5-16.5V

### 18.3.1.4 Open or short circuit of temperature sensor.

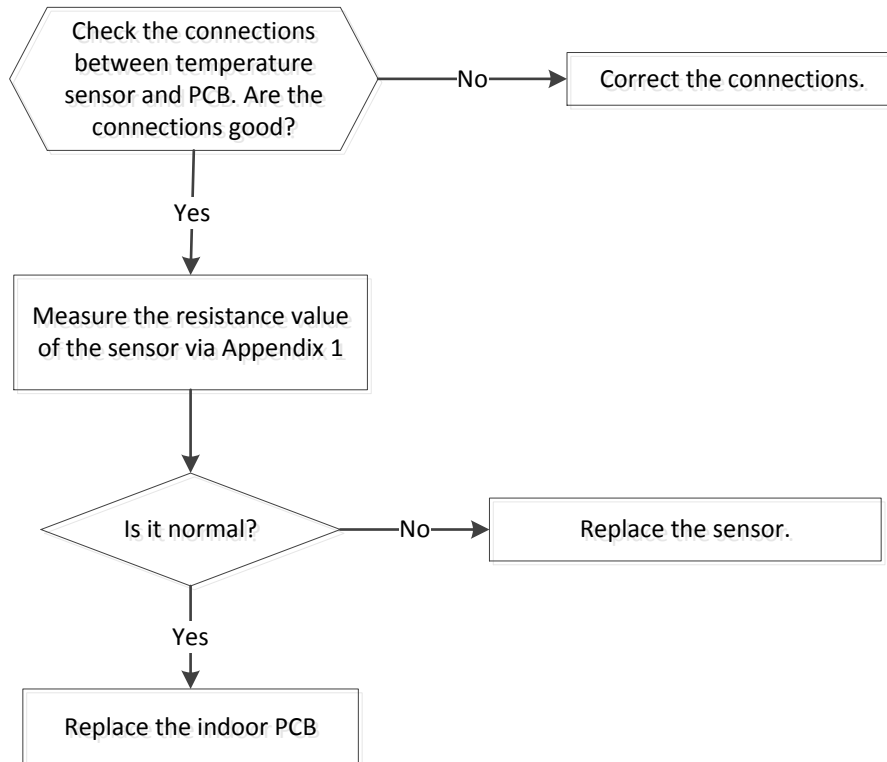

### 18.3.1.5 Full-water malfunction

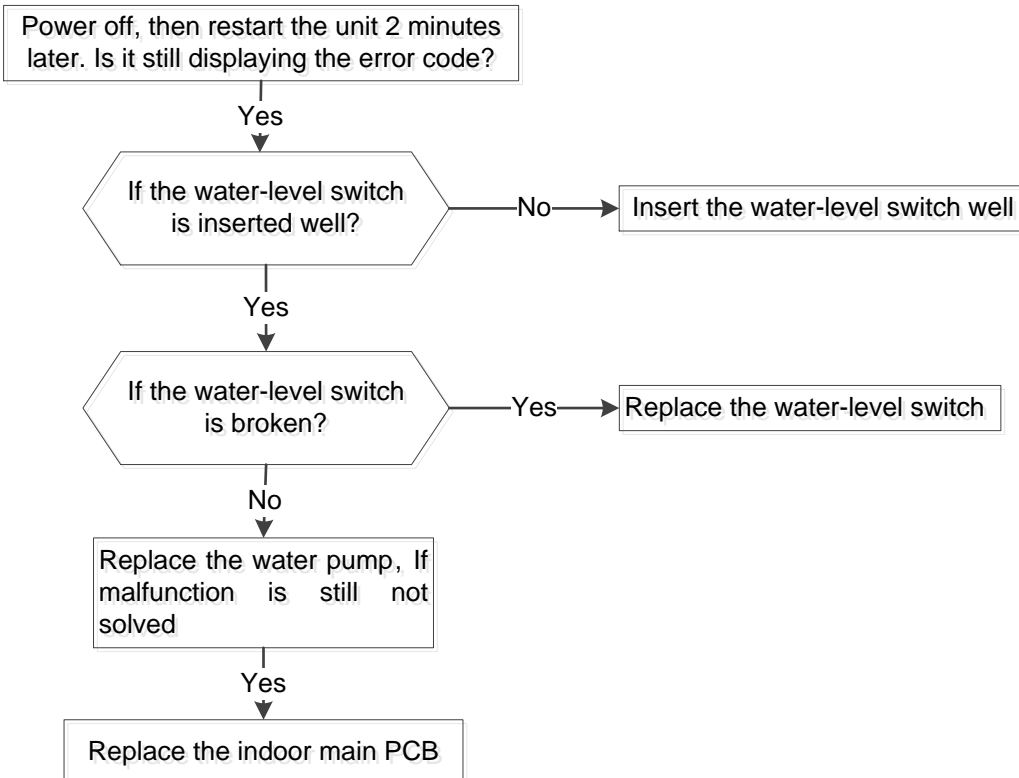

---

## 18.3.2 For the outdoor unit

### 18.3.2.1 Outdoor EEPROM malfunction(ODU E0)

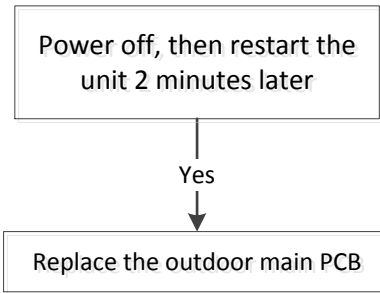

EEPROM: An electrically erasable programmable read-only memory whose contents can be erased and reprogrammed using a pulsed voltage.

### 18.3.2.2 Communication malfunction between IPM board and outdoor main board(ODU E3)

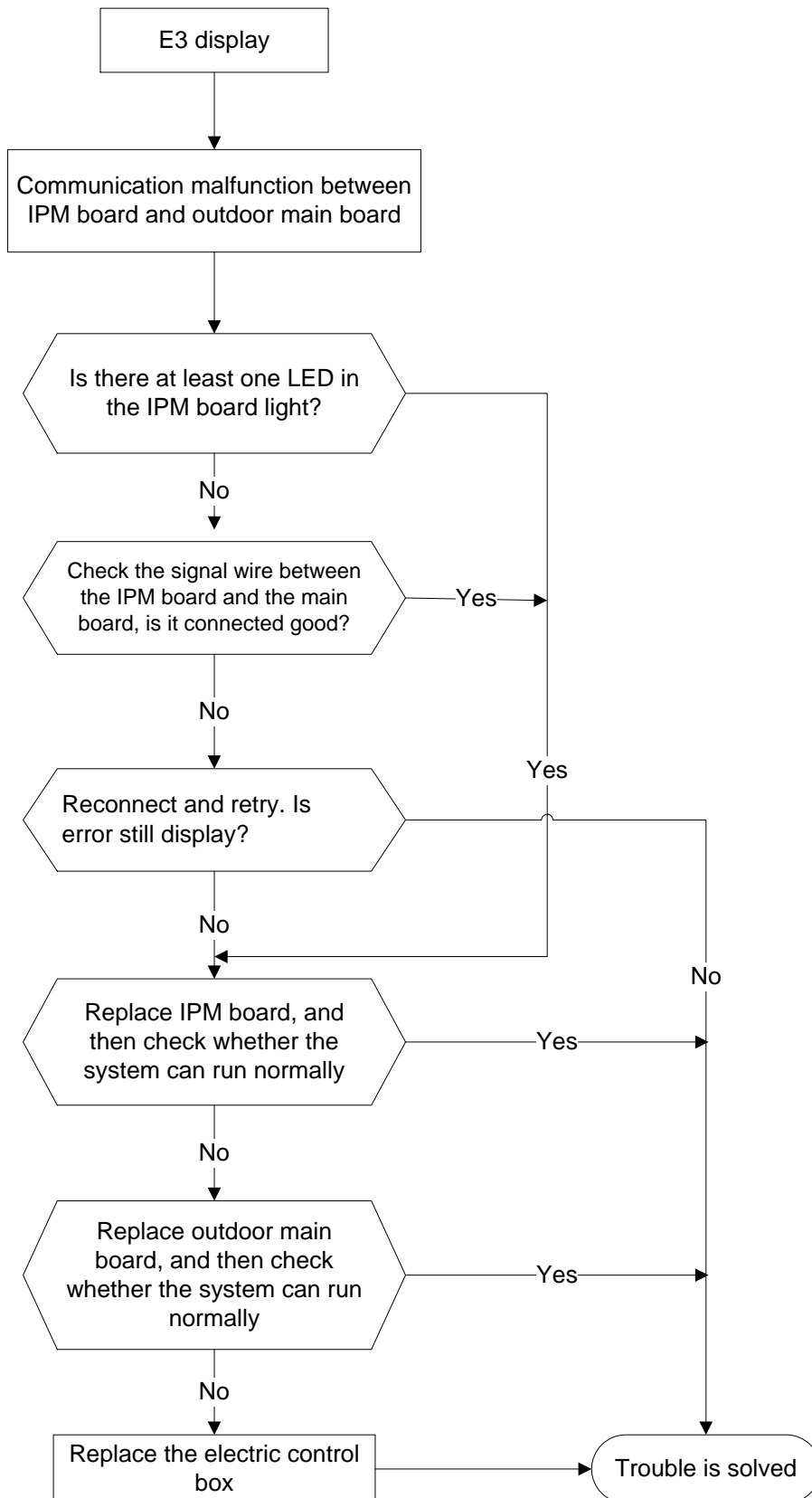

### 18.3.2.3 Voltage protection(ODU E5)

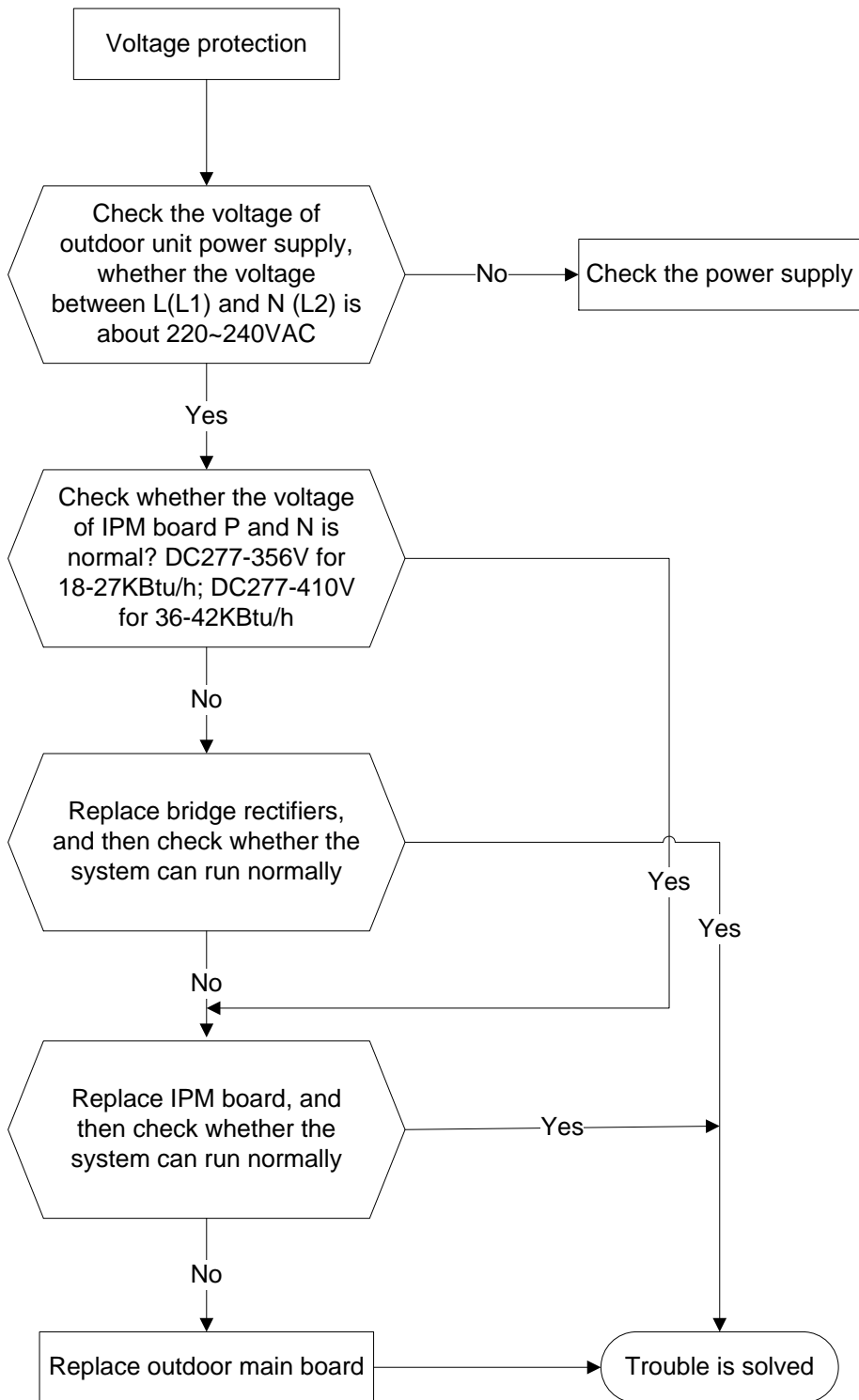

### 18.3.2.4 Outdoor unit fan speed has been out of control (E8)

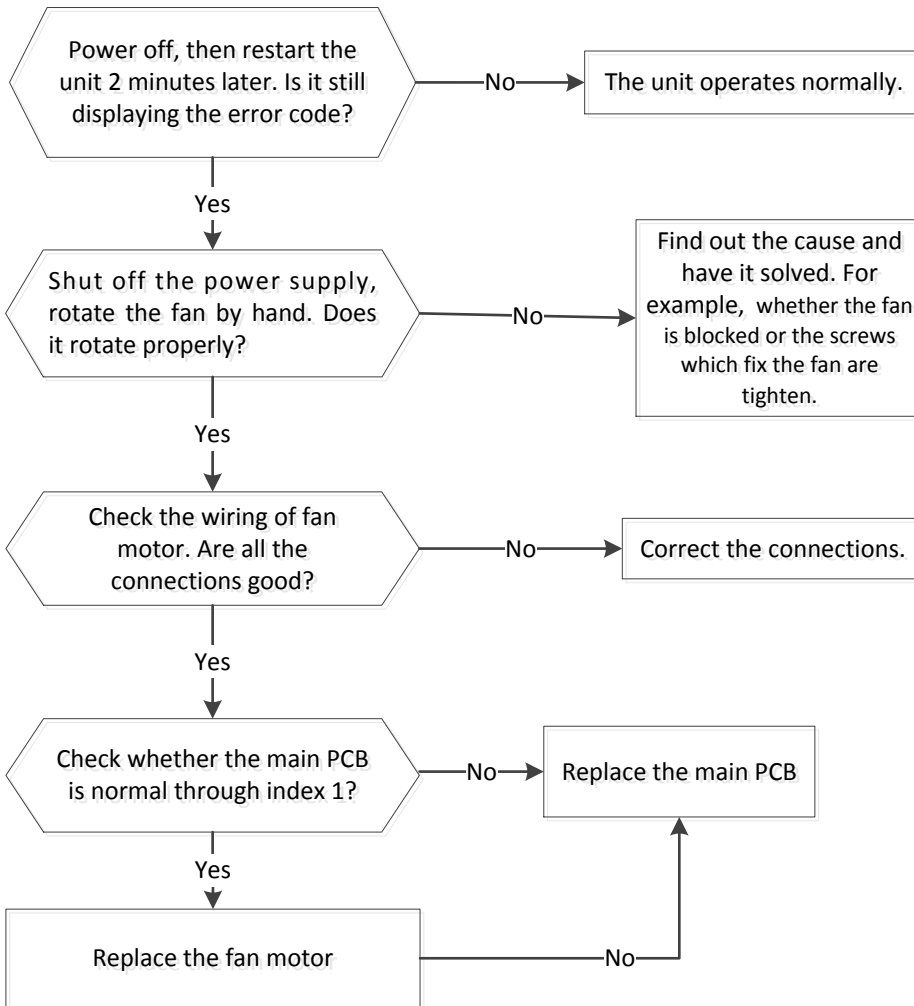

Index 1:

1. Outdoor DC fan motor(control chip is inside fan motor)

Power on and when the unit is in standby, measure the voltage of pin1-pin3, pin4-pin3 in fan motor connector. If the value of the voltage is not in the range showing in below table, the PCB must have problems and need to be replaced.

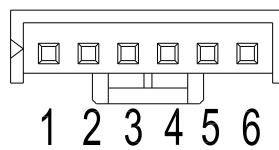

DC motor voltage input and output

NO.	Color	Signal	Voltage
1	Red	Vs/Vm	140V~380V
2	---	---	---
3	Black	GND	0V
4	White	Vcc	13.5-16.5V
5	Yellow	Vsp	0~6.5V
6	Blue	FG	15V



### 18.3.2.5 High pressure protection (ODU P1)(For 38QUS036DS4\*, 38QUS042DS5\*)

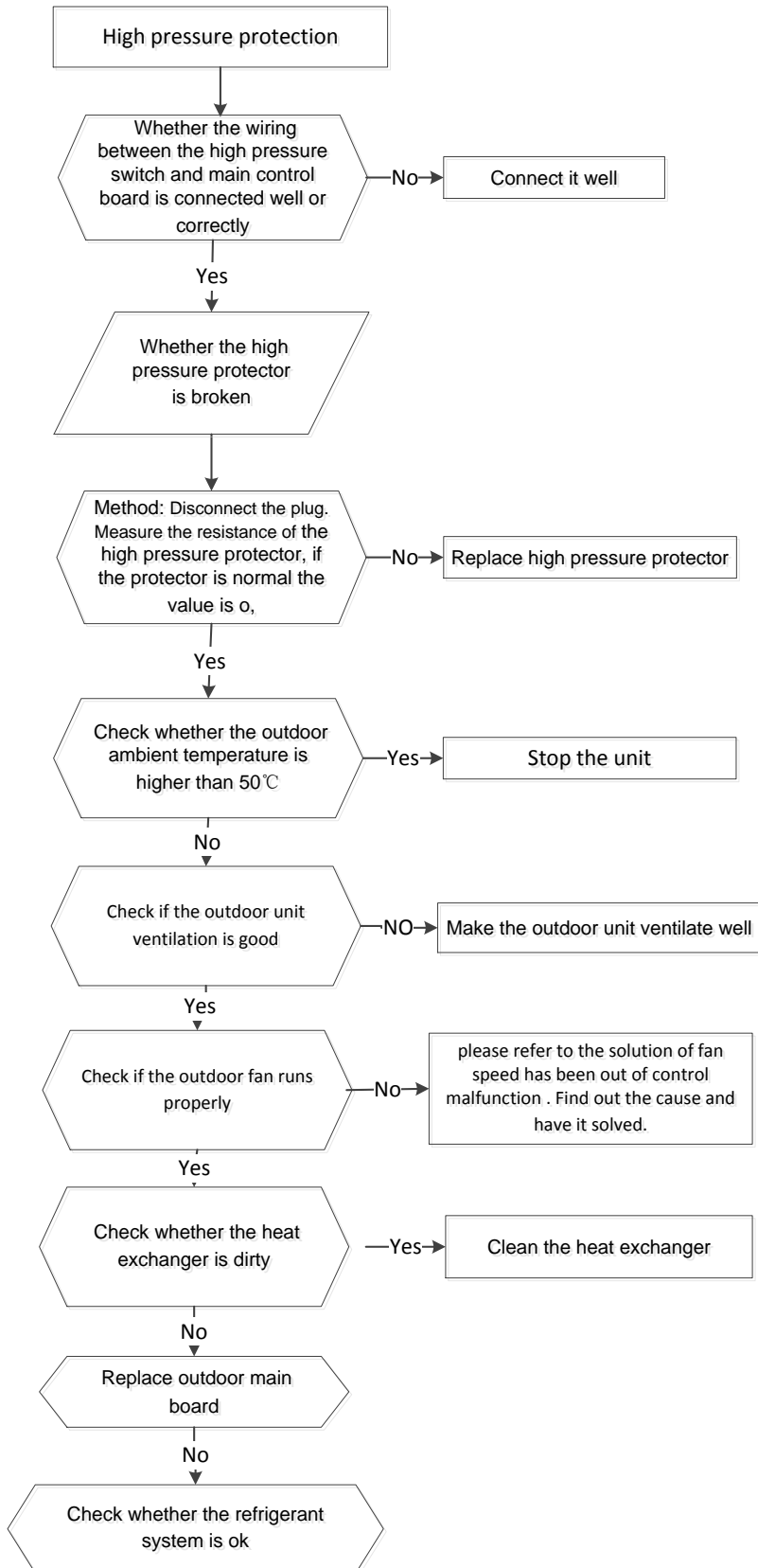

### 18.3.2.6 Low pressure protection (ODU P2)(For38QUS036DS4\*, 38QUS042DS5\*)

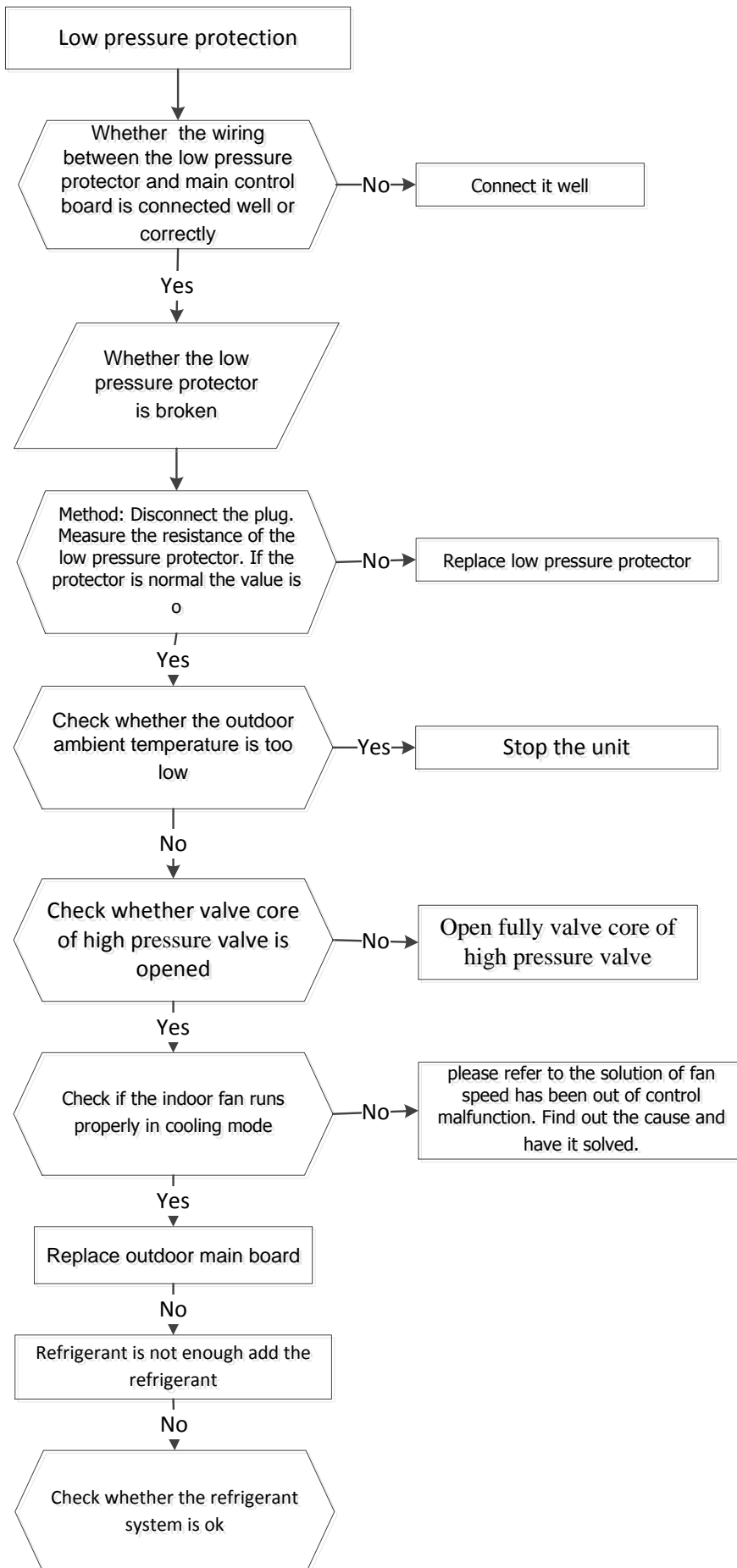

### 18.3.2.7 Current protection of compressor (ODU P3)

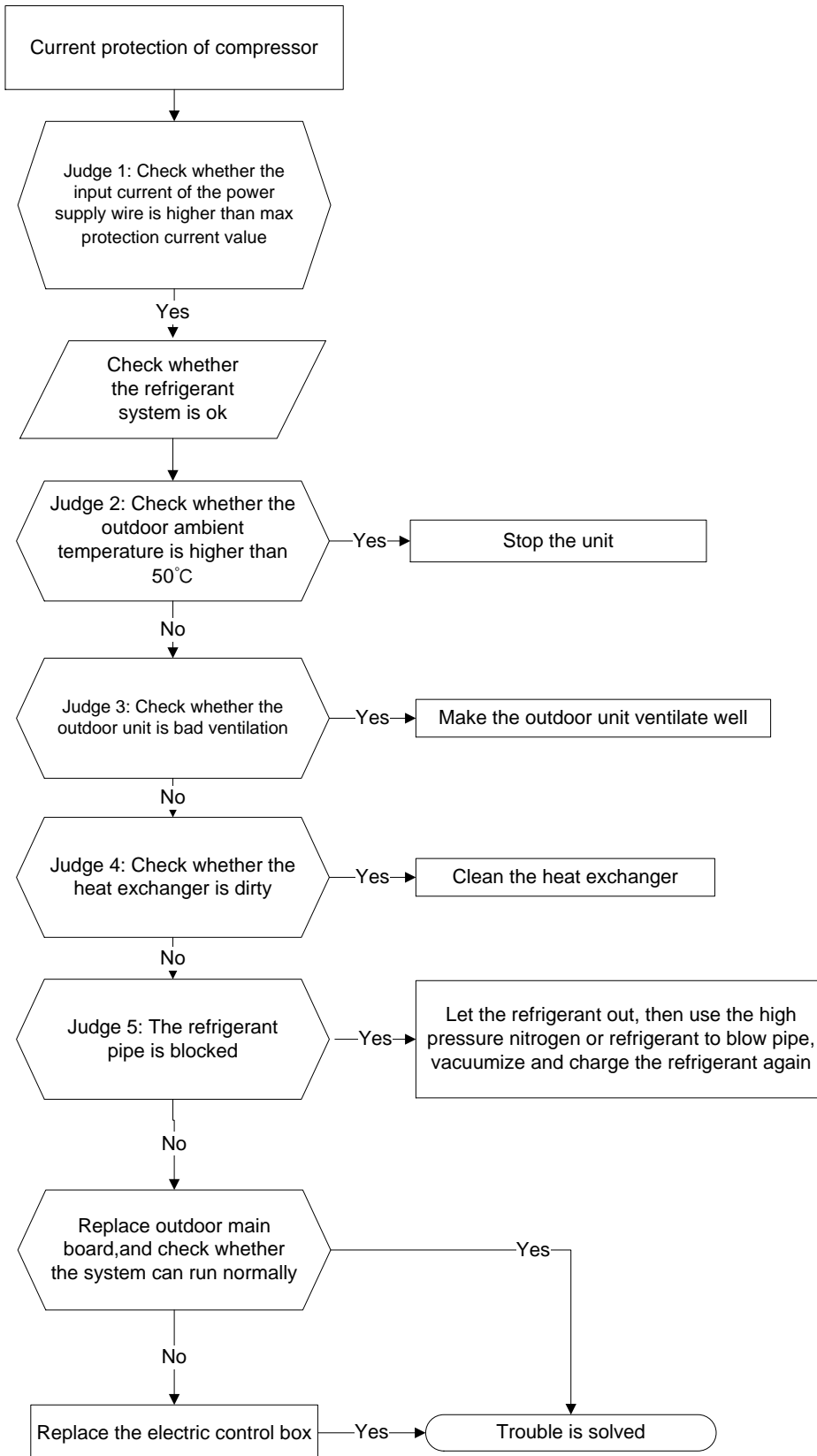

### 18.3.2.8 Temperature protection of compressor discharge (ODU P4)

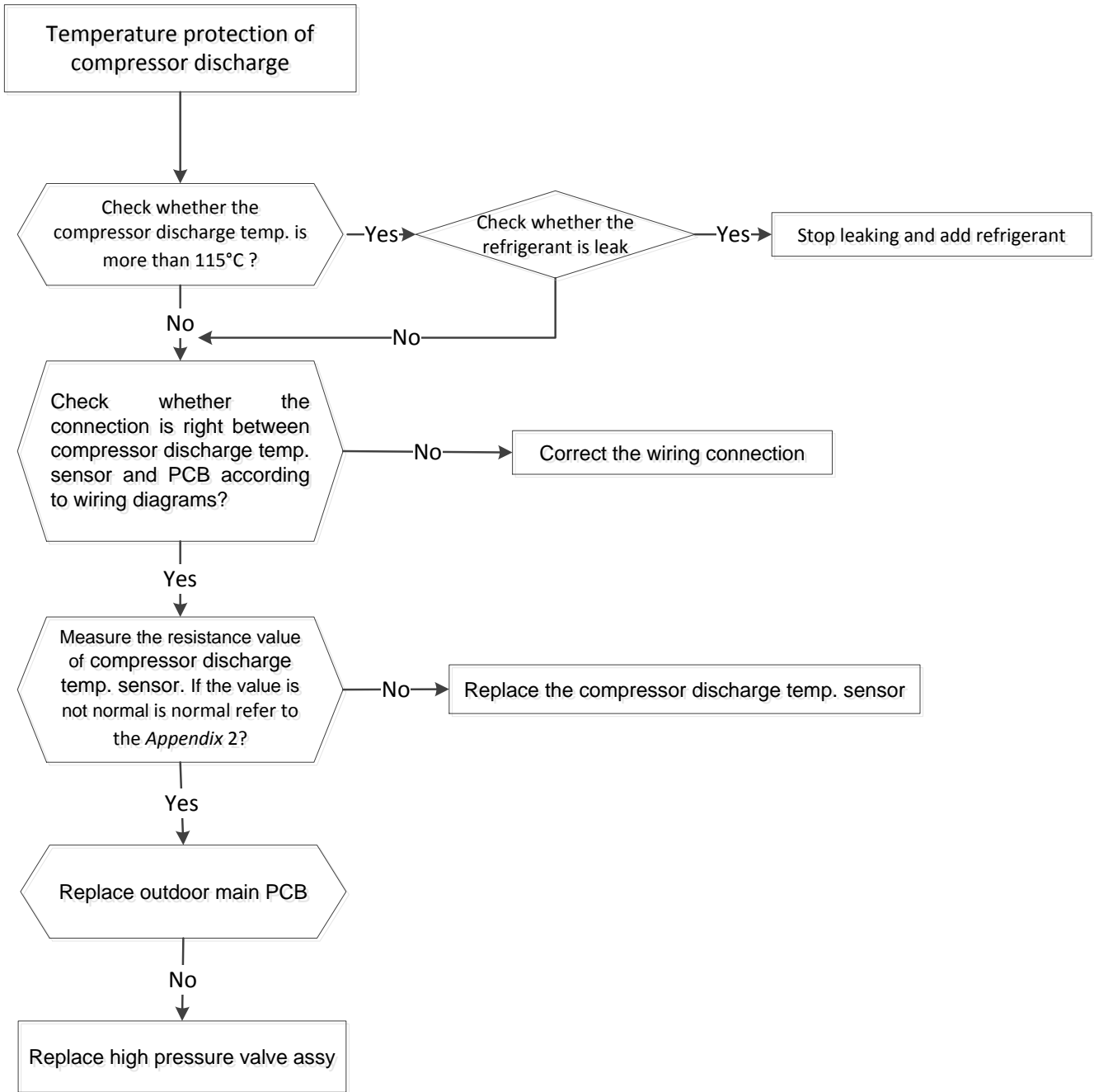

### 18.3.2.9 High temperature protection of condenser (ODU P5)

When outdoor pipe temperature is more than 65°C, the unit will stop, and unit runs again when outdoor pipe temperature less than 52°C.

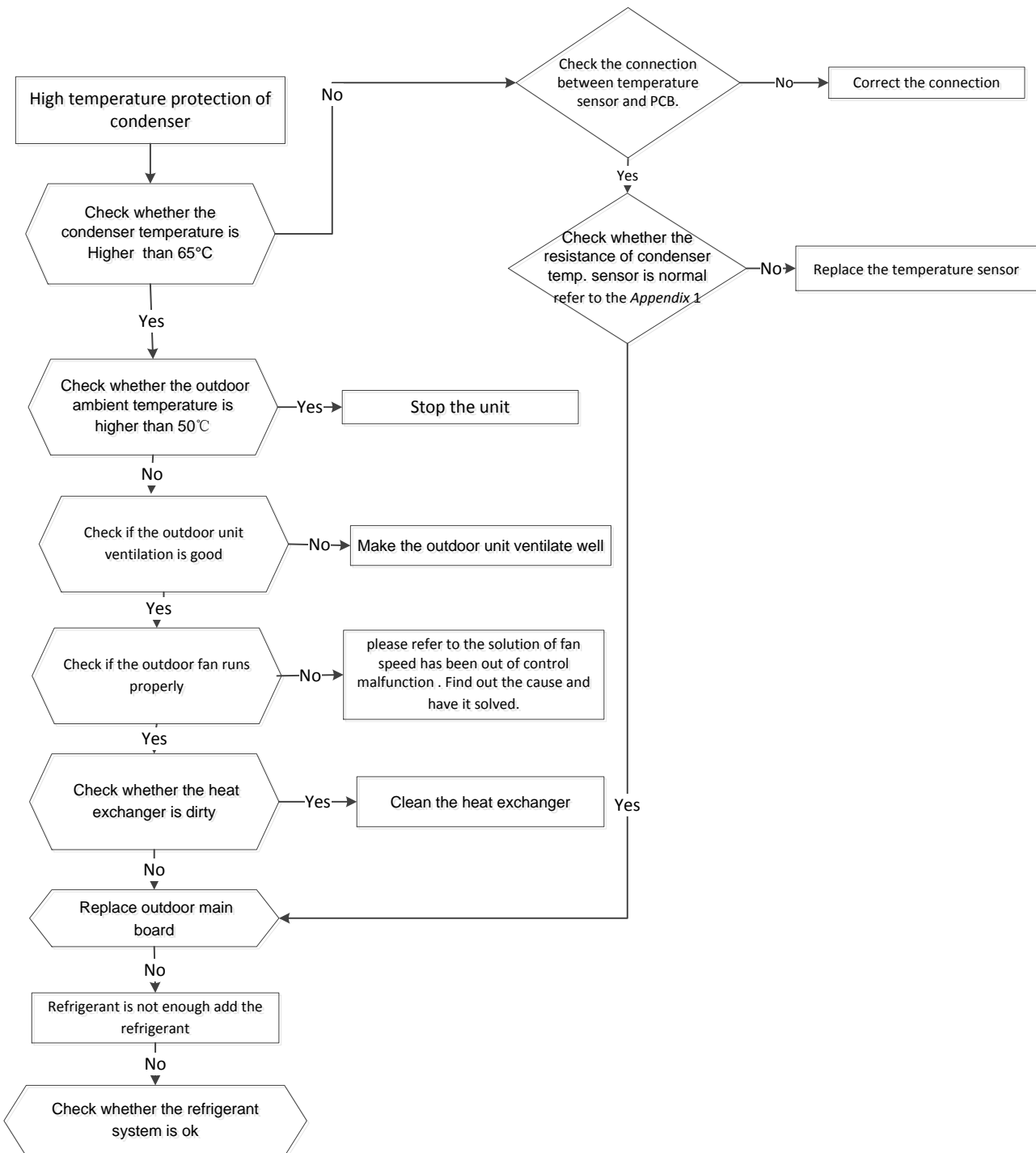

### 18.3.2.10 IPM module protection (ODU P6)

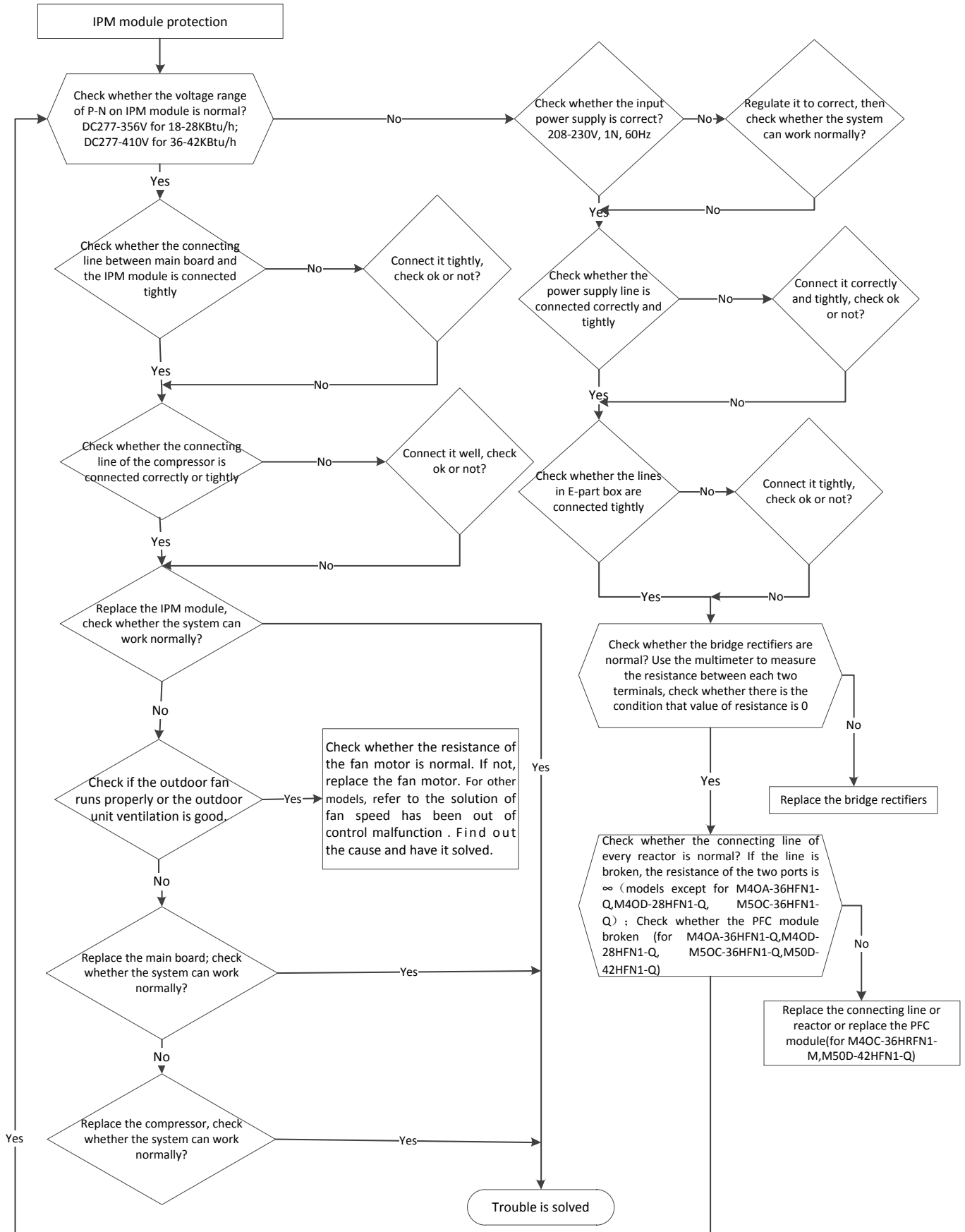

---

## 18.4 Main parts check

### 1. Temperature sensor checking

Disconnect the temperature sensor from PCB, measure the resistance value with a tester.

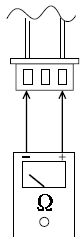

Tester

Temperature Sensors.

Room temp.(T1) sensor,

Indoor coil temp.(T2) sensor,

Outdoor coil temp.(T3) sensor,

Outdoor ambient temp.(T4) sensor,

Compressor discharge temp.(T5) sensor.

Measure the resistance value of each winding by using the multi-meter.

**Appendix 1** Temperature Sensor Resistance Value Table for T1,T2,T3,T4,T2B (°C--K)

°C	K Ohm	°C	K Ohm	°C	K Ohm	°C	K Ohm
-20	115.266	20	12.6431	60	2.35774	100	0.62973
-19	108.146	21	12.0561	61	2.27249	101	0.61148
-18	101.517	22	11.5000	62	2.19073	102	0.59386
-17	96.3423	23	10.9731	63	2.11241	103	0.57683
-16	89.5865	24	10.4736	64	2.03732	104	0.56038
-15	84.2190	25	10.000	65	1.96532	105	0.54448
-14	79.3110	26	9.55074	66	1.89627	106	0.52912
-13	74.5360	27	9.12445	67	1.83003	107	0.51426
-12	70.1698	28	8.71983	68	1.76647	108	0.49989
-11	66.0898	29	8.33566	69	1.70547	109	0.48600
-10	62.2756	30	7.97078	70	1.64691	110	0.47256
-9	58.7079	31	7.62411	71	1.59068	111	0.45957
-8	56.3694	32	7.29464	72	1.53668	112	0.44699
-7	52.2438	33	6.98142	73	1.48481	113	0.43482
-6	49.3161	34	6.68355	74	1.43498	114	0.42304
-5	46.5725	35	6.40021	75	1.38703	115	0.41164
-4	44.0000	36	6.13059	76	1.34105	116	0.40060
-3	41.5878	37	5.87359	77	1.29078	117	0.38991
-2	39.8239	38	5.62961	78	1.25423	118	0.37956
-1	37.1988	39	5.39689	79	1.21330	119	0.36954
0	35.2024	40	5.17519	80	1.17393	120	0.35982
1	33.3269	41	4.96392	81	1.13604	121	0.35042
2	31.5635	42	4.76253	82	1.09958	122	0.3413
3	29.9058	43	4.57050	83	1.06448	123	0.33246
4	28.3459	44	4.38736	84	1.03069	124	0.32390
5	26.8778	45	4.21263	85	0.99815	125	0.31559
6	25.4954	46	4.04589	86	0.96681	126	0.30754
7	24.1932	47	3.88673	87	0.93662	127	0.29974
8	22.5662	48	3.73476	88	0.90753	128	0.29216
9	21.8094	49	3.58962	89	0.87950	129	0.28482
10	20.7184	50	3.45097	90	0.85248	130	0.27770
11	19.6891	51	3.31847	91	0.82643	131	0.27078
12	18.7177	52	3.19183	92	0.80132	132	0.26408
13	17.8005	53	3.07075	93	0.77709	133	0.25757
14	16.9341	54	2.95896	94	0.75373	134	0.25125
15	16.1156	55	2.84421	95	0.73119	135	0.24512
16	15.3418	56	2.73823	96	0.70944	136	0.23916
17	14.6181	57	2.63682	97	0.68844	137	0.23338
18	13.9180	58	2.53973	98	0.66818	138	0.22776
19	13.2631	59	2.44677	99	0.64862	139	0.22231



**Appendix 2 Temperature Sensor Resistance Value Table for T5 (°C--K)**

°C	K Ohm	°C	K Ohm	°C	K Ohm	°C	K Ohm
-20	542.7	20	68.66	60	13.59	100	3.702
-19	511.9	21	65.62	61	13.11	101	3.595
-18	483	22	62.73	62	12.65	102	3.492
-17	455.9	23	59.98	63	12.21	103	3.392
-16	430.5	24	57.37	64	11.79	104	3.296
-15	406.7	25	54.89	65	11.38	105	3.203
-14	384.3	26	52.53	66	10.99	106	3.113
-13	363.3	27	50.28	67	10.61	107	3.025
-12	343.6	28	48.14	68	10.25	108	2.941
-11	325.1	29	46.11	69	9.902	109	2.86
-10	307.7	30	44.17	70	9.569	110	2.781
-9	291.3	31	42.33	71	9.248	111	2.704
-8	275.9	32	40.57	72	8.94	112	2.63
-7	261.4	33	38.89	73	8.643	113	2.559
-6	247.8	34	37.3	74	8.358	114	2.489
-5	234.9	35	35.78	75	8.084	115	2.422
-4	222.8	36	34.32	76	7.82	116	2.357
-3	211.4	37	32.94	77	7.566	117	2.294
-2	200.7	38	31.62	78	7.321	118	2.233
-1	190.5	39	30.36	79	7.086	119	2.174
0	180.9	40	29.15	80	6.859	120	2.117
1	171.9	41	28	81	6.641	121	2.061
2	163.3	42	26.9	82	6.43	122	2.007
3	155.2	43	25.86	83	6.228	123	1.955
4	147.6	44	24.85	84	6.033	124	1.905
5	140.4	45	23.89	85	5.844	125	1.856
6	133.5	46	22.89	86	5.663	126	1.808
7	127.1	47	22.1	87	5.488	127	1.762
8	121	48	21.26	88	5.32	128	1.717
9	115.2	49	20.46	89	5.157	129	1.674
10	109.8	50	19.69	90	5	130	1.632
11	104.6	51	18.96	91	4.849		
12	99.69	52	18.26	92	4.703		
13	95.05	53	17.58	93	4.562		
14	90.66	54	16.94	94	4.426		
15	86.49	55	16.32	95	4.294	B(25/50)=3950K	
16	82.54	56	15.73	96	4.167		
17	78.79	57	15.16	97	4.045	R(90°C)=5KΩ±3%	
18	75.24	58	14.62	98	3.927		
19	71.86	59	14.09	99	3.812		

## 2.Compressor checking

Measure the resistance value of each winding by using the tester.

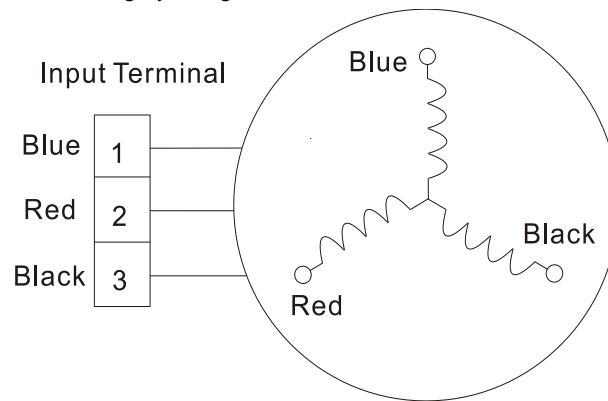

Position	Resistance Value		
	KSN140D21UFZ	KTM240D57UMT	KTF310D43UMT
Blue - Red	1.28Ω(20°C)	0.62Ω(20°C)	0.65Ω(20°C)



### 3. IPM continuity check

Turn off the power, let the large capacity electrolytic capacitors discharge completely, and dismount the IPM. Use a digital tester to measure the resistance between P and UVWN; UVW and N.

Digital tester		Normal resistance value	Digital tester		Normal resistance value
(+)Red	(-)Black		(+)Red	(-)Black	
P	N	∞ (Several MΩ)	U	N	∞ (Several MΩ)
	U		V		
	V		W		
	W		(+)Red		