



Turn to the experts

Service Manual for QHB Series Product

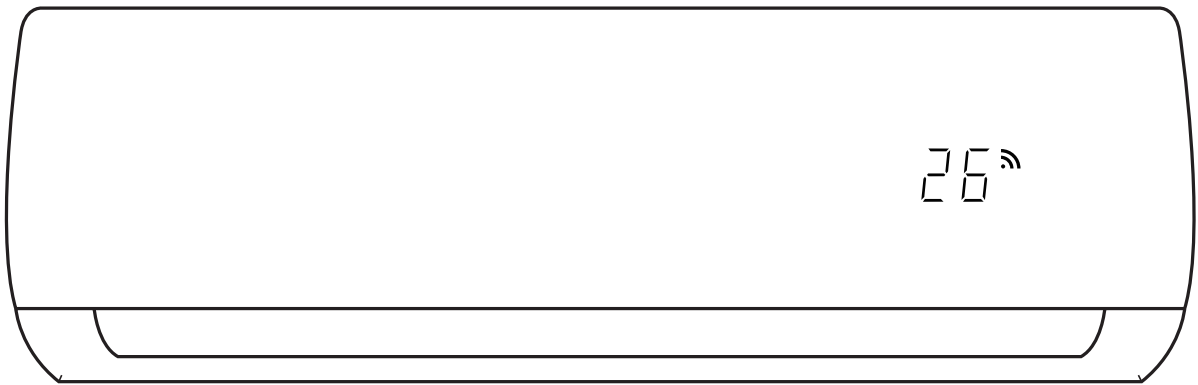

Table of Contents

Page

1. Safety Precautions	1
1. In case of Accidents or Emergency	
2. Pre-Installation and Installation	
3. Operation and Maintenance	
2. Specifications	3
1. Model Reference	
2. Electrical Wiring Diagrams	
3. Product Features	9
1. Operation Modes and Functions	
4. Maintenance and Disassembly	17
1. Maintenance	
2. Disassembly	
5. Troubleshooting	60
1. Safety Caution	
2. General Troubleshooting	
3. Error Diagnosis and Troubleshooting Without Error Code	
4. Quick Maintenance by Error Code	
5. Troubleshooting by Error Code	
Appendix	87
i) Temperature Sensor Resistance Value Table for T1,T2,T3 and T4 (°C – K)	
ii) Temperature Sensor Resistance Value Table for TP (°C --K)	
iii) Pressure On Service Port	

Safety Precautions

Contents

1.	In Case of Accidents or Emergency	2
2.	Pre-Installation.....	2
3.	Operation and Maintenance.....	2

To prevent personal injury, or property or unit damage, adhere to all precautionary measures and instructions outlined in this manual. Before servicing a unit, refer to this service manual and its relevant sections.

Failure to adhere to all precautionary measures listed in this section may result in personal injury, damage to the unit or to property, or in extreme cases, death.

! **WARNING** indicates a potentially hazardous situation which if not avoided could result in serious personal injury, or death.

! **CAUTION** indicates a potentially hazardous situation which if not avoided could result in minor or moderate personal injury, or unit damage.

1. In case of Accidents or Emergency

! WARNING

- If a gas leak is suspected, immediately turn off the gas and ventilate the area if a gas leak is suspected before turning the unit on.
- If strange sounds or smoke is detected from the unit, turn the breaker off and disconnect the power supply cable.
- If the unit comes into contact with liquid, contact an authorized service center.
- If liquid from the batteries makes contact with skin or clothing, immediately rinse or wash the area well with clean water.
- Do not insert hands or other objects into the air inlet or outlet while the unit is plugged in.
- Do not operate the unit with wet hands.
- Do not use a remote controller that has previously been exposed to battery damage or battery leakage.

! CAUTION

- Clean and ventilate the unit at regular intervals when operating it near a stove or near similar devices.
- Do not use the unit during severe weather conditions. If possible, remove the product from the window before such occurrences.

2. Pre-Installation and Installation

! WARNING

- Use this unit only on a dedicated circuit.
- Damage to the installation area could cause the unit to fall, potentially resulting in personal injury, property damage, or product failure.
- Only qualified personnel should disassemble, install, remove, or repair the unit.
- Only a qualified electrician should perform electrical work. For more information, contact your dealer, seller, or an authorized Midea service center.

! CAUTION

- While unpacking be careful of sharp edges around the unit as well as the edges of the fins on the condenser and evaporator.

3. Operation and Maintenance

! WARNING

- Do not use defective or under-rated circuit breakers.
- Ensure the unit is properly grounded and that a dedicated circuit and breaker are installed.
- Do not modify or extend the power cable. Ensure the power cable is secure and not damaged during operation.
- Do not unplug the power supply plug during operation.
- Do not store or use flammable materials near the unit.
- Do not open the inlet grill of the unit during operation.
- Do not touch the electrostatic filter if the unit is equipped with one.
- Do not block the inlet or outlet of air flow to the unit.
- Do not use harsh detergents, solvents, or similar items to clean the unit. Use a soft cloth for cleaning.
- Do not touch the metal parts of the unit when removing the air filter as they are very sharp.
- Do not step on or place anything on the unit or outdoor units.
- Do not drink water drained from the unit
- Avoid direct skin contact with water drained from the unit.
- Use a firm stool or step ladder according to manufacturer procedures when cleaning or maintaining the unit.

! CAUTION

- Do not install or operate the unit for an extended period of time in areas of high humidity or in an environment directly exposing it to sea wind or salt spray.
- Do not install the unit on a defective or damaged installation stand, or in an unsecure location.
- Ensure the unit is installed at a level position
- Do not install the unit where noise or air discharge created by the outdoor unit will negatively impact the environment or nearby residences.
- Do not expose skin directly to the air discharged by the unit for prolonged periods of time.
- Ensure the unit operates in areas water or other liquids.
- Ensure the drain hose is installed correctly to ensure proper water drainage.
- When lifting or transporting the unit, it is recommended that two or more people are used for this task.
- When the unit is not to be used for an extended time, disconnect the power supply or turn off the breaker.

Specifications

Contents

1.	Model Reference	4
2.	Electrical Wiring Diagrams	5
2.1	Indoor Unit.....	5
2.2	Outdoor Unit.....	7

1. Model Reference

Refer to the following table to determine the specific indoor and outdoor unit model number of your purchased equipment.

Indoor Unit Model	Outdoor Unit Model	Capacity (Btu)	Power Supply
42QHB09D8S* 42QHB09E8S*	38QHB09D8S* 38QHB09E8S*	9k	220-240V~, 50Hz, 1Phase
42QHB12D8S* 42QHB12E8S*	38QHB12D8S* 38QHB12E8S*	12k	
42QHB18D8S*	38QHB18D8S*	18k	
42QHB24D8S*	38QHB24D8S*	24k	

2. Electrical Wiring Diagrams

2.1 Indoor unit

Abbreviation	Paraphrase
Y/G	Yellow-Green Conductor
ION	Positive and Negative Ion Generator
CAP	Capacitor
PLASMA	Electronic Dust Collector
L	LIVE
N	NEUTRAL
Heater	The Electric Heating Belt of Indoor Unit
T1	Indoor Room Temperature
T2	Coil Temperature of Indoor Heat Exchanger

Indoor Wiring Diagram

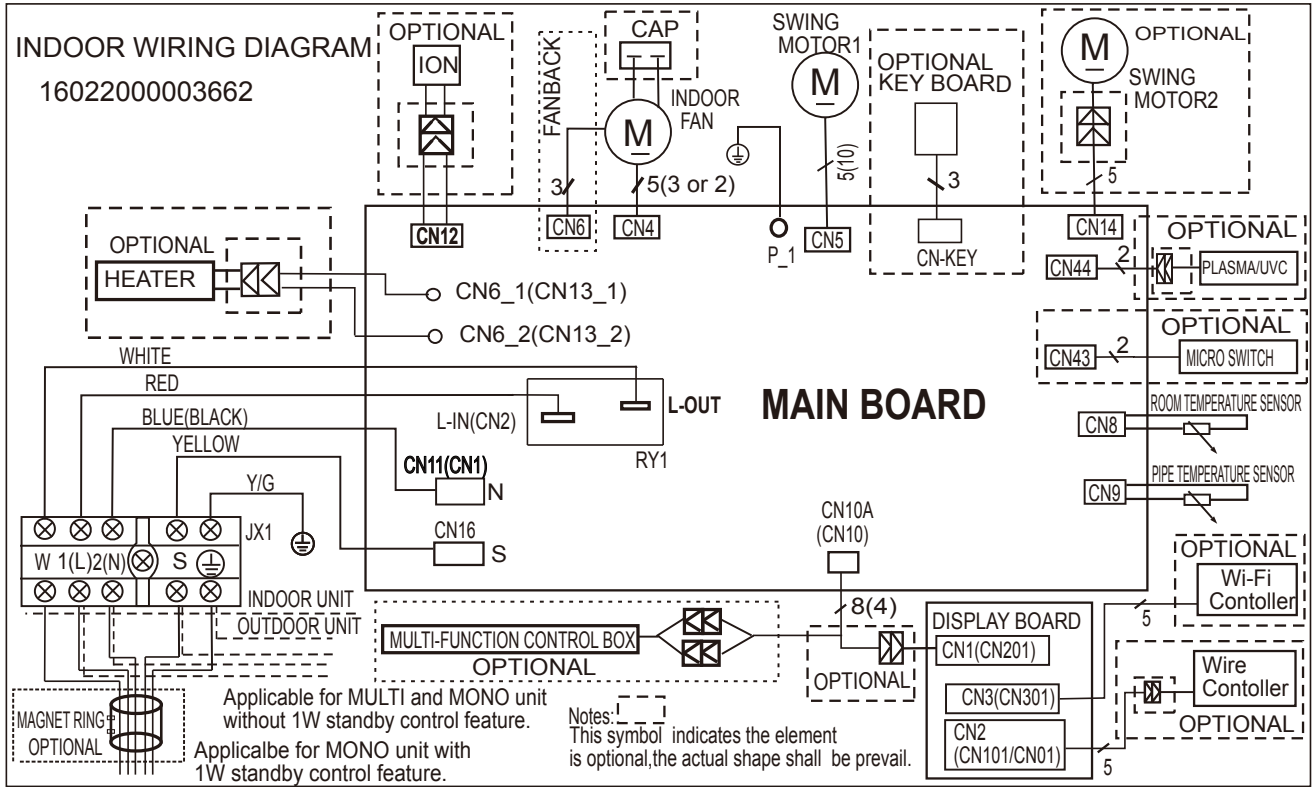

2.2 Outdoor Unit

Abbreviation	Paraphrase
4-WAY	Gas Valve Assembly/4-WAY VALVE
AC-FAN	Alternating Current FAN
DC-FAN	Direct Current FAN
CT1	AC Current Detector
COMP	Compressor
T3	Coil Temperature of Condenser
T4	Outdoor Ambient Temperature
TH	Compressor Suction Temperature
TP	Compressor Discharge Temperature
EEV	Electric Expansive Valve
L-PRO	Low Pressure Switch
H-PRO	High Pressure Switch

18K+24K

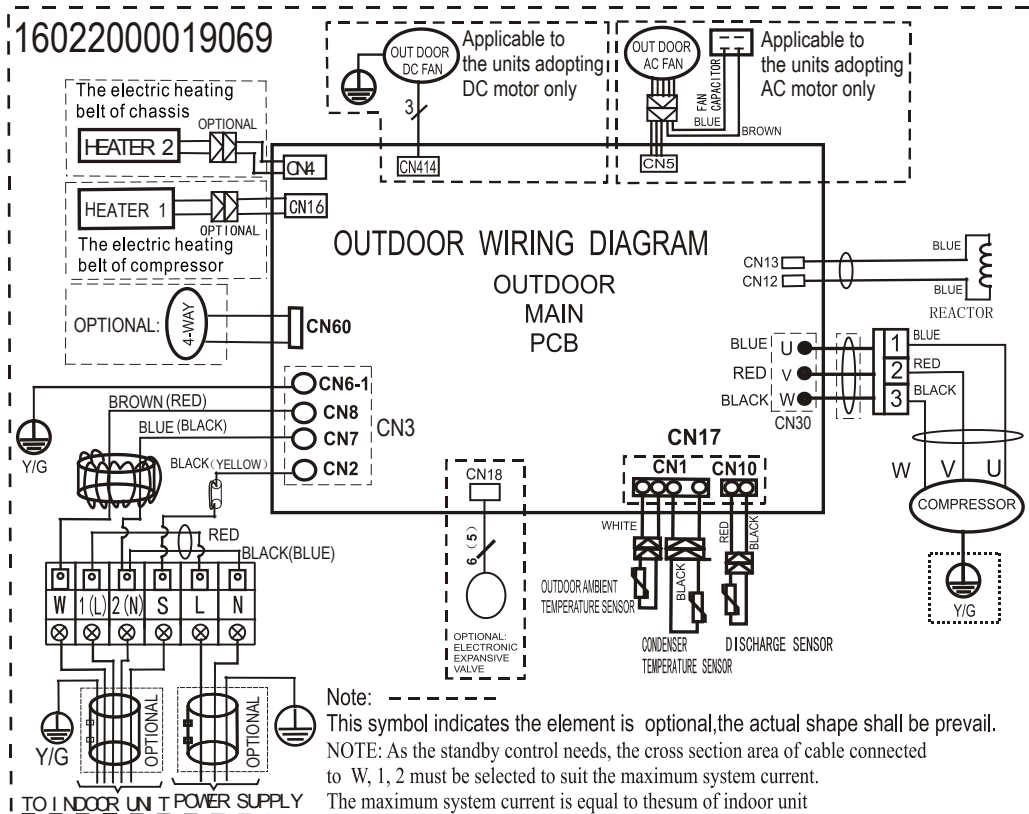

9K+12K

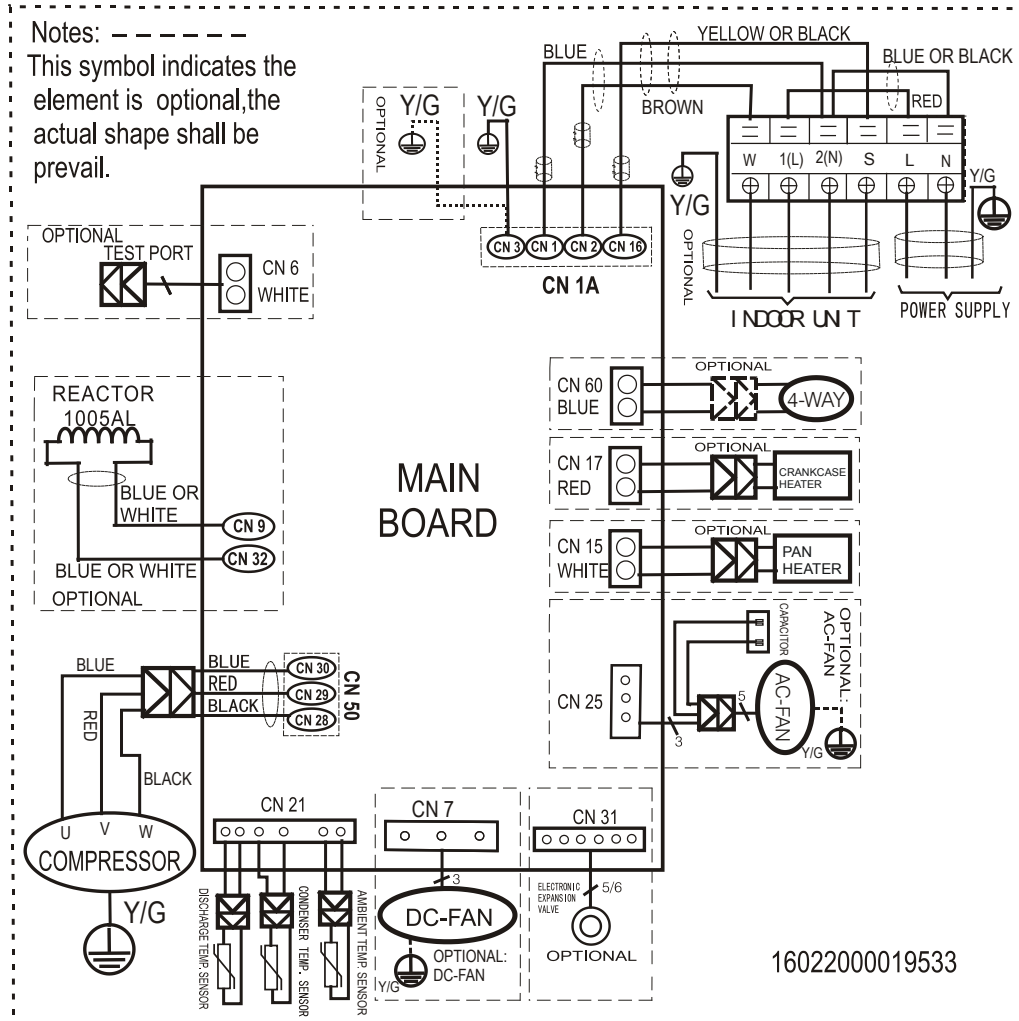

Product Features

Contents

1.	Operation Modes and Functions	10
1.1	Abbreviation.....	10
1.2	Safety Features	10
1.3	Display Function	10
1.4	Fan Mode.....	11
1.5	Cooling Mode	11
1.6	Heating Mode (For heat pump models).....	11
1.7	Auto-mode.....	12
1.8	Drying Mode	12
1.9	Forced Operation Function	12
1.10	Timer Function	13
1.11	Sleep Function.....	13
1.12	Auto-Restart Function.....	13
1.13	Refrigerant Leakage Detection.....	13
1.14	Louver Position Memory Function	13
1.15	8°C Heating(Optional)	13
1.16	Self Clean(Optional).....	13
1.17	Follow Me(Optional)	14
1.18	Silence (Optional).....	14
1.19	Information Inquiry.....	14

1. Operation Modes and Functions

1.1 Abbreviation

Unit element abbreviations

Abbreviation	Element
T1	Indoor room temperature
T2	Coil temperature of evaporator
T3	Coil temperature of condenser
T4	Outdoor ambient temperature
TP	Compressor discharge temperature

1.2 Safety Features

Compressor three-minute delay at restart

Compressor functions are delayed for up to one minute upon the first startup of the unit, and are delayed for up to three minutes upon subsequent unit restarts.

Automatic shutoff based on discharge temperature

If the compressor discharge temperature exceeds 115°C for five seconds, the compressor ceases operation.

Automatic shutoff based on fan speed

If the indoor fan speed registers below 300RPM for an extended period of time, the unit ceases operation and the corresponding error code is displayed on the indoor unit.

Inverter module protection

The inverter module has an automatic shutoff mechanism based on the unit's current, voltage, and temperature. If automatic shutoff is initiated, the corresponding error code is displayed on the indoor unit and the unit ceases operation.

Indoor fan delayed operation

- When the unit starts, the louver is automatically activated and the indoor fan will operate after a period of 7 seconds.
- If the unit is in heating mode, the indoor fan is regulated by the anti-cold wind function.

Compressor preheating

Preheating is automatically activated when T4 sensor is lower than 3°C.

Sensor redundancy and automatic shutoff

- If one temperature sensor malfunctions, the air conditioner continues operation and displays the corresponding error code, allowing for emergency use.

- When more than one temperature sensor is malfunctioning, the air conditioner ceases operation.

Refrigerant leakage detection

This function is active only when mode is selected. It will detect if the compressor is being damaged by refrigerant leakage or by compressor overload. This is measured using the coil temperature of evaporator T2 when the compressor is in operation.

1.3 Display Function

Unit display functions



Function	Display
Temperature	Set temperature value
Temperature (fan and Drying mode)	Room temperature
Activation of Timer ON, Fresh, Swing, Turbo, or Silent	0n (3s)
Cancellation of Timer OFF, Fresh, Swing, Turbo, or Silent	0F (3s)
Defrost	dF
Warming in heating mode	cF
Self-clean (available on select units only)	SC
Heating in room temperature under 8°C	FP
WiFi control (available on select units only)	
ECO function (available on select units only)	E → C → 0 → set temperature → E gradually illuminates to 88n one second interval

1.4 Fan Mode

When fan mode is activated:

- The outdoor fan and compressor are stopped.
- Temperature control is disabled and no temperature setting is displayed.
- The indoor fan speed can be set to high, med, low, or auto.
- The louver operations are identical to those in cooling mode.
- Auto fan: In fan-only mode, AC operates the same as auto fan in cooling mode with the temperature set at 24°C.

1.5 Cooling Mode

Cooling temperature compensation (ΔT_5) is a well-setting parameter of EEPROM. The default value is 0. The compressor ceases operation when $T_1 - T_s < -2$.

1.5.1 Compressor Control

ΔT is the programmed parameter of temperature compensation.

- When $T_1 - T_s < \Delta T - 2^\circ\text{C}$, the compressor ceases operation.
- When $T_1 - T_s > \Delta T + 3^\circ\text{C}$, the compressor continues operation.
- When the AC is operating in mute mode, the compressor operates at a low frequency.
- When the current exceeds the preset value, the current protection function activates and the compressor ceases operation.

1.5.2 Indoor Fan Control

- In cooling mode, the indoor fan operates continuously. The fan speed can be set to high, medium, low, or auto.
- If the compressor ceases operations when the configured temperature is reached, the indoor fan motor operates at the minimum or configured speed.

1.5.3 Outdoor Fan Control

- For different outdoor units, the fan speeds are different.
- For 9K and 12K, outdoor fan speed is controlled by T4 and compressor frequency.
- For 18K and 24K models, the fan speed is controlled by T4

1.5.4 Condenser Temperature Protection

For 18K and 24K model

- When $TP_3 < T_3 < TP_3 + 5$, the compressor frequency will decrease to the lower level until to F1 and then runs at F1. If $TP_3 - 3 < T_3 < TP_3$, the compressor will keep running at the current frequency.
- When $T_3 < TP_3 - 3$, the compressor will not limit the frequency and resume to the former frequency.
- When $T_3 > TP_3 + 5$ for 5 seconds, the compressor will stop until $T_3 < TP_3 - 3$.

For 9K and 12K model

- When $TP_3 < T_3 < TP_4$, the compressor frequency will decrease to the lower level until to F1 and then runs at F1. If $TP_2 < T_3 < TP_3$, the compressor will keep running at the current frequency.
- When $T_3 < TP_1$, the compressor will not limit the frequency and resume to the former frequency.
- When $T_3 > TP_4$ for 9 seconds, the compressor will stop until $T_3 < TP_2 - 1$.

1.5.5 Evaporator Temperature Protection

When evaporator temperature drops below a configured value, the compressor ceases operations.

1.6 Heating Mode (For heat pump models)

Heating temperature compensation (ΔT_3) is a well-setting parameter of EEPROM. Its value ranges from -6°C to 6°C .

1.6.1 Compressor Control

- When $T_1 - T_s > -\Delta T$, the compressor ceases operation.
- When $T_1 - T_s < -\Delta T - 1.5^\circ\text{C}$, the compressor continues operation.
- When the AC is operating in mute mode, the compressor operates at a low frequency.
- When the current exceeds the preset value, the current protection function activates and the compressor ceases operation.

1.6.2 Indoor Fan Control:

- When the compressor is on, the indoor fan can be set to high/med/low/auto. And the anti-cold wind function has the priority.
- The indoor fan speed will adjust according to the value

of T1-T5.

1.6.3 Outdoor Fan Control:

- For 9K and 12K, outdoor fan speed is controlled by T4 and compressor frequency.
- For 18K and 24K models, the fan speed is controlled by T4

1.6.4 Defrosting mode

For 9K and 12K model

- The unit enters defrosting mode according to the value of temperature of T3 and the value of temperature of T4 as well as the compressor running time.
- In defrosting mode, the compressor continues to run, the indoor and outdoor motor will cease operation, the defrost light of the indoor unit will turn on, and the “” symbol is displayed.
- If any one of the following conditions is satisfied, defrosting ends and the machine switches to normal heating mode:
 - T3 rises above TCDE1°C.
 - T3 maintained above TCDE2°C for 80 seconds.
 - Unit runs for 15 minutes consecutively in defrosting mode.

For 18K and 24K model

- The unit enters defrosting mode according to the value of temperature of T3 and the value range of temperature change of T3 as well as the compressor running time.
- In defrosting mode, the compressor continues to run, the indoor and outdoor motor will cease operation, the defrost light of the indoor unit will turn on, and the “” symbol is displayed.
- If any one of the following conditions is satisfied, defrosting ends and the machine switches to normal heating mode:
 - T3 rises above TCDE1°C.

- T3 maintained above TCDE2°C for 80 seconds.
- Unit runs for 10 minutes consecutively in defrosting mode.

1.6.5 Evaporator Temperature Protection

- When $T2 > T_{Estop}$, the compressor frequency will cease operation until $T2 < T_{EH2}$.
- When $T_{Edown} < T2 < T_{Estop}$, the compressor frequency will decrease to the lower level
- When $REH2 < T2 < T_{Estop}$, the compressor will keep running at the current frequency.
- When $T2 < T_{EH2}$, the compressor will not limit the frequency and resume to the former frequency.

1.7 Auto-mode

- This mode can be selected with the remote controller.
- In auto mode, the machine selects cooling, heating, or fan-only mode on the basis of ΔT ($\Delta T = T1 - T_s$).

ΔT	Running mode
$\Delta T > 2\text{ }^{\circ}\text{C}$	Cooling
$-2\text{ }^{\circ}\text{C} \leq \Delta T \leq 2\text{ }^{\circ}\text{C}$	Fan-only
$\Delta T < -2\text{ }^{\circ}\text{C}$	Heating*

Heating*: In auto mode, cooling only models run the fan

- The louver operates same as in relevant mode.
- If the machine switches mode between heating and cooling, the compressor will keep stopping for 15 minutes and then choose mode according to T1-Ts.
- If the setting temperature is modified, the machine will choose running function again.

1.8 Drying mode

- Indoor fan speed is fixed at breeze and can't be changed. The louver angle is the same as in cooling mode.
- All protections are active and the same as that in cooling mode.

1.9 Forced operation function

- Forced cooling mode:

The compressor and outdoor fan continue to run and the indoor fan runs at low speed. After running for 30 minutes, the AC will switch to auto mode with a preset temperature of 24°C.

- Forced auto mode:

Forced auto mode operates the same as normal auto mode with a preset temperature of 24°C.

- The unit exits forced operation when it receives the following signals:
 - Switch on
 - Switch off
 - Timer on
 - Timer off
 - Changes in:
 - mode
 - fan speed
 - sleeping mode
 - Follow me

1.10 Timer function

- Timing range is 24 hours.
 - Timer on. The machine will turn on automatically when reaching the setting time.
 - Timer off. The machine will turn off automatically when reaching the setting time.
 - Timer on/off. The machine will turn on automatically when reaching the setting "on" time, and then turn off automatically when reaching the setting "off" time.
 - Timer off/on. The machine will turn off automatically when reaching the setting "off" time, and then turn on automatically when reaching the setting "on" time.
 - The timer function will not change the AC current operation mode. Suppose AC is off now, it will not start up firstly after setting the "timer off" function. And when reaching the setting time, the timer LED will be off and the AC running mode has not been changed.
 - The setting time is relative time.
 - The AC will quit the timer function when it has malfunction.

1.11 Sleep function

- The sleep function is available in cooling, heating, or auto mode.
- The operational process for sleep mode is as follows:
 - When cooling, the temperature rises 1°C (to not higher than 30°C) every hour. After 2 hours, the temperature stops rising and the indoor fan is fixed at low speed.
 - When heating, the temperature decreases 1°C (to not lower than 17°C) every hour. After 2 hours, the temperature stops decreasing and the indoor fan is

fixed at low speed. Anti-cold wind function takes priority.

- The operating time for sleep mode is 7 hours, after which, the unit exits this mode and switches off.
- The timer setting is available in this mode.

1.12 Auto-Restart function

- The indoor unit has an auto-restart module that allows the unit to restart automatically. The module automatically stores the current settings (not including the swing setting) and, in the case of a sudden power failure, will restore those setting automatically within 3 minutes after power returns.
- If the unit was in forced cooling mode, it will run in this mode for 30 minutes and turn to auto mode with temperature set to 24°C.
- If there is a power failure while the unit is running, the compressor starts 3 minutes after the unit restarts. If the unit was already off before the power failure, the compressor starts 1 minute after the unit restarts.

1.13 Refrigerant Leakage Detection

With this new technology, the display area will show "EC" when the outdoor unit detects refrigerant leakage. This function is only available in cooling mode.

1.14 Louver Position Memory Function

When starting the unit again after shutting down, its louver will restore to the angle originally set by the user, but the precondition is that the angle must be within the allowable range, if it exceeds, it will memorize the maximum angle of the louver. During operation, if the power fails or the end user shuts down the unit in the turbo mode, the louver will restore to the default angle.

1.15 8°C Heating(Optional)

In heating mode, the temperature can be set to as low as 8°C, preventing the indoor area from freezing if unoccupied during severe cold weather.

1.16 Self clean(Optional)

- If you press "Self Clean" when the unit is in cooling or drying mode:
 - For cooling models, the indoor unit will run in low fan mode for a certain time, then ceases operation.
 - For heat pump models, the indoor unit will run in fan-only mode, then low heat, and finally in fan-only mode.

-
- Self Clean keeps the indoor unit dry and prevents mold growth.

1.17 Follow me(Optional)

- If you press “Follow Me” on the remote, the indoor unit will beep. This indicates the follow me function is active.
- Once active, the remote control will send a signal every 3 minutes, with no beeps. The unit automatically sets the temperature according to the measurements from the remote control.
- The unit will only change modes if the information from the remote control makes it necessary, not from the unit’s temperature setting.
- If the unit does not receive a signal for 7 minutes or you press “Follow Me,” the function turns off. The unit regulates temperature based on its own sensor and settings.

1.18 Silence (Optional)

Press “Silence” on the remote control to enable the SILENCE function. While this function is active, the compressor frequency is maintained at a lower level than F2. The indoor unit will run at faint breeze, which reduces noise to the lowest possible level.

1.19 Information Inquiry

- To enter information inquiry status, complete the following procedure within ten seconds:
 - Press LED 3 times.
 - Press SWING 3 times.
- If you are successful, you will hear beeps for two seconds.
- Use the LED and SWING buttons to cycle through information displayed.
- Pressing LED will display the next code in the sequence. Pressing SWING will show the previous.
- The following table shows information codes. The screen will display this code for two seconds, then the information for 25 seconds.

Displayed code	Explanation	Displayed value	Meaning	Additional Notes
T1	Room temperature	-1F,-1E,-1d,-1c,-1b,-1A -19—99 A0,A1,...A9 b0,b1,...b9 c0,c1,...c9 d0,d1,...d9 E0,E1,...E9 F0,F1,...F9	-25,-24,-23,-22,-21,-20 -19—99 100,101,...109 110,111,...119 120,121,...129 130,131,...139 140,141,...149 150,151,...159	<ol style="list-style-type: none"> All displayed temperatures use actual values. All temperatures are displayed in °C regardless of remote used. T1, T2, T3, T4, and T2B display ranges from -25 to 70 °C. TP display ranges from -20 to 130 °C. The frequency display ranges from 0 to 159HZ. If the actual values exceed or fall short of the defined range, the values closest to the maximum and minimum values will be displayed.
T2	Indoor coil temperature			
T3	Outdoor coil temperature			
T4	Ambient temperature			
T2B	Outlet temperature of indoor coil			
TP	Discharge temperature			
TH	Suction temperature			
FT	Targeted frequency			
FR	Actual frequency			
IF	Indoor fan speed	0 1,2,3,4	OFF Low speed, Medium speed, High speed, Turbo.	N/A Used for some large capacity motors.
OF	Outdoor fan speed	14-FF	Actual fan speed is equal to the display value converted to decimal value and multiplied by 10. This is measured in RPM.	Used for some small capacity motors. The display value is 14-FF (hexadecimal). The corresponding fan speed ranges from 200 to 2550RPM.
LR	EXV opening angle	0-FF	Actual EXV opening value is equal to the display value converted to decimal value and then multiplied by 2.	-
CT	Compressor continuous running time	0-FF	0-255 minutes	If the actual value exceeds or falls short of the defined range, the value closest to the maximum and minimum will be displayed.
ST	Causes of compressor stop	0-99	For a detailed explanation, contact technical support.	-

Displayed code	Explanation	Displayed value	Meaning	Additional Notes
R0	Reserved	0-FF	-	-
R1				
b0				
b1				
b2				
b3				
b4				
b5				
b6				
dL				
Rc				
Uo				
Td				
dR				
dS				
dT				

Maintenance and Disassembly

Contents

1.	Maintenance	18
1.1	First Time Installation Check	18
1.2	Refrigerant Recharge	20
1.3	Re-Installation	21
1.3.1	Indoor Unit	21
1.3.2	Outdoor Unit	23
2.	Disassembly	25
2.1	Indoor Unit.....	25
2.2	Outdoor Unit.....	41

1. Maintenance

1.1 First Time Installation Check

Air and moisture trapped in the refrigerant system affects the performance of the air conditioner by:

- Increasing pressure in the system.
- Increasing the operating current.
- Decreasing the cooling or heating efficiency.
- Congesting the capillary tubing due to ice build-up in the refrigerant circuit.
- Corroding the refrigerant system.

To prevent air and moisture from affecting the air conditioner's performance, the indoor unit, as well as the pipes between the indoor and outdoor unit, must be leak tested and evacuated.

Leak test (soap water method)

Use a soft brush to apply soapy water or a neutral liquid detergent onto the indoor unit connections and outdoor unit connections. If there is gas leakage, bubbles will form on the connection.

Air purging with vacuum pump

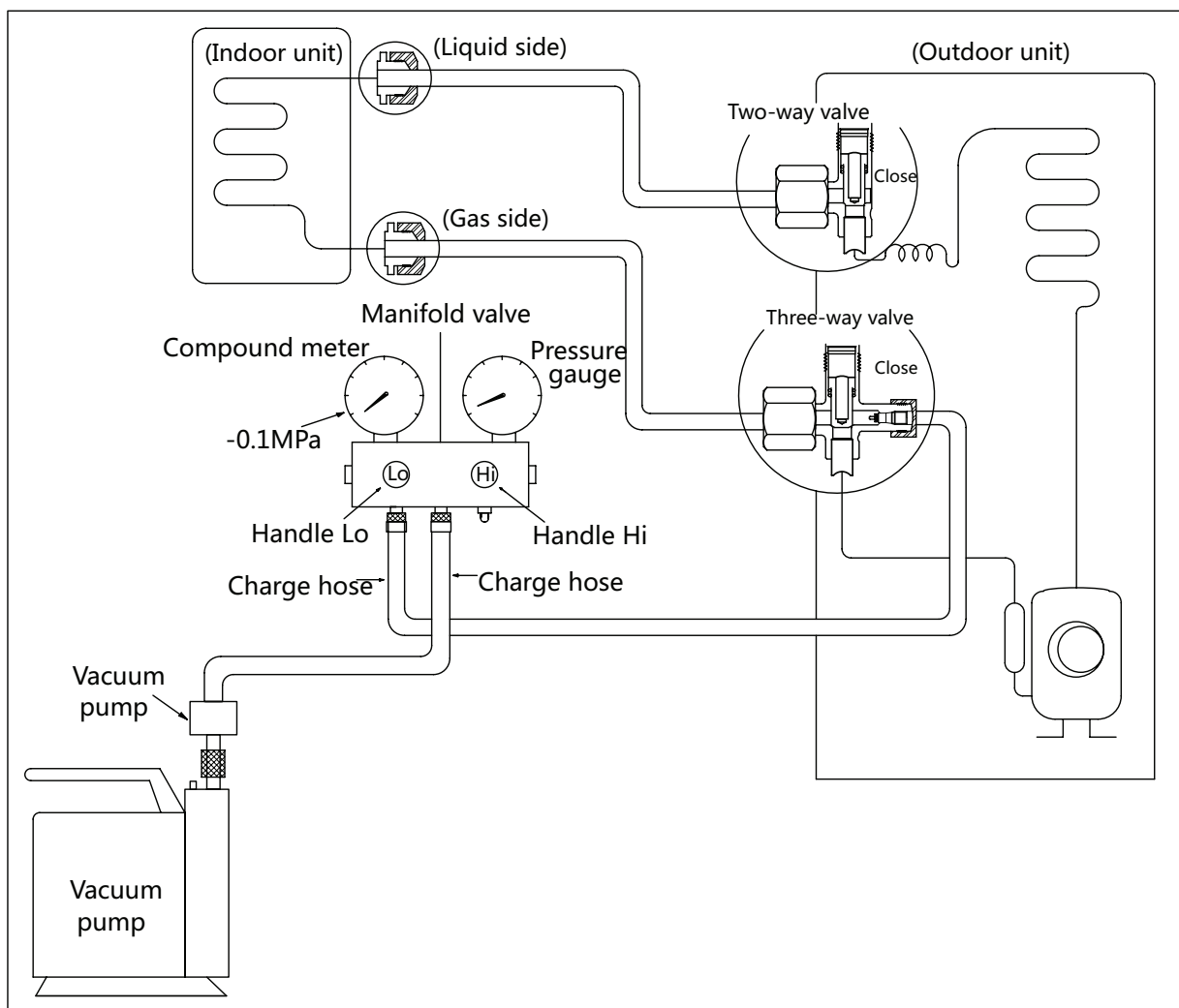

Procedure:

1. Tighten the flare nuts of the indoor and outdoor units, and confirm that both the 2- and 3-way valves are closed.
2. Connect the charge hose with the push pin of Handle Lo to the gas service port of the 3-way valve.
3. Connect the charge hose of Handle Hi connection to the vacuum pump.
4. Fully open the Handle Lo manifold valve.
5. Using the vacuum pump, evacuate the system for 30 minutes.
 - a. Check whether the compound meter indicates -0.1 MPa (14.5 Psi).
 - If the meter does not indicate -0.1 MPa (14.5 Psi) after 30 minutes, continue evacuating for an additional 20 minutes.
 - If the pressure does not achieve -0.1 MPa (14.5 Psi) after 50 minutes, check for leakage.
 - If the pressure successfully reaches -0.1 MPa (14.5 Psi), fully close the Handle Lo valve and cease vacuum pump operations.
 - b. Wait for 5 minutes then check whether the gauge needle moves after turning off the vacuum pump.
6. Loosen the flare nut of the 3-way valve for 6 or 7 seconds and then tighten the flare nut again.
 - a. Confirm the pressure display in the pressure indicator is slightly higher than the atmospheric pressure.
 - b. Remove the charge hose from the 3-way valve.
7. Fully open the 2- and 3-way valves and tighten the cap of the 3-way valve.

1.2 Refrigerant Recharge

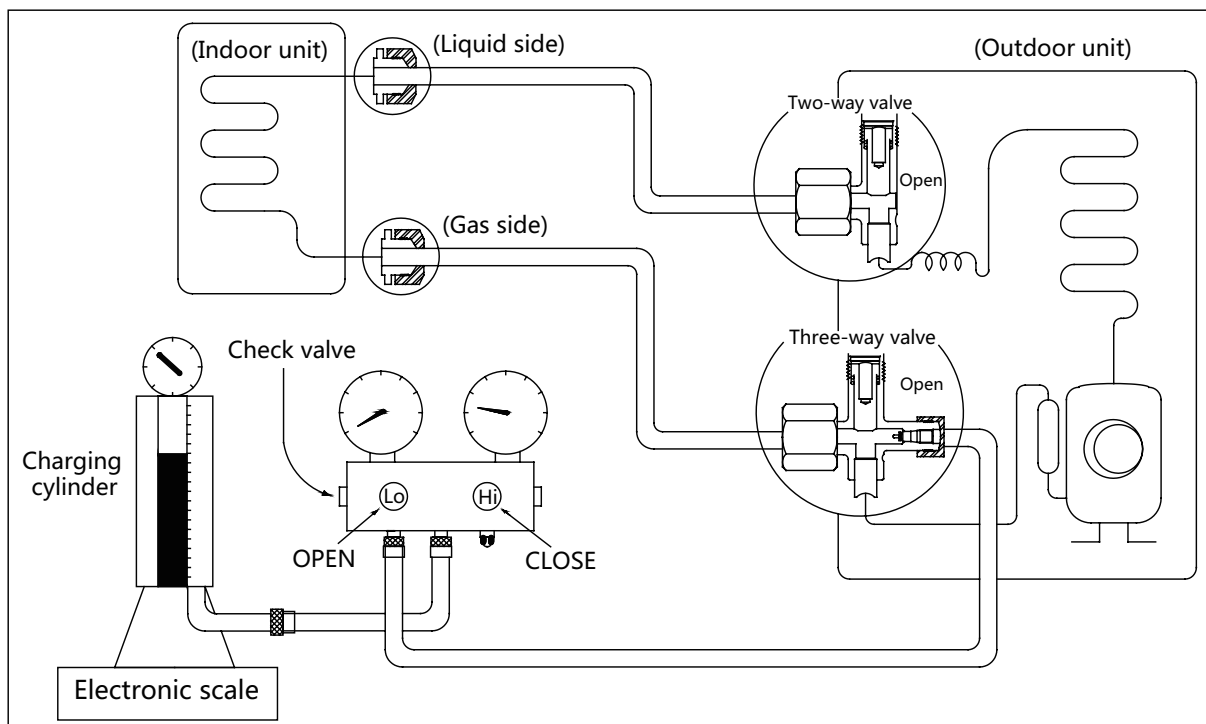

Prior to recharging the refrigerant, confirm the additional amount of refrigerant required using the following table:

Models	Standard length	Max. elevation	Max. length	Additional refrigerant
9k-12k	5m (16.4ft)	10m (32.8ft)	25m (82.0ft)	15g/m (0.16oz/ft)
18k	5m (16.4ft)	20m (65.6ft)	30m (98.4ft)	15g/m (0.16oz/ft)
24	5m (16.4ft)	25m (82.0ft)	50m (164ft)	30g/m (0.32oz/ft)

Procedure:

1. Close both 2- and 3-way valves.
2. Slightly connect the Handle Lo charge hose to the 3-way service port.
3. Connect the charge hose to the valve at the bottom of the cylinder.
4. If the refrigerant is R410A, invert the cylinder to ensure a complete liquid charge.
5. Open the valve at the bottom of the cylinder for 5 seconds to purge the air in the charge hose, then fully tighten the charge hose with push pin Handle Lo to the service port of 3-way valve..
6. Place the charging cylinder onto an electronic scale and record the starting weight.
7. Fully open the Handle Lo manifold valve, 2- and 3-way valves.
8. Operate the air conditioner in cooling mode to charge the system with liquid refrigerant.
9. When the electronic scale displays the correct weight (refer to the gauge and the pressure of the low side to confirm), turn off the air conditioner, then disconnect the charge hose from the 3-way service port immediately..
10. Mount the caps of service port and 2- and 3-way valves.
11. Use a torque wrench to tighten the caps to a torque of 18 N.m.
12. Check for gas leakage.

1.3 Re-Installation

1.3.1 Indoor Unit

Collecting the refrigerant into the outdoor unit

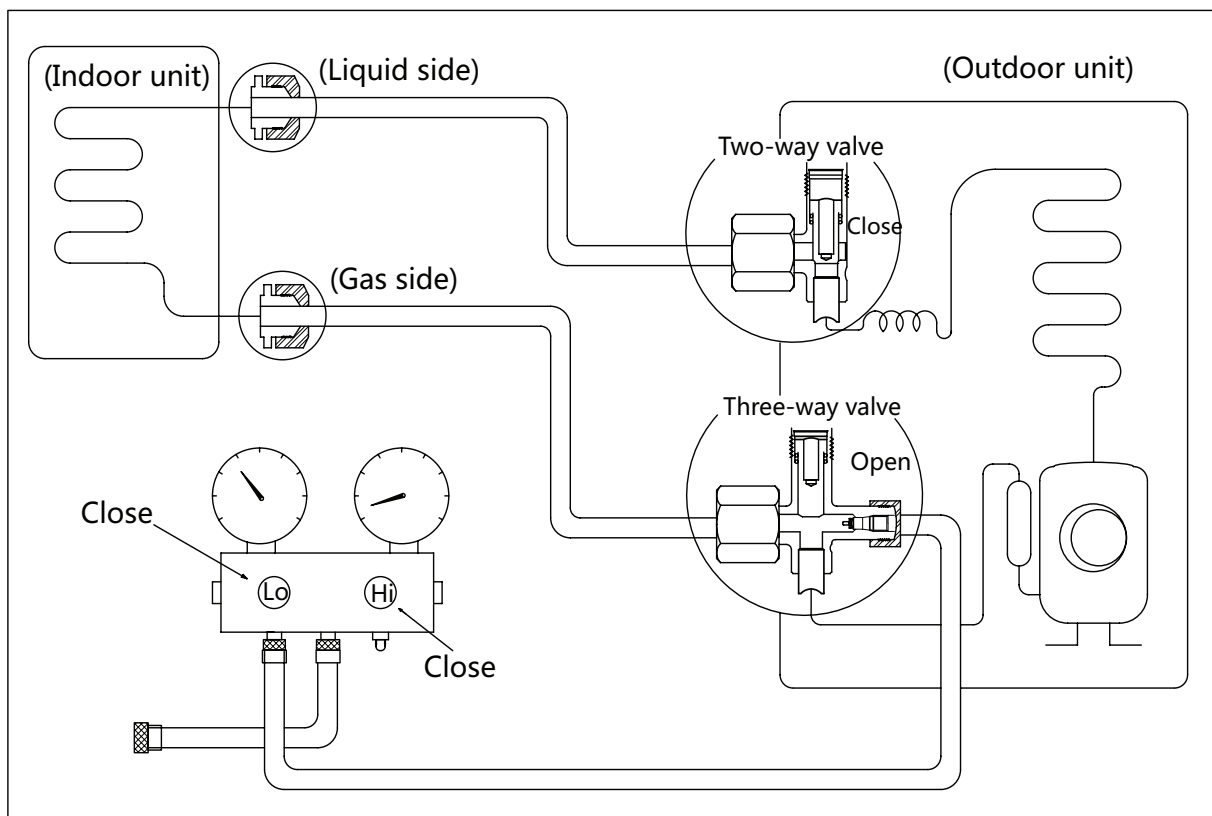

Procedure:

1. Confirm that the 2- and 3-way valves are opened.
2. Remove the valve stem caps and ensure that the valve stems are opened (use as hexagonal wrench to open the valve stems).
3. Connect the charge hose with the push pin of Handle Lo to the 3-way valve's gas service port.
4. Open the Handle Lo valve of the manifold valve to purge air from the charge hose for 5 seconds and then close it quickly.
5. Close the 2-way valve.
6. Operate the air conditioner in cooling mode. Cease operations when the gauge reaches 0.1 MPa (14.5 Psi).
7. Close the 3-way valve so that the gauge rests between 0.3 MPa (43.5 Psi) and 0.5 MPa (72.5 Psi).
8. Disconnect the charge set, and tighten the 2- and 3-way valve's stem nuts (use a torque wrench to tighten the 3-way valves service port cap to a torque of 18 N.m).
9. Check for gas leakage.

Air purging with vacuum pump

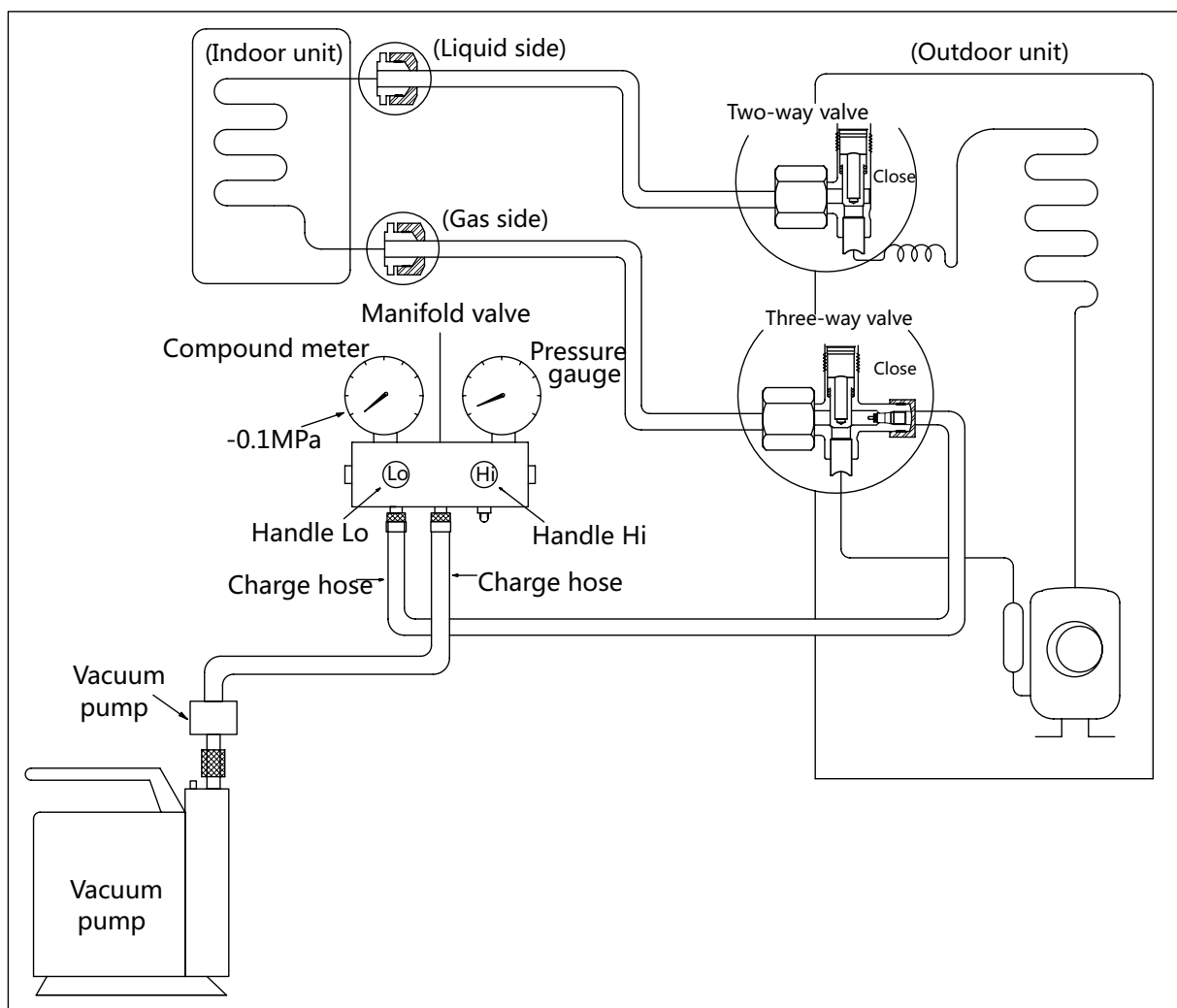

Procedure:

1. Tighten the flare nuts of the indoor and outdoor units, and confirm that both the 2- and 3-way valves are closed.
2. Connect the charge hose with the push pin of Handle Lo to the gas service port of the 3-way valve.
3. Connect the charge hose of Handle Hi connection to the vacuum pump.
4. Fully open the Handle Lo manifold valve.
5. Using the vacuum pump, evacuate the system for 30 minutes.
 - a. Check whether the compound meter indicates -0.1 MPa (14.5 Psi).
 - If the meter does not indicate -0.1 MPa (14.5 Psi) after 30 minutes, continue evacuating for an additional 20 minutes.
 - If the pressure does not achieve -0.1 MPa (14.5 Psi) after 50 minutes, check for leakage.
 - If the pressure successfully reaches -0.1 MPa (14.5 Psi), fully close the Handle Lo valve and cease vacuum pump operations.
 - b. Wait for 5 minutes then check whether the gauge needle moves after turning off the vacuum pump.
6. Loosen the flare nut of the 3-way valve for 6 or 7 seconds and then tighten the flare nut again.
 - c. Confirm the pressure display in the pressure indicator is slightly higher than the atmospheric pressure.
 - d. Remove the charge hose from the 3-way valve.
7. Fully open the 2- and 3-way valves and tighten the cap of the 3-way valve.

1.3.2 Outdoor Unit

Evacuation for the whole system

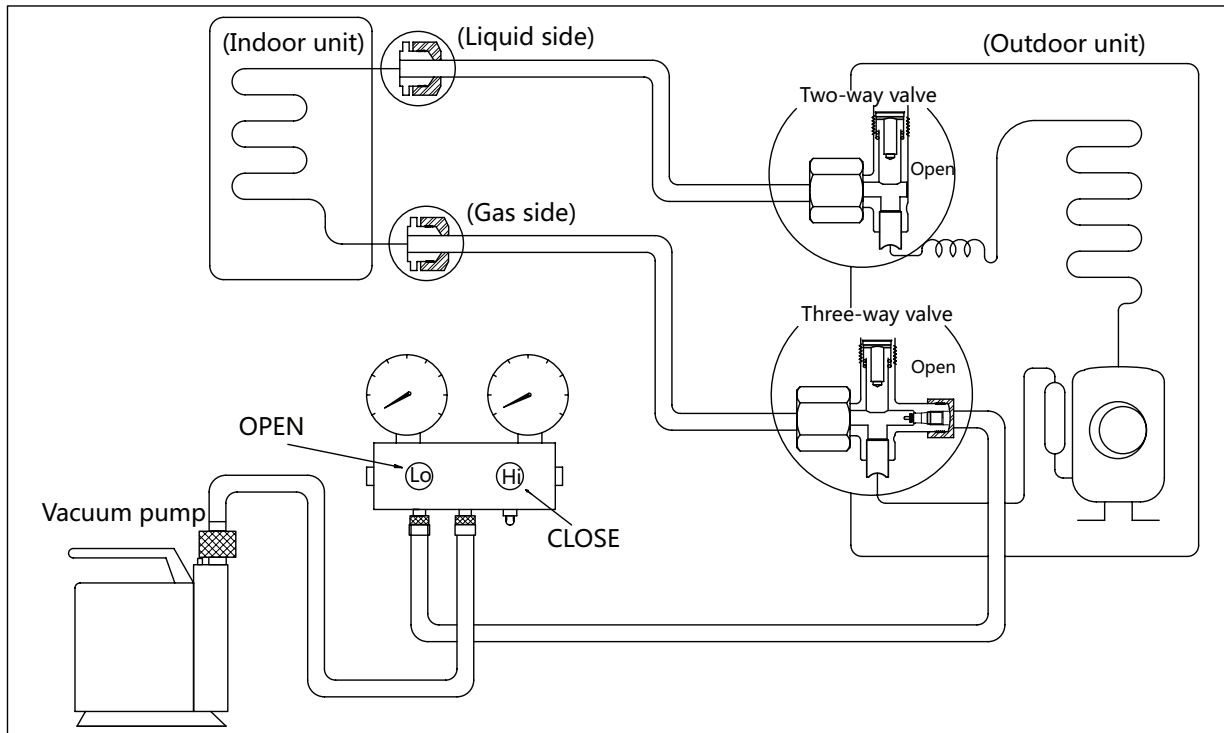

Procedure:

1. Confirm that the 2- and 3-way valves are opened.
2. Connect the vacuum pump to the 3-way valve's service port.
3. Evacuate the system for approximately one hour. Confirm that the compound meter indicates -0.1 MPa (14.5Psi).
4. Close the valve (Low side) on the charge set and turn off the vacuum pump.
5. Wait a period of five minutes then check whether the gauge needle moves after turning off the vacuum pump.
6. Disconnect the charge hose from the vacuum pump.

Refrigerant charging

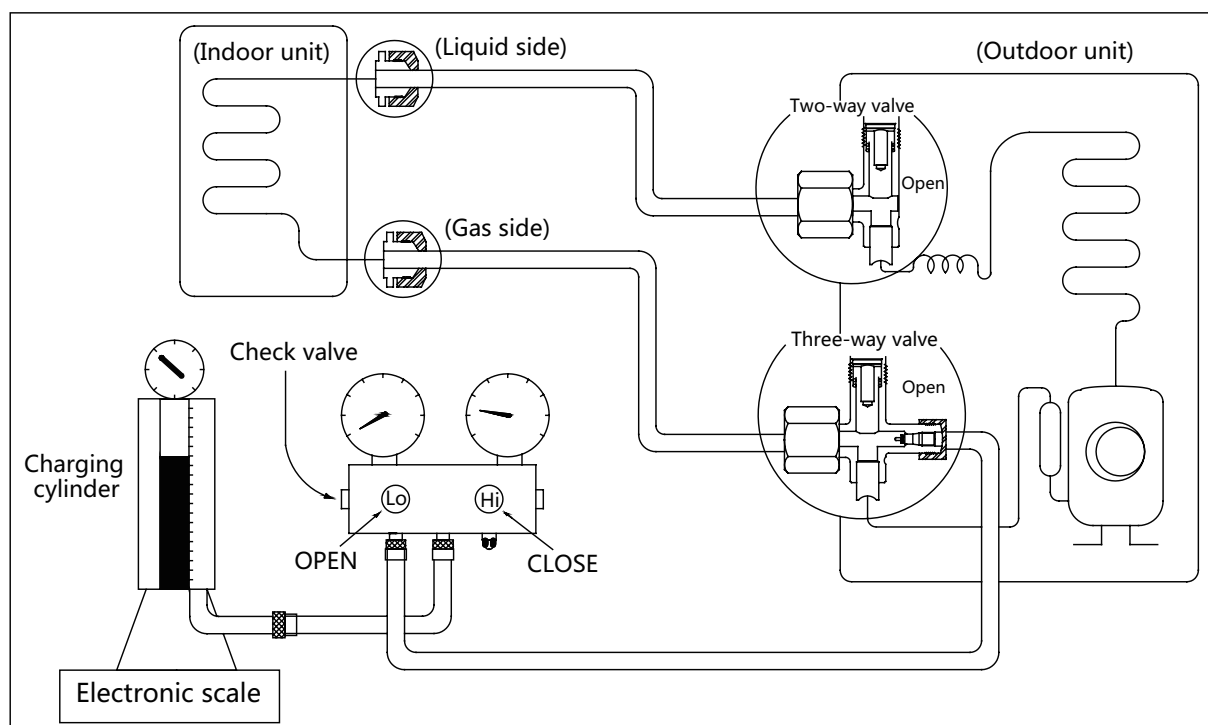

Procedure:

1. Connect the charge hose to the 3-way service port and then open the 2- and the 3-way valves.
2. Connect the charge hose to the valve at the bottom of the cylinder.
3. If the refrigerant is R410A, invert the cylinder to ensure a complete liquid charge.
4. Open the valve at the bottom of the cylinder and close the check valve on the charge set to purge the air.
5. Place the charging cylinder onto an electronic scale and record the starting weight.
6. Operate the air conditioner in cooling mode.
7. Open the valves (Low side) on the charge set and charge the system with liquid refrigerant.
8. When the electronic scale displays the correct weight (refer to the gauge and the pressure of the low side to confirm), disconnect the charge hose from the 3-way valve's service port immediately and turn off the air conditioner before disconnecting the hose.
9. Mount the valve stem caps and the service port.
10. Use a torque wrench to tighten the service port cap to a torque of 18 N.m.
11. Check for gas leakage.

Note: 1. Mechanical connectors used indoors shall comply with local regulations.

2. When mechanical connectors are reused indoors, sealing parts shall be renewed. When flared joints are reused indoors, the flare part shall be re-fabricated.

2. Disassembly

2.1 Indoor unit

1. Front Panel

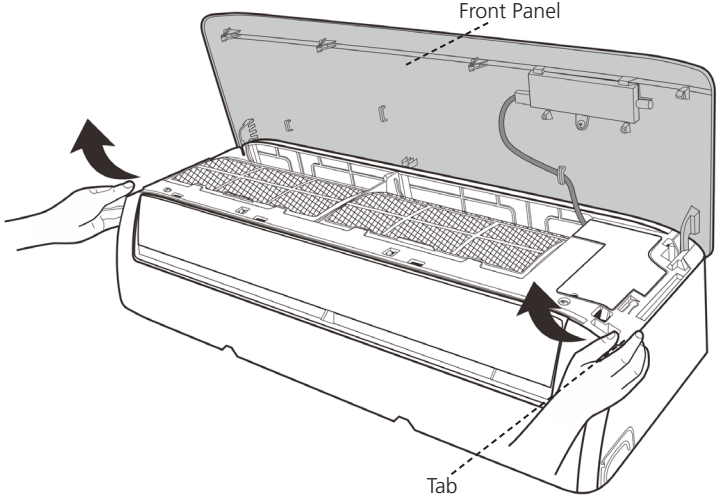
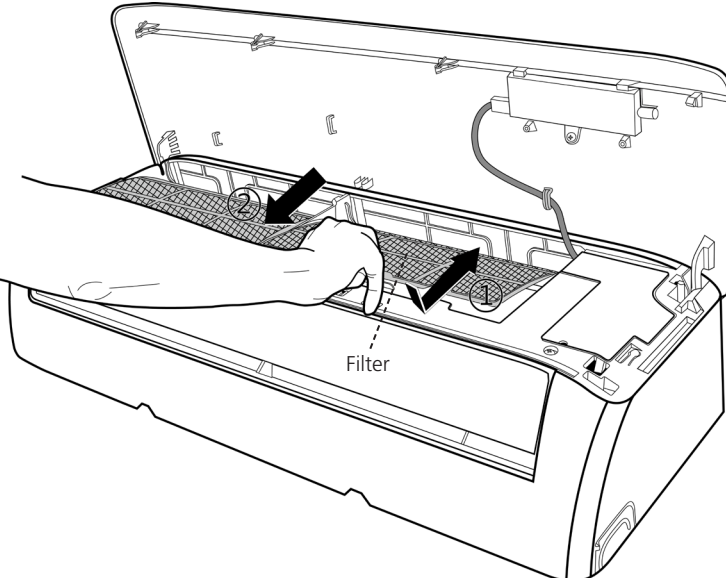
Procedure	Illustration
<p>1) Hold the front panel by the tabs on the both sides and lift it (see CJ_AB_INV_001).</p>	 <p style="text-align: center;">CJ_AB_INV_001</p>
<p>2) Push up the bottom of an air filter (step 1), and then pull it out downwards (step 2) (see CJ_AB_INV_002).</p>	 <p style="text-align: center;">CJ_AB_INV_002</p>

Note: This section is for reference only. Actual unit appearance may vary.

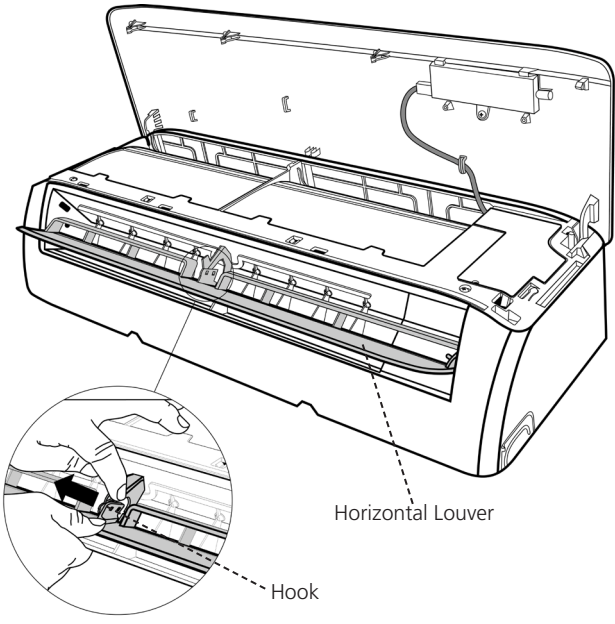
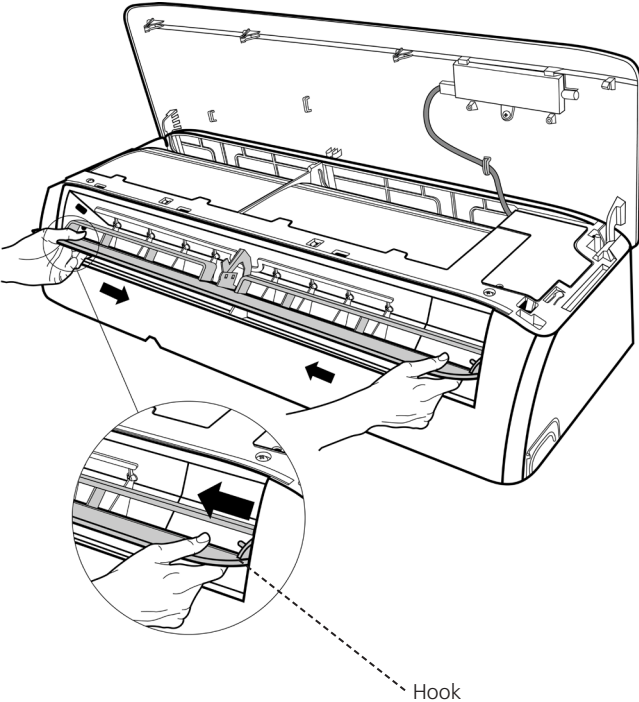
Procedure	Illustration
<p>3) Open the horizontal louver and push the hook towards left to open it (see CJ_AB_INV_003).</p>	 <p style="text-align: center;">CJ_AB_INV_003</p>
<p>4) Bend the horizontal louver lightly by both hands to loosen the hooks, then remove the horizontal louver (see CJ_AB_INV_004).</p>	 <p style="text-align: center;">CJ_AB_INV_004</p>

Note: This section is for reference only. Actual unit appearance may vary.

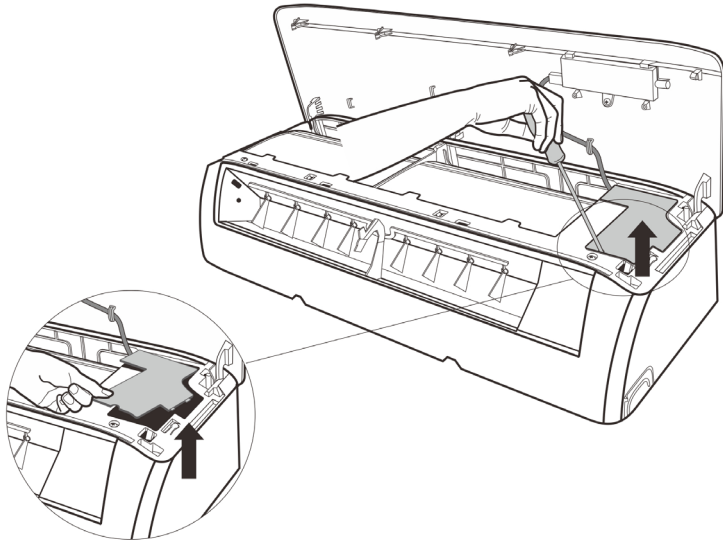
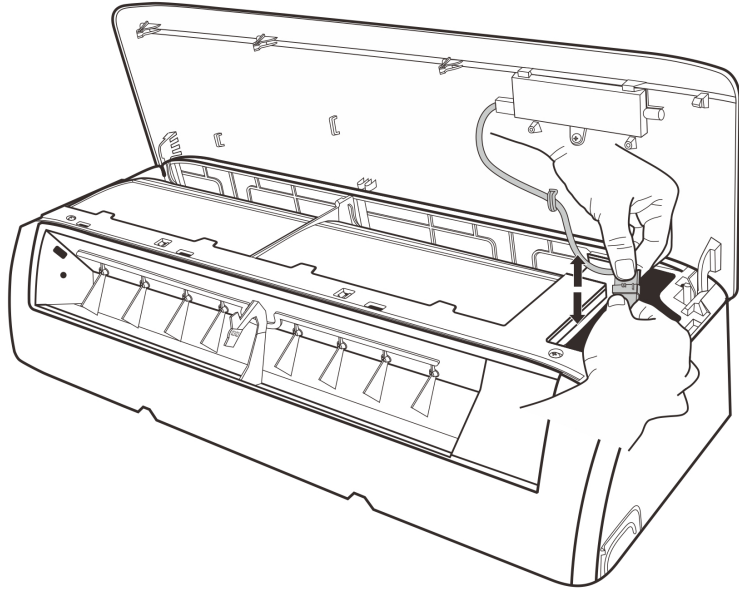
Procedure	Illustration
<p>5) Pry the electrical cover by a screw driver, and rotate it towards left, then remove it. (see CJ_AB_INV_005).</p>	 <p style="text-align: center;">CJ_AB_INV_005</p>
<p>6) Disconnect the connector for display board. (see CJ_AB_INV_006) .</p>	 <p style="text-align: center;">CJ_AB_INV_006</p>

Note: This section is for reference only. Actual unit appearance may vary.

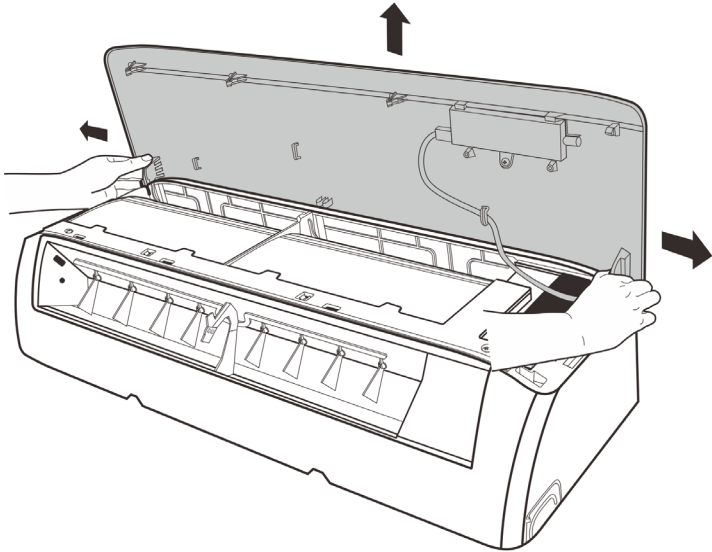
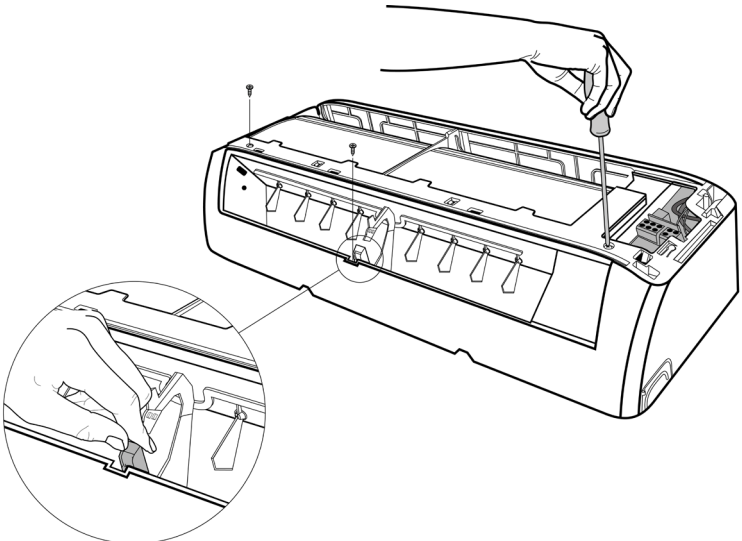
Procedure	Illustration
<p>7) Slid the front panel side to side to release each axis (see CJ_AB_INV_007)</p>	 <p style="text-align: center;">CJ_AB_INV_007</p>
<p>8) Open the screw cap and then remove the 3 screws (see CJ_AB_INV_008).</p>	 <p style="text-align: center;">CJ_AB_INV_008</p>

Note: This section is for reference only. Actual unit appearance may vary.

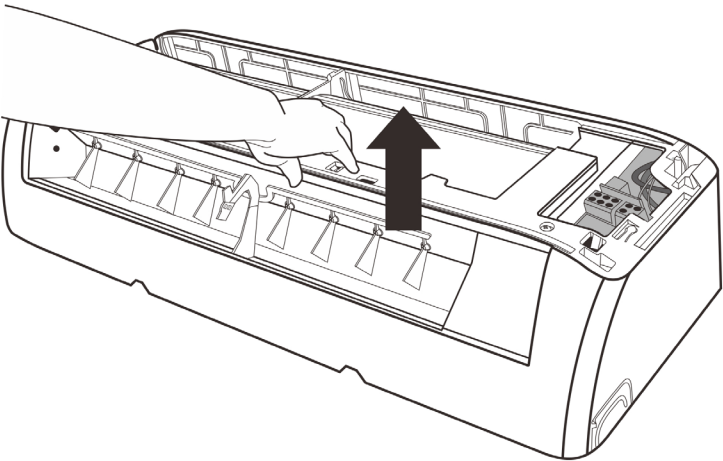
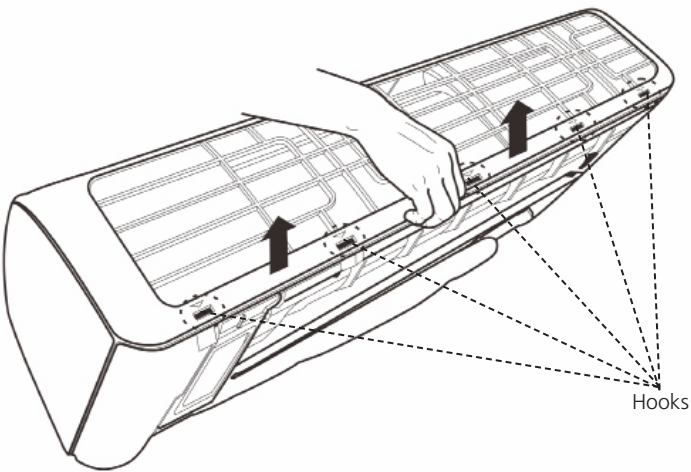
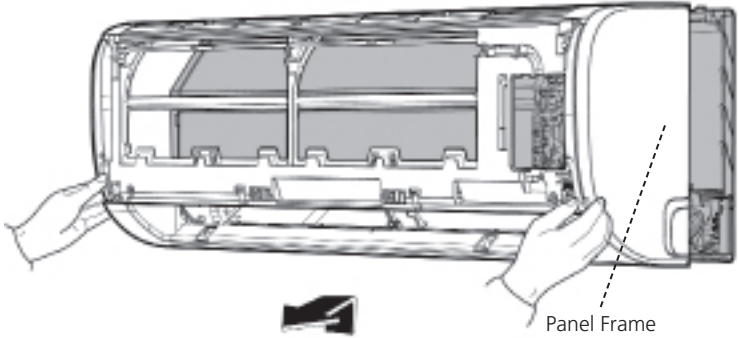
Procedure	Illustration
<p>9) Release the hooks with hands. (see CJ_AB_INV_009)</p>	 <p style="text-align: center;">CJ_AB_INV_009</p>
<p>10) Release the 5 hooks in the back (see CJ_AB_INV_010).</p>	 <p style="text-align: center;">CJ_AB_INV_010</p>
<p>11) Pull out the panel frame while pushing the hook through a clearance between the panel frame and the heat exchanger. (see CJ_AB_INV_011)</p>	 <p style="text-align: center;">CJ_AB_INV_011</p>

Note: This section is for reference only. Actual unit appearance may vary.

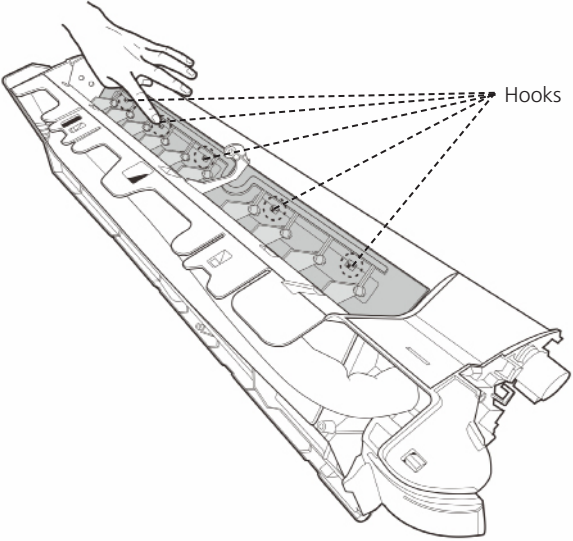
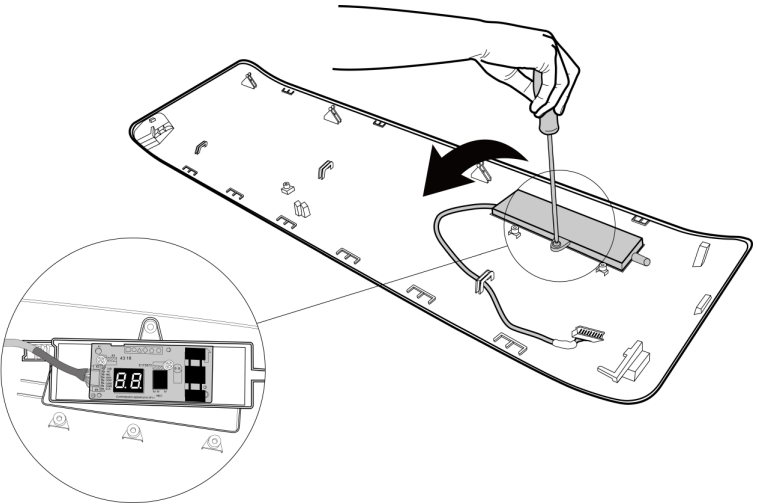
Procedure	Illustration
<p>12) Release the 5 hooks of the vertical blades, then pull the vertical blades rightward and remove it (see CJ_AB_INV_012).</p>	 <p style="text-align: center;">CJ_AB_INV_012</p>
<p>13) Remove 1 screw of the display board. (see CJ_AB_INV_013).</p> <p>14) Rotate the display board in the direction shown in the right picture. (see CJ_AB_INV_013).</p>	 <p style="text-align: center;">CJ_AB_INV_013</p>

Note: This section is for reference only. Actual unit appearance may vary.

2. Electrical parts (Antistatic gloves must be worn.)

Note: Remove the front panel (refer to 1. Front panel) before disassembling electrical parts.

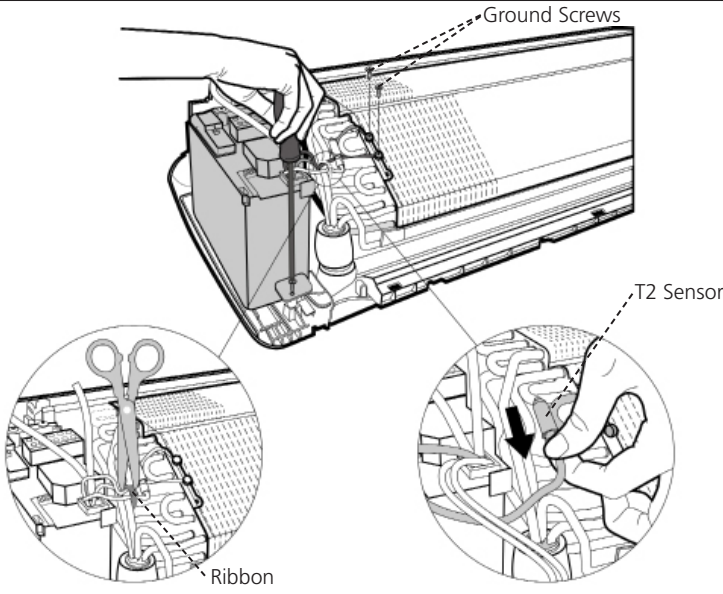
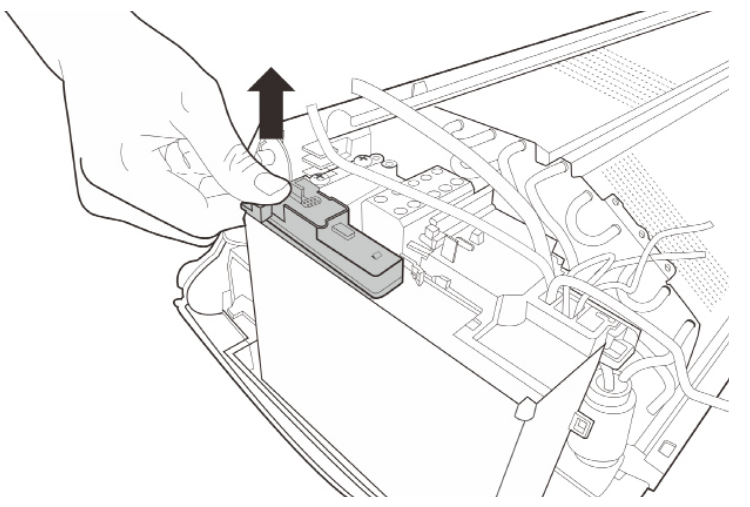
Procedure	Illustration
<p>1) Cut the ribbon by a shear, then pull out the coil temperature sensor (T2) (see CJ_AB_INV_014).</p> <p>2) Remove one fixing screw of the electronic control box and two screws used for the ground connection (see CJ_AB_INV_014).</p>	 <p style="text-align: center;">CJ_AB_INV_014</p>
<p>3) An upward force is maintained until the cover of electronic control box is removed (see CJ_AB_INV_015).</p>	 <p style="text-align: center;">CJ_AB_INV_015</p>

Note: This section is for reference only. Actual unit appearance may vary.

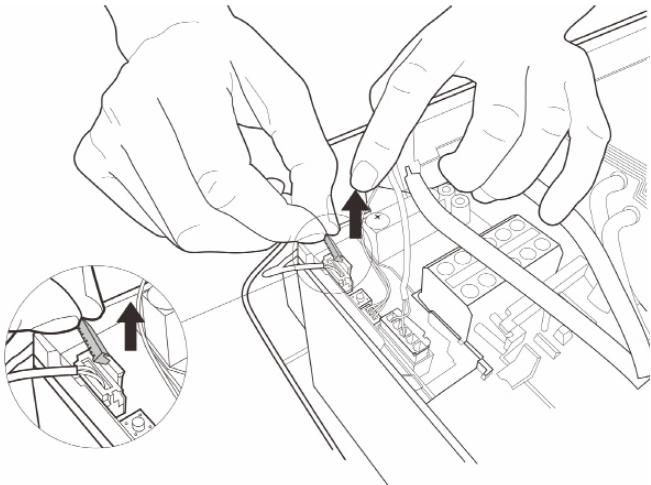
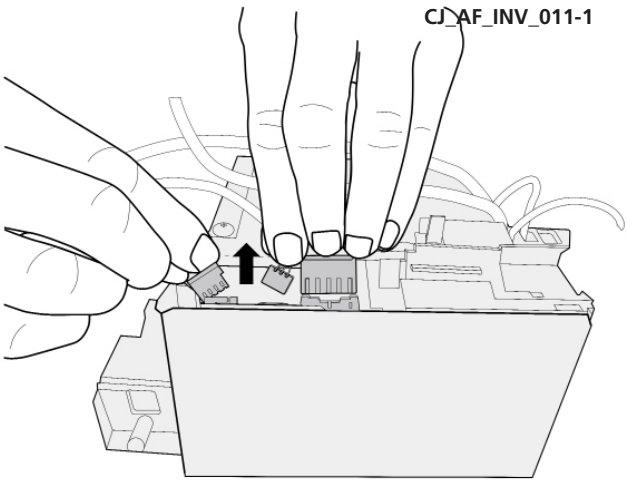
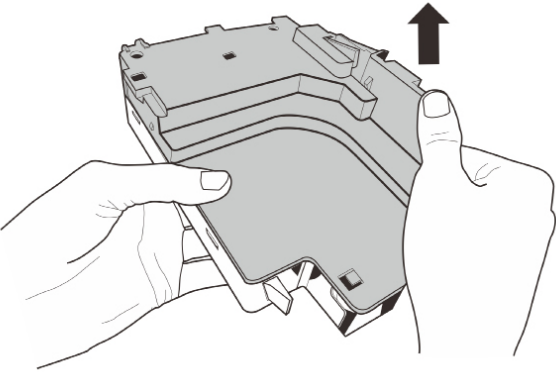
Procedure	Illustration
<p>4) Remove the fixed devices of the connectors (see CJ_AB_INV_016).</p>	 <p style="text-align: center;">CJ_AB_INV_016</p>
<p>5) Disconnect the connectors of fan motor, the step motor and the T2 sensor (see CJ_AB_INV_017).</p>	 <p style="text-align: center;">CJ_AB_INV_017</p>
<p>6) Open the left side plate of electronic control box (see CJ_AB_INV_018).</p>	 <p style="text-align: center;">CJ_AB_INV_018</p>

Note: This section is for reference only. Actual unit appearance may vary.

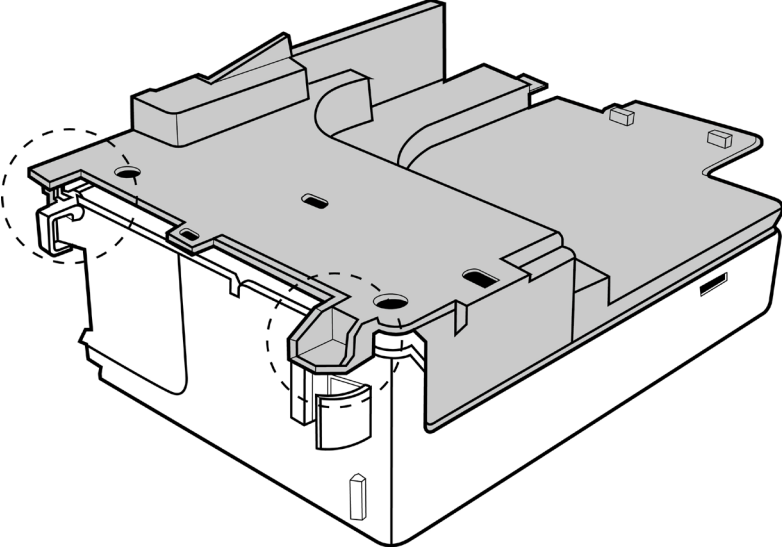
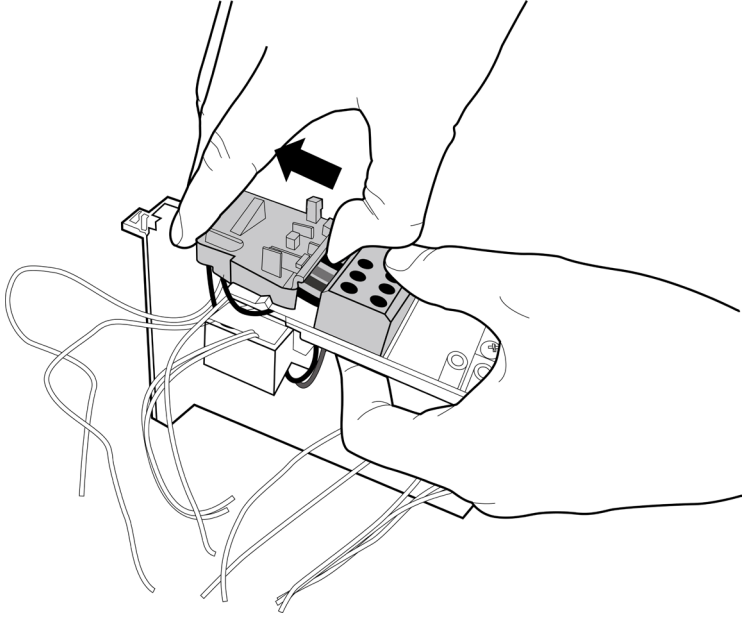
Procedure	Illustration
<p>7) Open the two clips on the front of the electric box. (see CJ_AB_INV_019)</p>	 <p style="text-align: center;">CJ_AB_INV_019</p>
<p>8) Open the upper cover plate of electronic control box (see CJ_AB_INV_020).</p>	 <p style="text-align: center;">CJ_AB_INV_020</p>

Note: This section is for reference only. Actual unit appearance may vary.

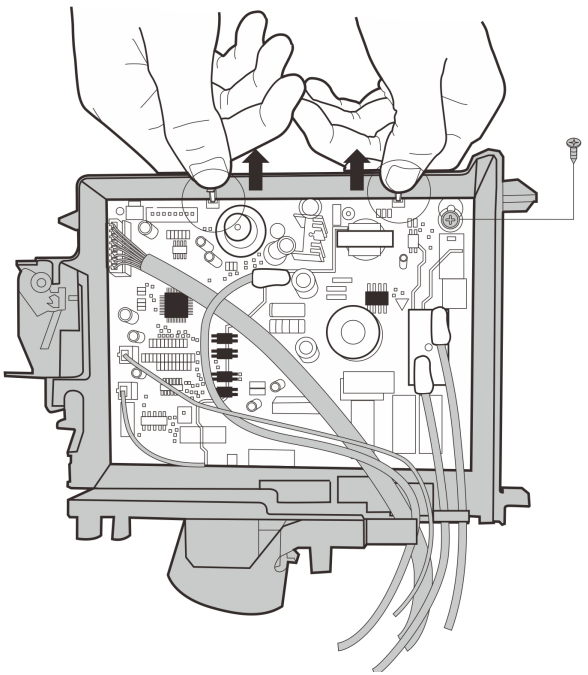
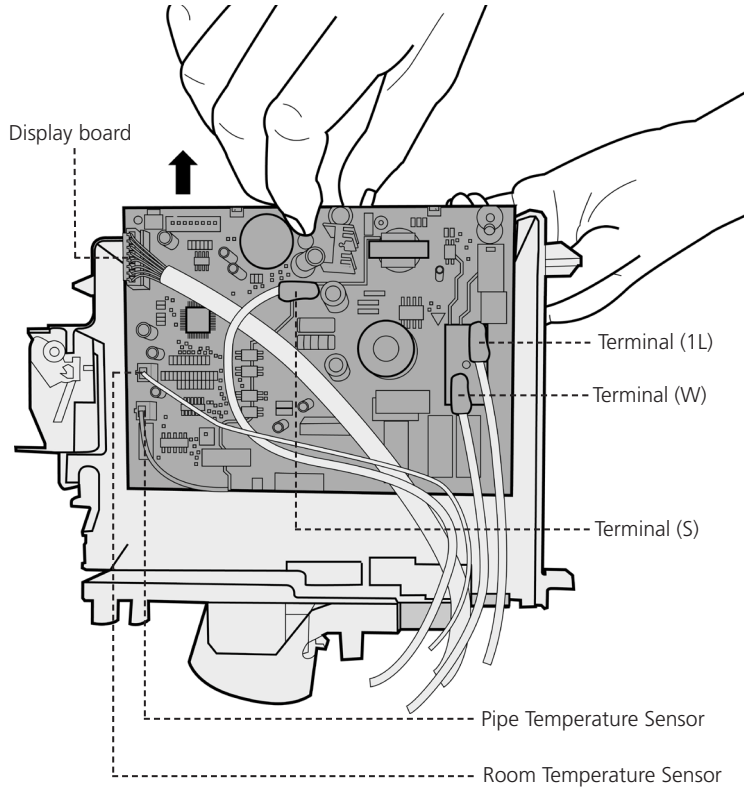
Procedure	Illustration
<p>9) Remove 1 screw and open the 2 clips along the direction indicated in right image (see CJ_AB_INV_021).</p>	 <p style="text-align: center;">CJ_AB_INV_021</p>
<p>10) Pull out the electrical main board along the direction indicated in right image to remove it (see CJ_AB_INV_022).</p>	 <p style="text-align: center;">CJ_AB_INV_022</p>

Note: This section is for reference only. Actual unit appearance may vary.

3. Evaporator

Note: Remove the front panel and electrical parts (refer to 1. Front panel and 2. Electrical parts) before disassembling evaporator.

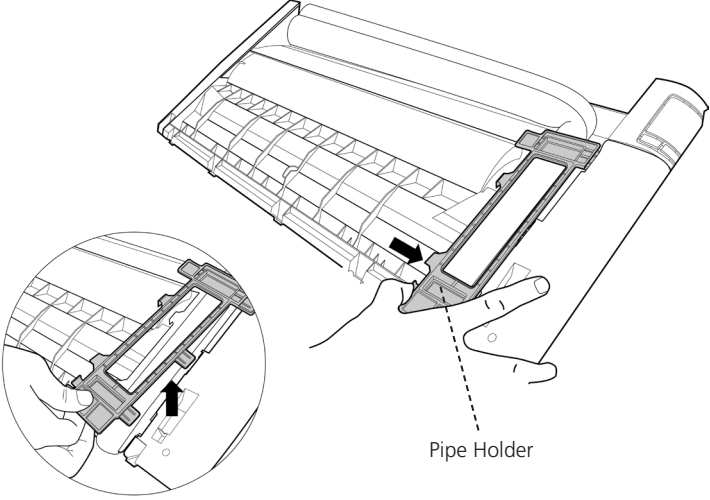
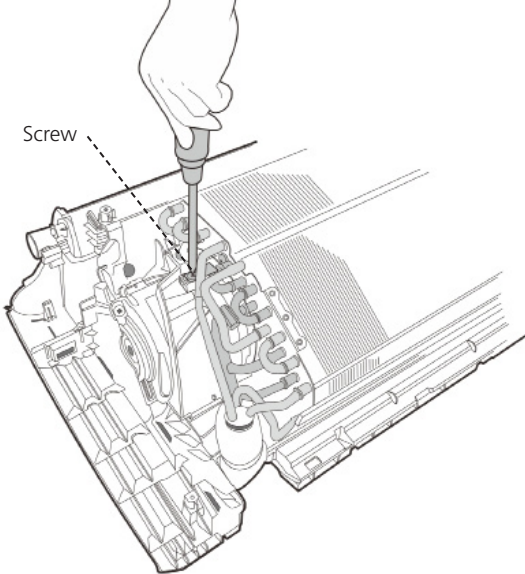
Procedure	Illustration
1) Disassemble the pipe holder located at the rear of the unit (see CJ_AB_INV_023).	 <p style="text-align: center;">CJ_AB_INV_023</p>
2) Remove the 1 screws on the evaporator located at the fixed plate (see CJ_AB_INV_024).	 <p style="text-align: center;">CJ_AB_INV_024</p>

Note: This section is for reference only. Actual unit appearance may vary.

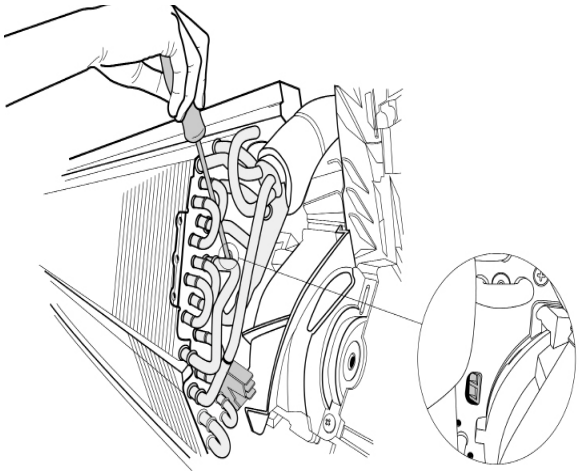
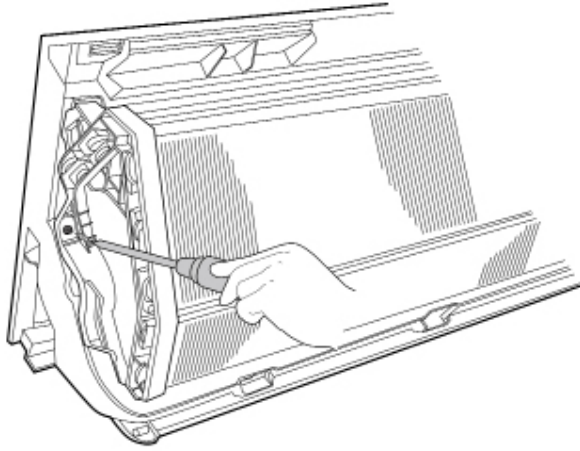
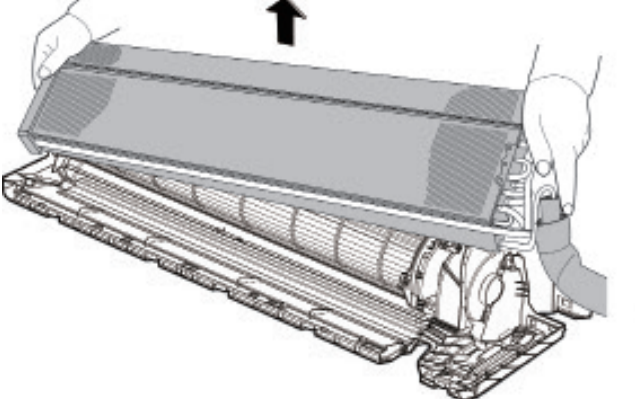
Procedure	Illustration
<p>3) Release the hook on the evaporator (see CJ_AB_INV_025).</p>	 <p style="text-align: center;">CJ_AB_INV_025</p>
<p>4) Remove the one screw on the evaporator located at the fixed plate (see CJ_AB_INV_026).</p>	 <p style="text-align: center;">CJ_AB_INV_026</p>
<p>5) Pull out the evaporator (see CJ_AB_INV_027).</p>	 <p style="text-align: center;">CJ_AB_INV_027</p>

Note: This section is for reference only. Actual unit appearance may vary.

4. Fan motor and fan

Note: Remove the front panel, electrical parts and evaporator (refer to 1. Front panel, 2. Electrical parts, and 3. Evaporator). before disassembling fan motor and fan.

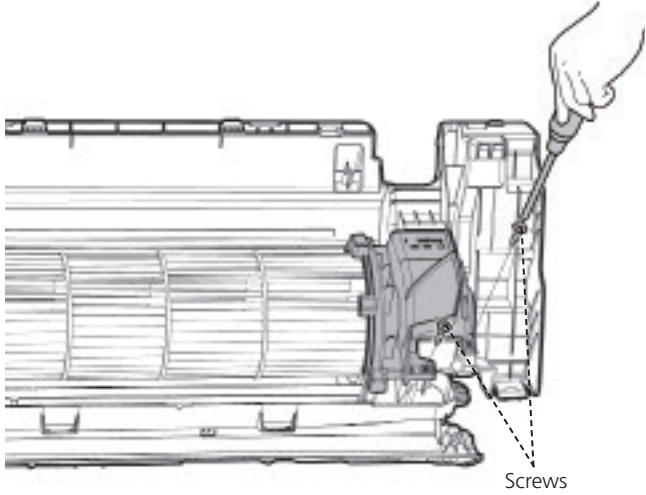
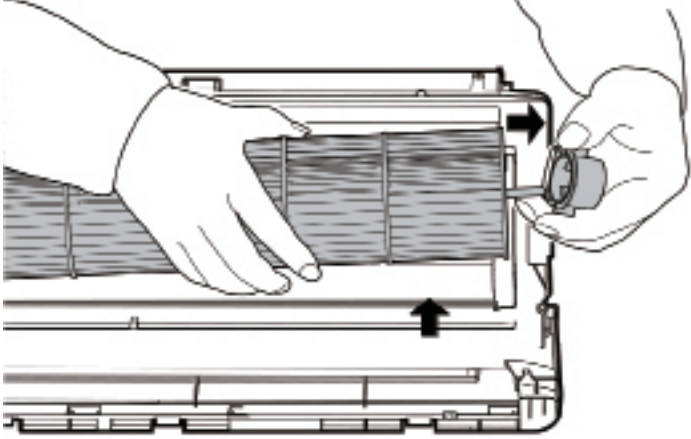
Procedure	Illustration
1) Remove the two screws and remove the fixing board of the fan motor (see CJ_AB_INV_028).	 <p data-bbox="938 1041 1141 1075">CJ_AB_INV_028</p>
2) Remove the bearing sleeve (see CJ_AB_INV_029).	 <p data-bbox="938 1747 1141 1780">CJ_AB_INV_029</p>

Note: This section is for reference only. Actual unit appearance may vary.

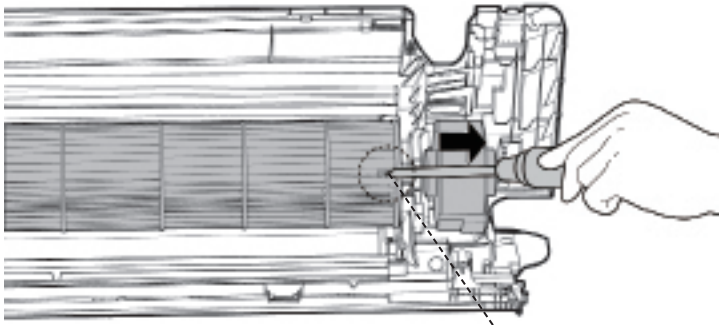
Procedure	Illustration
<p>3) Remove the fixing screw (see CJ_AB_INV_030).</p> <p>4) Pull out the fan motor and fan assembly from the side.</p>	 <p data-bbox="938 775 1142 808">CJ_AB_INV_030</p> <p data-bbox="1203 748 1321 775">Fixing Screw</p>

Note: This section is for reference only. Actual unit appearance may vary.

5. Step motor

Note: Remove the front panel and electrical parts (refer to 1. Front panel, 2. Electrical parts) before disassembling step motor.

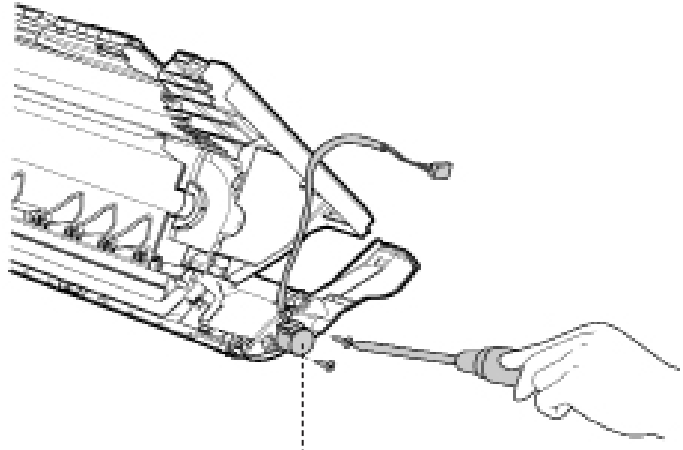
Procedure	Illustration
1) Remove the two screws, then remove the stepping motor (see CJ_AB_INV_031).	 <p data-bbox="932 909 1078 936">Stepping Motor</p> <p data-bbox="938 1005 1139 1032">CJ_AB_INV_031</p>

Note: This section is for reference only. Actual unit appearance may vary.

6. Drain Hose

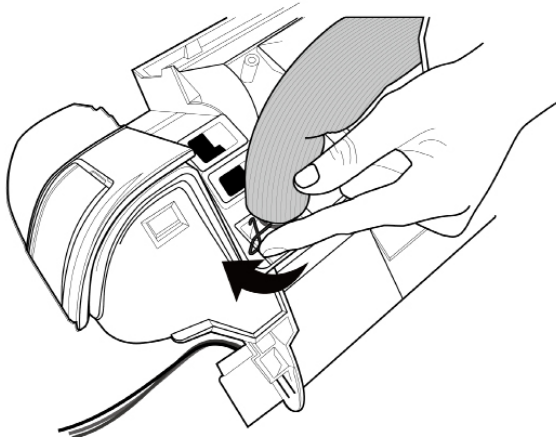
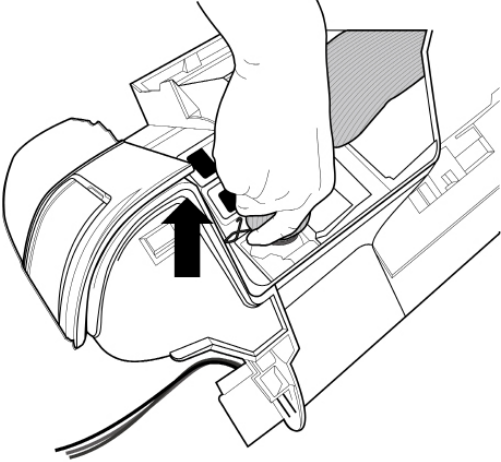
Procedure	Illustration
1) Rotate the fixed wire clockwise indicated in right image (see CJ_AB_INV_032).	 <p data-bbox="938 922 1141 958">CJ_AB_INV_032</p>
2) Pull up the drain hose to remove it (see CJ_AB_INV_033).	 <p data-bbox="938 1482 1141 1518">CJ_AB_INV_033</p>

Note: This section is for reference only. Actual unit appearance may vary.

2.2 Outdoor unit

1. Panel Plate

9K and 12K

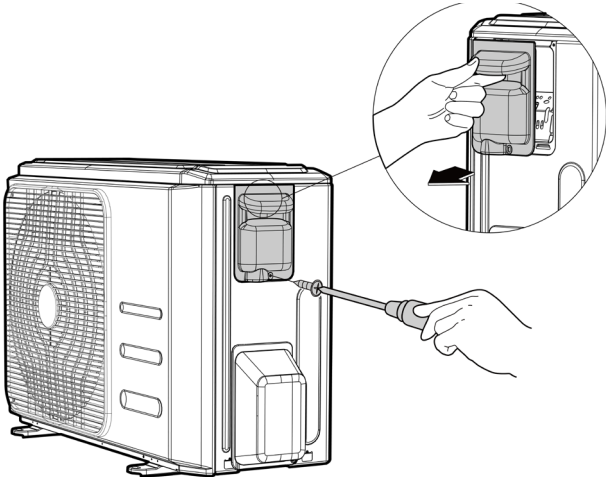
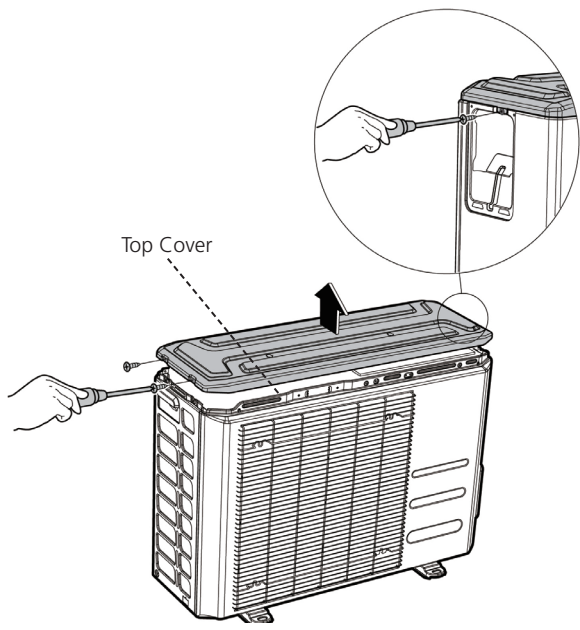
Procedure	Illustration
<p>1) Turn off the air conditioner and the power breaker.</p> <p>2) Remove the screws of the big handle and then remove the big handle (3 screws) (see CJ_BA30_INV_001).</p>	 <p>For US models (3 screws)</p> <p>CJ_BA30_INV_001</p>
<p>3) Remove the screws of the top cover and then remove the top cover (3 screws). One of the screws is located underneath the big handle (see CJ_BA30_INV_002).</p>	 <p>Top Cover</p> <p>CJ_BA30_INV_002</p>

Note: This section is for reference only. Actual unit appearance may vary.

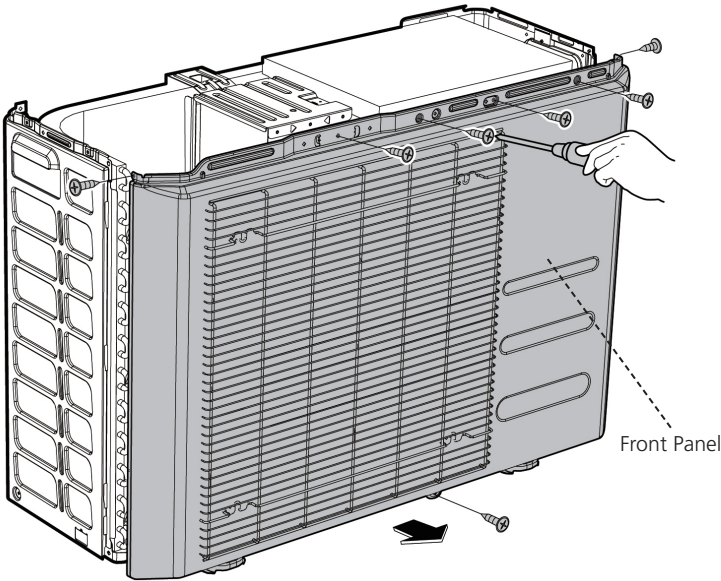
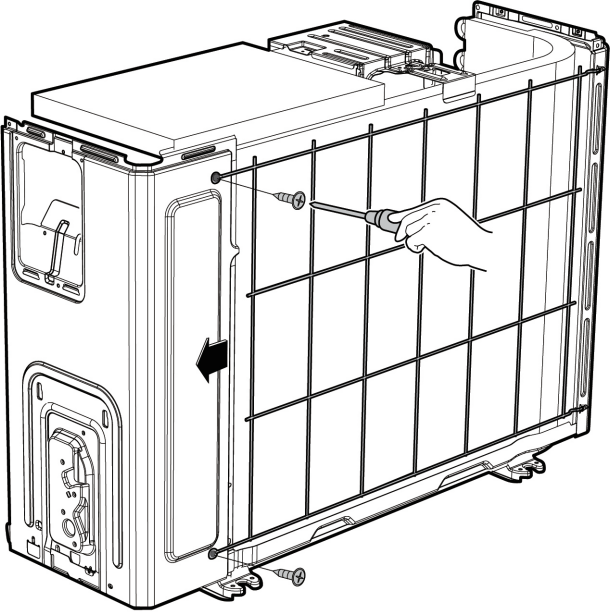
Procedure	Illustration
<p>4) Remove the screws of the front panel and then remove the front panel (7 screws) (see CJ_BA30_INV_003).</p>	 <p>CJ_BA30_INV_003</p>
<p>5) Remove the screws of the rear net and then remove the rear net (2 screws) (see CJ_BA30_INV_004).</p>	 <p>CJ_BA30_INV_004</p>

Note: This section is for reference only. Actual unit appearance may vary.

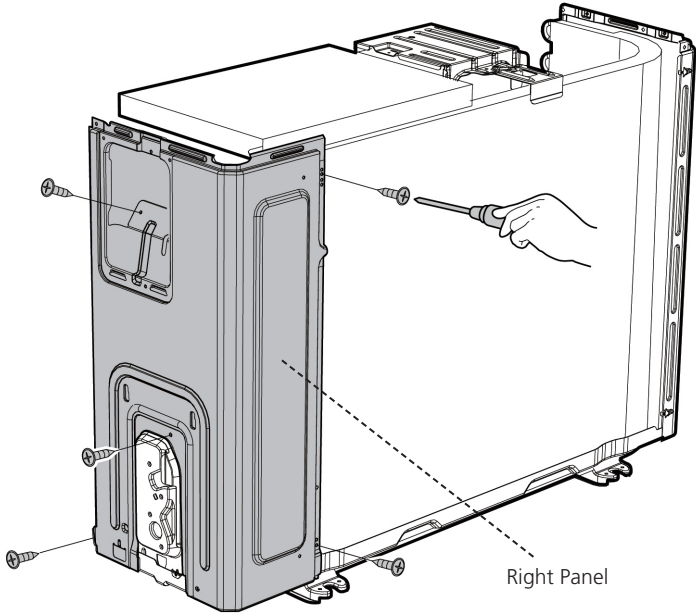
Procedure	Illustration
<p>6) Remove the screws of the right panel and then remove the right panel (5 screws) (see CJ_BA30_INV_005).</p>	 <p data-bbox="900 1021 1134 1055">CJ_BA30_INV_005</p>

Note: This section is for reference only. Actual unit appearance may vary.

Procedure	Illustration
<p>1) Turn off the air conditioner and the power breaker.</p> <p>2) Remove the screws of the big handle and then remove the big handle (3 screws) (see CJ_B30_INV_001).</p> <p>3) Remove the screws of the top cover and then remove the top cover (3 screws). One of the screws is located underneath the big handle (see CJ_B30_INV_002).</p>	<p>For US models (3 screws)</p> <p>Top Cover</p> <p>CJ_B30_INV_001</p> <p>CJ_B30_INV_002</p>

Note: This section is for reference only. Actual unit appearance may vary.

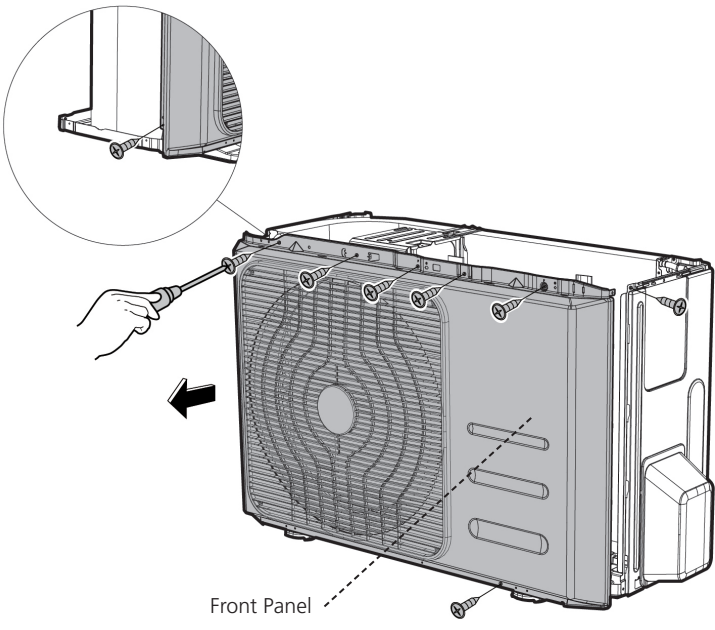
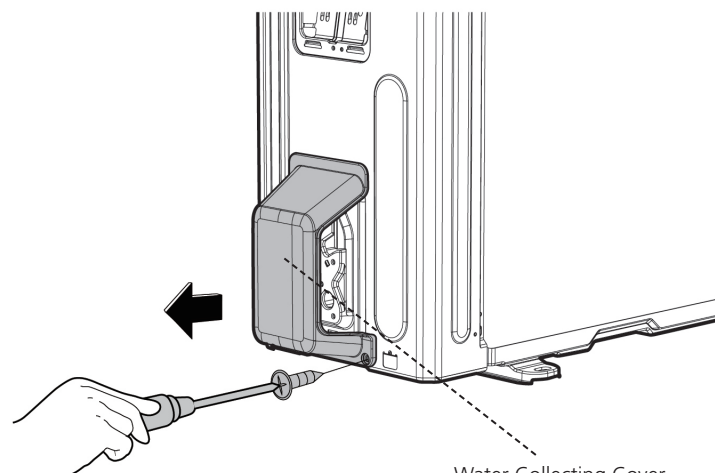
Procedure	Illustration
<p>4) Remove the screws of the front panel and then remove the front panel (8 screws) (see CJ_B30_INV_003).</p>	 <p>CJ_B30_INV_003</p>
<p>5) Remove the screws of water collecting cover and then remove the water collecting cover (1 screw) (see CJ_B30_INV_004).</p>	 <p>CJ_B30_INV_004</p>

Note: This section is for reference only. Actual unit appearance may vary.

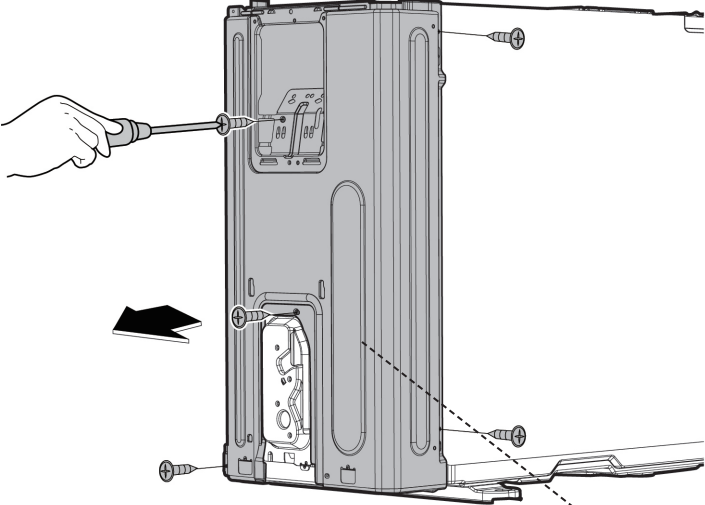
Procedure	Illustration
6) Remove the screws of the right panel and then remove the right panel (5 screws) (see CJ_B30_INV_005).	 <p data-bbox="906 945 1123 976">CJ_B30_INV_005</p> <p data-bbox="1238 900 1343 922">Right Panel</p>

Note: This section is for reference only. Actual unit appearance may vary.

24K

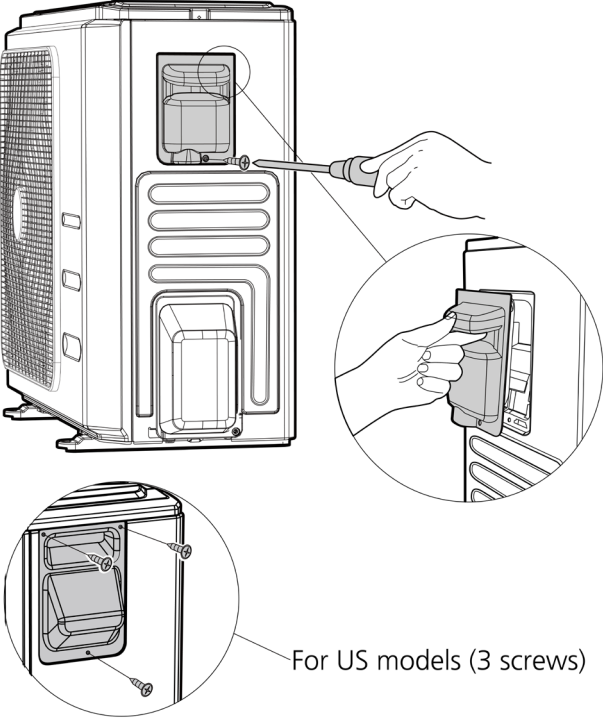
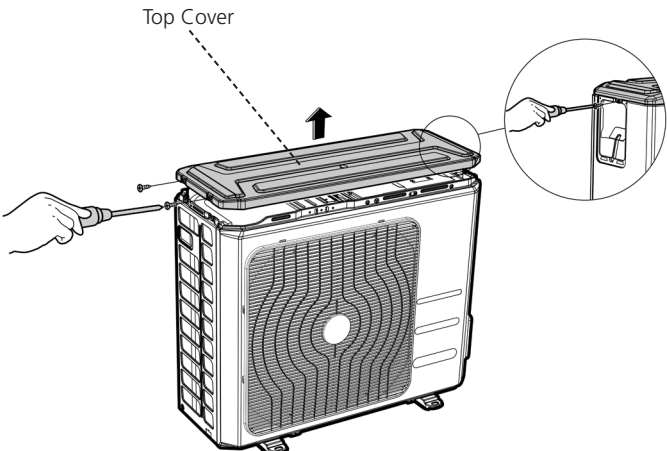
Procedure	Illustration
<p>1) Turn off the air conditioner and the power breaker.</p> <p>2) Remove the screws of the big handle and then remove the big handle (3 screws) (see CJ_CA30_INV_001).</p>	 <p>For US models (3 screws)</p> <p>CJ_CA30_INV_001</p>
<p>3) Remove the screws of the top cover and then remove the top cover (3 screws). One of the screws is located underneath the big handle (see CJ_CA30_INV_002).</p>	 <p>Top Cover</p> <p>CJ_CA30_INV_002</p>

Note: This section is for reference only. Actual unit appearance may vary.

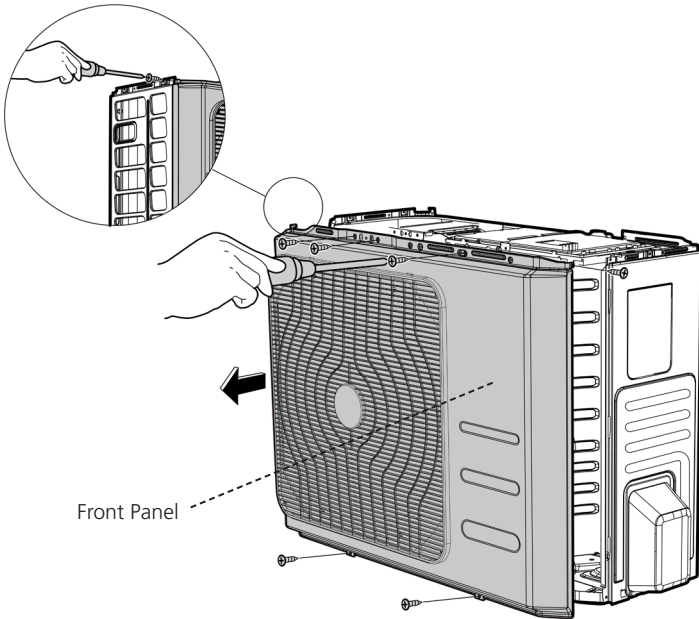
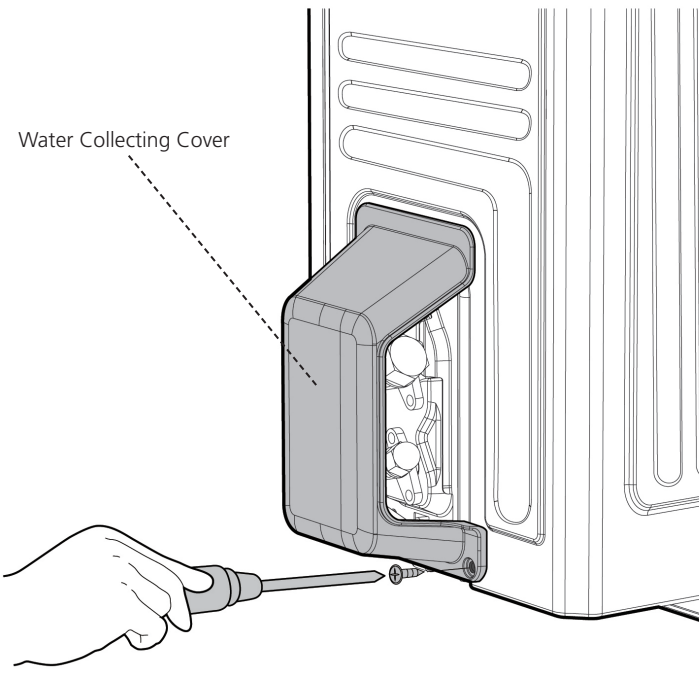
Procedure	Illustration
<p>4) Remove the screws of the front panel and then remove the front panel (7 screws) (see CJ_CA30_INV_003).</p>	 <p>CJ_CA30_INV_003</p>
<p>5) Remove the screws of water collecting cover and then remove the water collecting cover (1 screw) (see CJ_CA30_INV_004).</p>	 <p>CJ_CA30_INV_004</p>

Note: This section is for reference only. Actual unit appearance may vary.

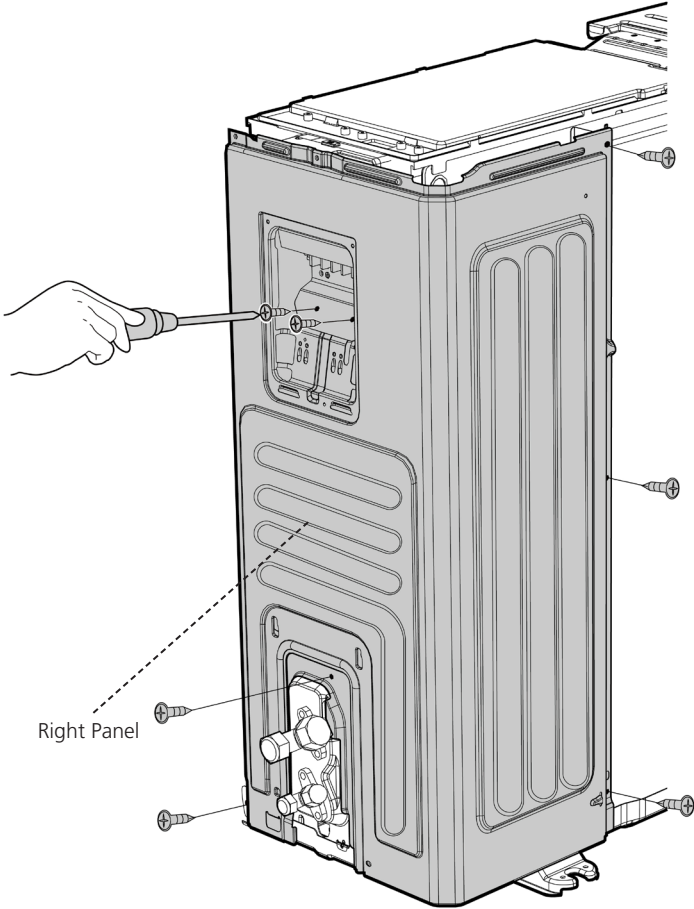
Procedure	Illustration
<p>6) Remove the screws of the right panel and then remove the right panel (6 screws) (see CJ_CA30_INV_005).</p>	 <p>The illustration shows a hand using a screwdriver to remove screws from the right panel of a unit. The unit is shown in a three-quarter view, with the right panel being the focus. A dashed line points to the right panel, which is labeled "Right Panel". The unit has a control panel on the left side and a large panel on the right side. The right panel is being removed, and the screws are shown being unscrewed. The unit is labeled "CJ_CA30_INV_005" at the bottom.</p>

Note: This section is for reference only. Actual unit appearance may vary.

2. Fan disassembly (Antistatic gloves must be worn when you disassemble the electronic box.)

Note: Remove the panel plate and (refer to 1. Panel plate) before disassembling fan.

9K 12K 18K

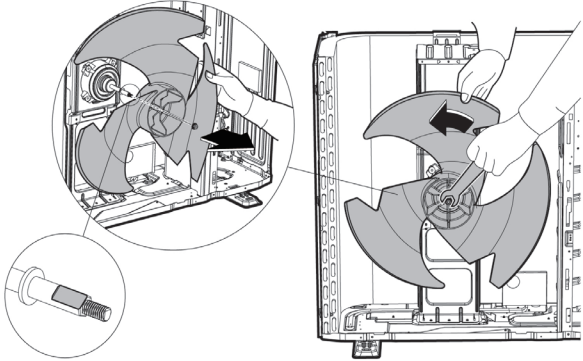
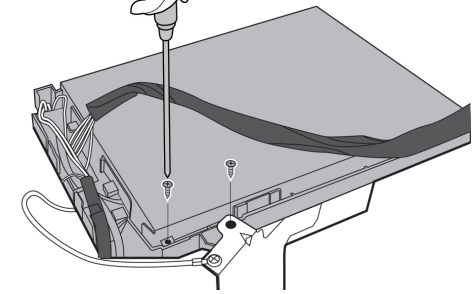
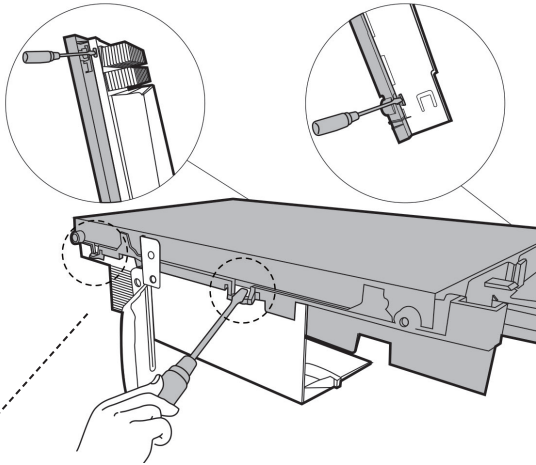
Procedure	Illustration
<p>1) Remove the nut securing the fan with a spanner (see CJ_ODU_INV_001).</p> <p>2) Remove the fan.</p>	 <p>CJ_ODU_INV_001</p>
<p>3) Remove the screws of the top cover. (2 screws) (see CJ_ODU_INV_002).</p>	 <p>D-cut</p> <p>CJ_ODU_INV_002</p>
<p>4) Unfix the hooks and then open the electronic control box cover (4 hooks) (see CJ_ODU_INV_003).</p>	 <p>Hook</p> <p>CJ_ODU_INV_003</p>

Note: This section is for reference only. Actual unit appearance may vary.

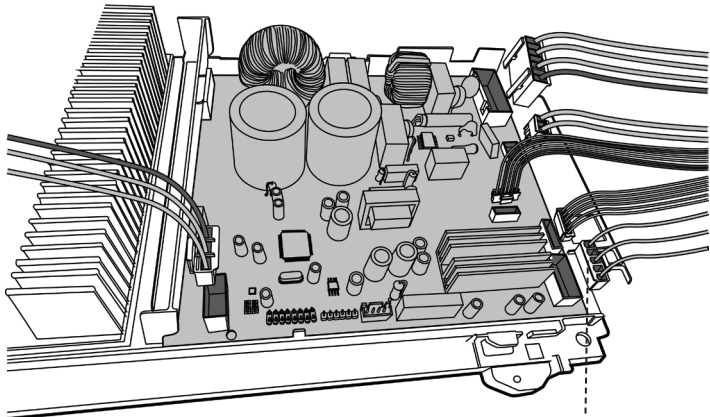
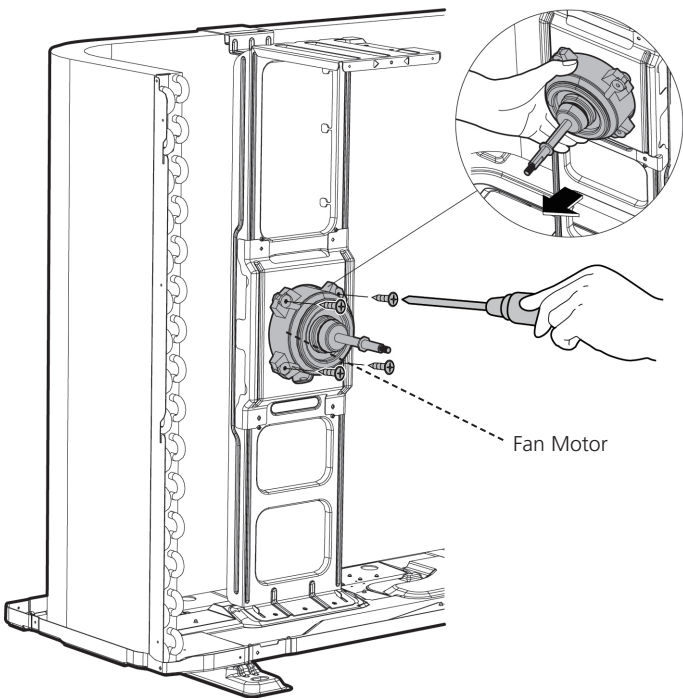
Procedure	Illustration
<p>5) Disconnect the connector for fan motor from the electronic control board (see CJ_ODU_INV_004).</p>	 <p style="text-align: right;">Fan Motor CJ_ODU_INV_004</p>
<p>6) Remove the fixing screws of the fan motor (4 screws) (see CJ_ODU_INV_005).</p> <p>7) Remove the fan motor.</p>	 <p style="text-align: right;">Fan Motor</p> <p style="text-align: center;">CJ_ODU_INV_005</p>

Note: This section is for reference only. Actual unit appearance may vary.

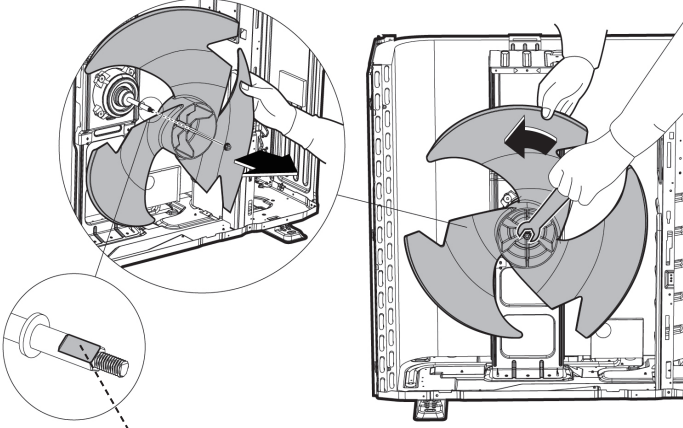
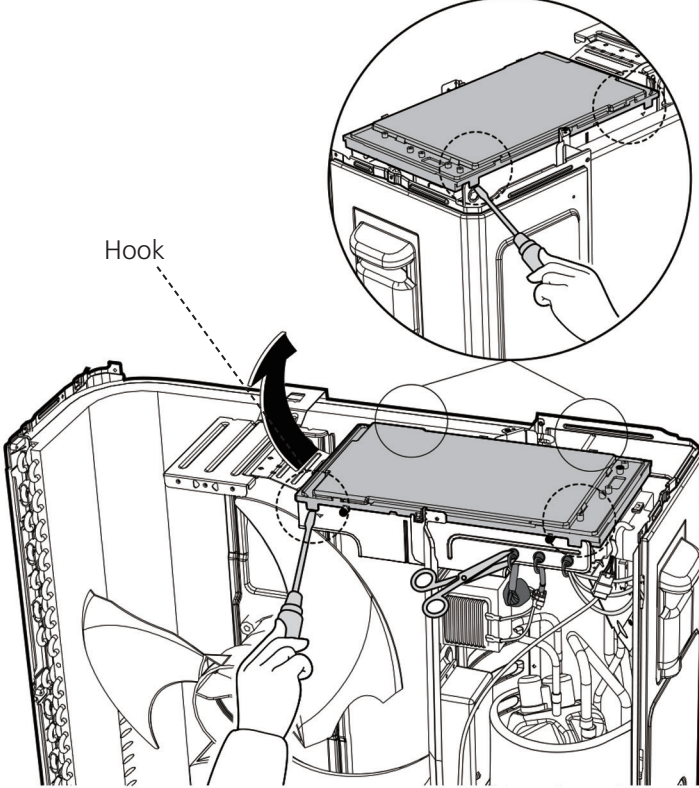
Procedure	Illustration
<p>1) Remove the nut securing the fan with a spanner (see CJ_ODU_INV_006).</p> <p>2) Remove the fan.</p>	 <p style="text-align: center;">D-cut</p> <p style="text-align: center;">CJ_ODU_INV_006</p>
<p>3) Unfix the hooks and then open the electronic control box cover (4 hooks) (see CJ_ODU_INV_007).</p>	 <p style="text-align: center;">Hook</p> <p style="text-align: center;">CJ_ODU_INV_007</p>

Note: This section is for reference only. Actual unit appearance may vary.

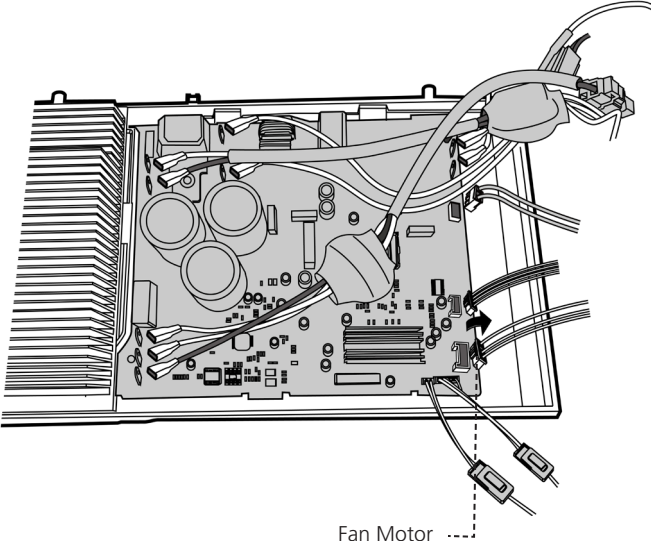
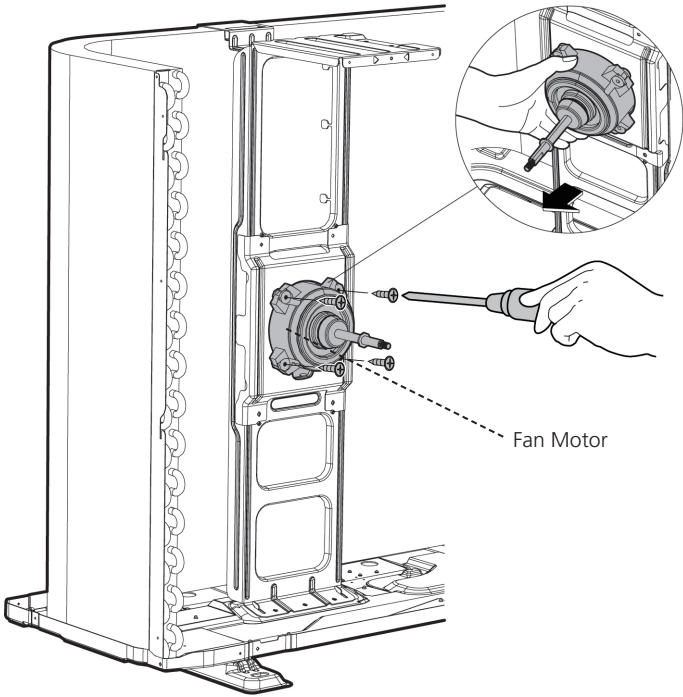
Procedure	Illustration
<p>4) Disconnect the connector for fan motor from the electronic control board (see CJ_ODU_INV_008).</p>	 <p style="text-align: center;">Fan Motor</p> <p style="text-align: center;">CJ_ODU_INV_008</p>
<p>5) Remove the fixing screws of the fan motor (4 screws) (see CJ_ODU_INV_009).</p> <p>6) Remove the fan motor.</p>	 <p style="text-align: right;">Fan Motor</p> <p style="text-align: center;">CJ_ODU_INV_009</p>

Note: This section is for reference only. Actual unit appearance may vary.

3. Electrical parts (Antistatic gloves must be worn.)

Note: Remove the panel plate and fan assembly (refer to 1. Panel plate and 2. Fan assembly) before disassembling electrical parts.

9K 12K

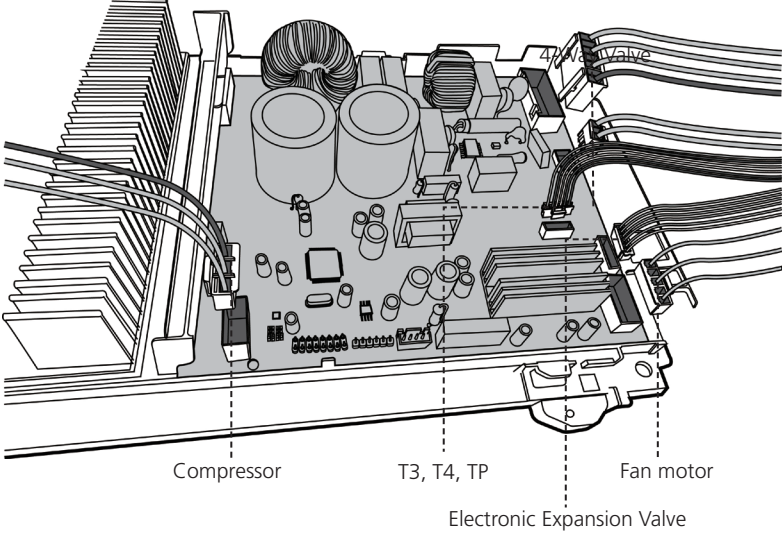
Procedure	Illustration
<ol style="list-style-type: none">1) Remove the connector for the compressor (see CJ_ODU_INV_010).2) Pull out the two blue wires connected with the four way valve (CJ_ODU_INV_010).3) Pull out connectors of the condenser coil temp. sensor(T3), outdoor ambient temp. sensor(T4) and discharge temp. sensor(TP) (CJ_ODU_INV_010).4) Disconnect the electronic expansion valve wire (CJ_ODU_INV_010).5) Then remove the electronic control box (see CJ_ODU_INV_010).	 <p data-bbox="903 1223 1134 1256">CJ_ODU_INV_010</p>

Note: This section is for reference only. Actual unit appearance may vary.

18K 24K

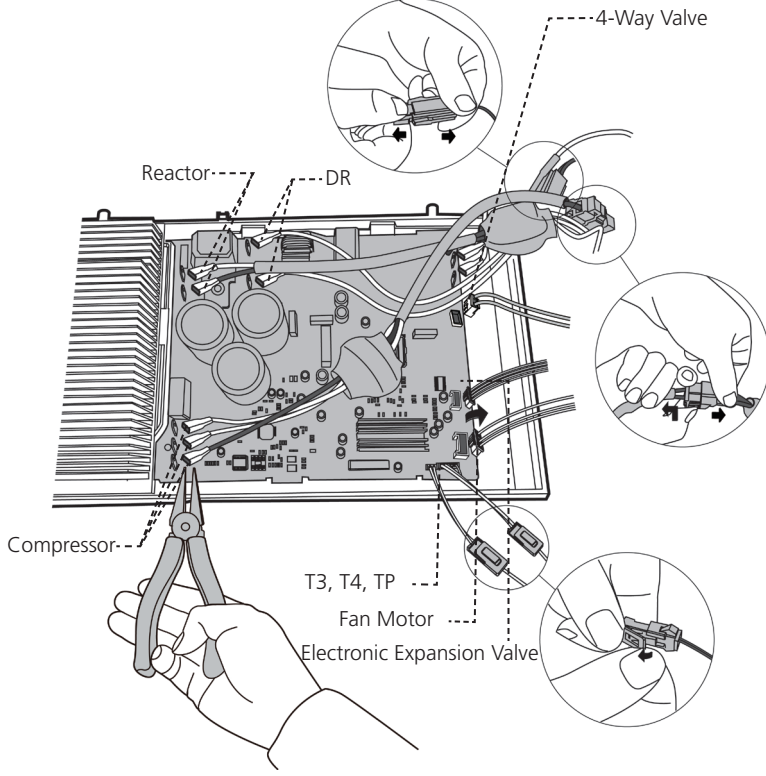
Procedure	Illustration
<ol style="list-style-type: none">1) Remove the connector for the compressor (see CJ_ODU_INV_011).2) Pull out the two blue wires connected with the four way valve (see CJ_ODU_INV_011).3) Pull out connectors of the condenser coil temp. sensor(T3), outdoor ambient temp. sensor(T4) and discharge temp. sensor(T5) (see CJ_ODU_INV_011).4) Disconnect the electronic expansion valve wire (see Fig CJ_ODU_INV_011).5) Remove the connector for electric heaters (see Fig CJ_ODU_INV_011).6) Remove the connector for the DR and reactor (see Fig CJ_ODU_INV_011).7) Then remove the electronic control box (see Fig CJ_ODU_INV_011).	 <p style="text-align: center;">CJ_ODU_INV_011</p>

Note: This section is for reference only. Actual unit appearance may vary.

4. Sound blanket

⚠ WARNING: Recover refrigerant from the refrigerant circuit before remove the compressor.

Note: Remove the panel plate, electrical parts, and fan assembly (refer to 1. Panel plate, 2. Electrical parts, and 3. Fan assembly) before disassembling sound blanket.

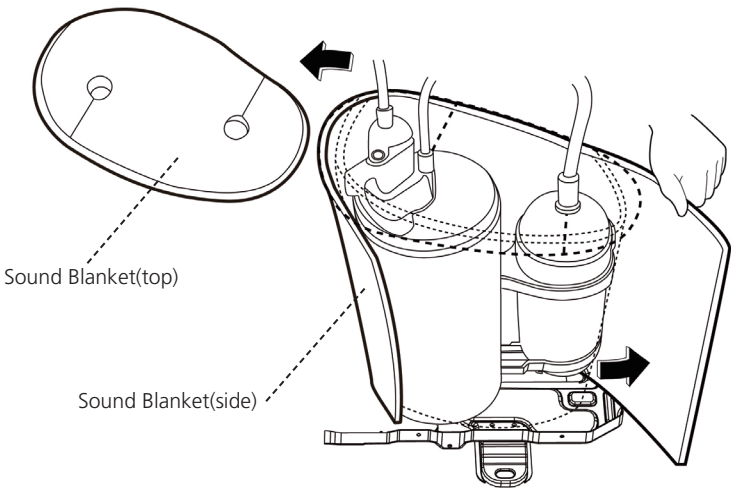
Procedure	Illustration
1) Remove the sound blanket (side and top) (see CJ_ODU_INV_012).	 <p data-bbox="901 1064 1133 1097">CJ_ODU_INV_012</p>

Note: This section is for reference only. Actual unit appearance may vary.

5. Four-way valve (For heat pump models)

⚠ WARNING: Recover refrigerant from the refrigerant circuit before remove the four-way valve.

Note: Remove the panel plate, electrical parts, and fan assembly (refer to 1. Panel plate, 2. Electrical parts, and 3. Fan assembly) before disassembling four-way valve.

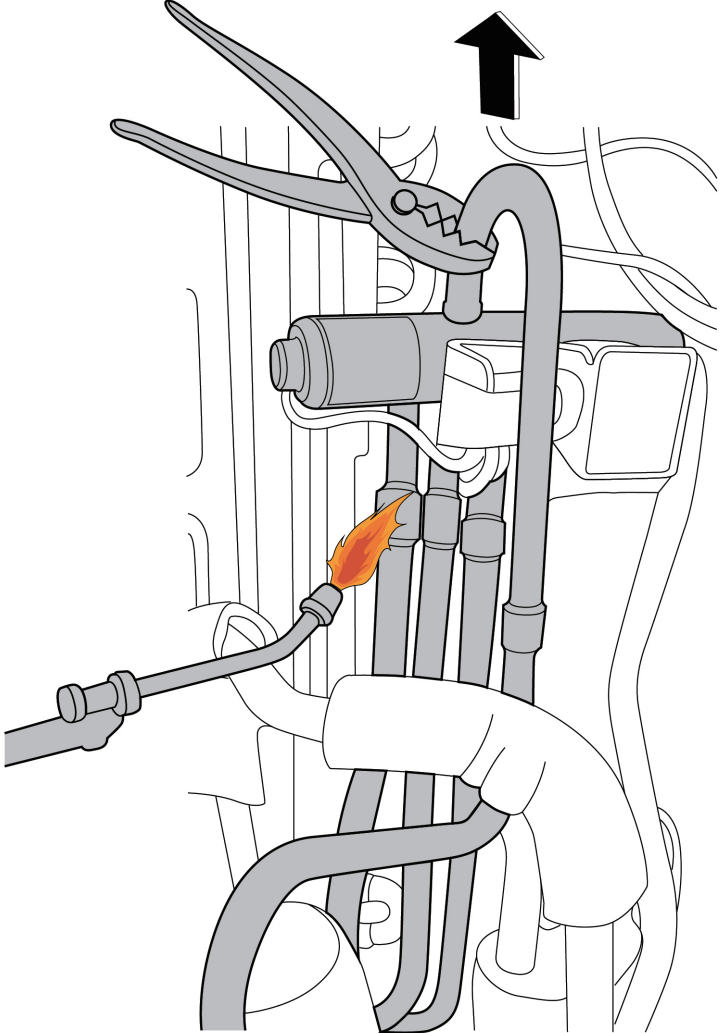
Procedure	Illustration
<ol style="list-style-type: none">1) Heat up the brazed parts and then detach the the four-way valve and the pipe (see CJ_ODU_INV_013).2) Remove the four-way valve assembly with pliers.	 <p data-bbox="927 1653 1155 1688">CJ_ODU_INV_013</p>

Note: This section is for reference only. Actual unit appearance may vary.

6. Compressor

⚠ WARNING: Recover refrigerant from the refrigerant circuit before remove the compressor.

Note: Remove the panel plate, electrical parts, and fan assembly (refer to 1. Panel plate, 2. Electrical parts, and 3. Fan assembly) before disassembling compressor.

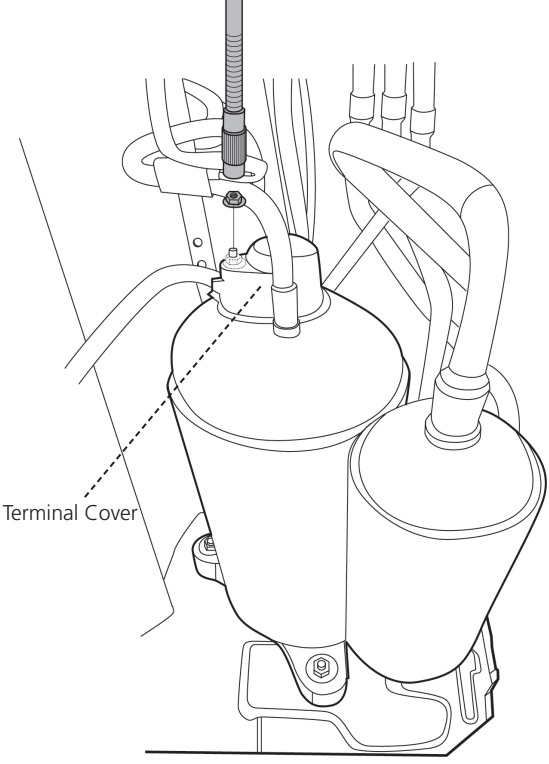
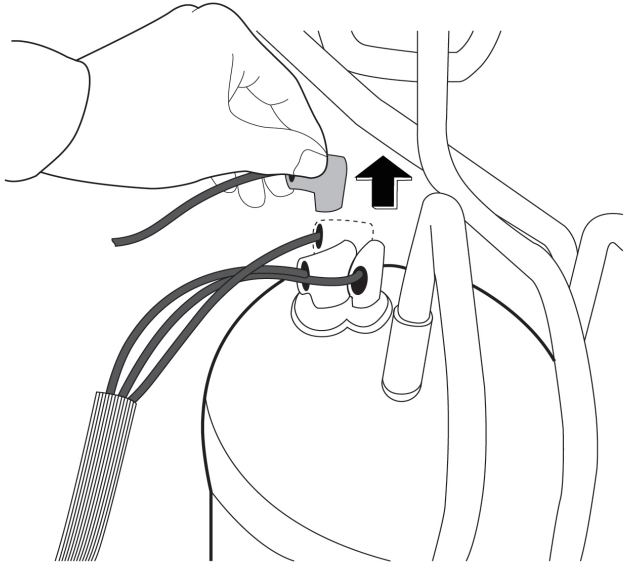
Procedure	Illustration
<p>1) Remove the flange nut of terminal cover and remove the terminal cover (see CJ_ODU_INV_014).</p>	 <p>The diagram shows a top-down view of the compressor assembly. A dashed line points to a terminal cover on the left side of the unit. The cover is a cylindrical component with a flange at the top. A hand is shown using a tool to remove the flange nut. The label 'Terminal Cover' is placed next to the dashed line. Below the diagram is the reference code 'CJ_ODU_INV_014'.</p>
<p>2) Disconnect the connectors (see CJ_ODU_INV_015).</p>	 <p>The diagram shows a close-up of the electrical connectors on the compressor. A hand is shown pulling a connector away from the unit. An upward-pointing arrow indicates the direction of removal. Below the diagram is the reference code 'CJ_ODU_INV_015'.</p>

Note: This section is for reference only. Actual unit appearance may vary.

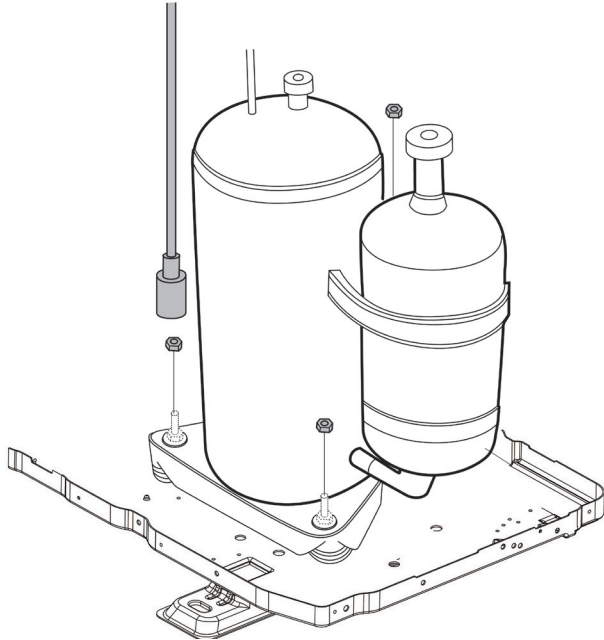
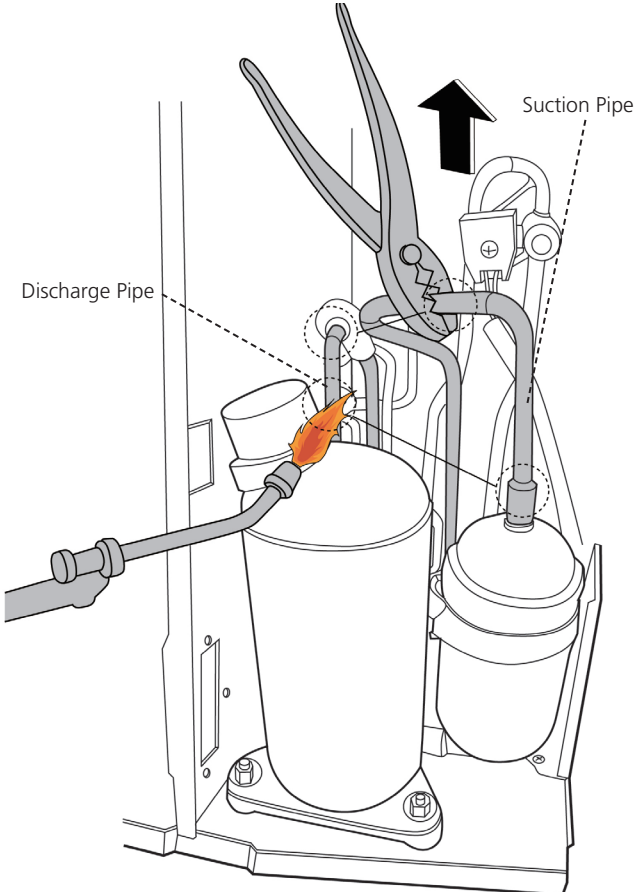
Procedure	Illustration
<p>3) Remove the hex nuts and washers securing the compressor, located on the bottom plate (see CJ_ODU_INV_016).</p>	 <p style="text-align: center;">CJ_ODU_INV_016</p>
<p>4) Heat up the brazed parts and then remove the the discharge pipe and the suction pipe (see CJ_ODU_INV_017).</p> <p>5) Lift the compressor from the base pan assembly with pliers.</p>	 <p style="text-align: center;">CJ_ODU_INV_017</p>

Note: This section is for reference only. Actual unit appearance may vary.

Troubleshooting

Contents

1.	Safety Caution	62
2.	General Troubleshooting	63
3.	Error Diagnosis and Troubleshooting Without Error Code.....	64
	3.1 Remote maintenance.....	64
	3.2 Field maintenance	65
4.	Quick Maintenance by Error Code.....	70
5.	Troubleshooting by Error Code.....	71
	5.1 Common Check Procedures.....	71
	5.2 E0/F4 (EEPROM parameter error)	73
	5.3 E1 (Indoor and outdoor unit communication error)	74
	5.4 E2 (Zero crossing detection error diagnosis and solution)	76
	5.5 E3/F5 (Fan speed has been out of control diagnosis and solution)	77
	5.6 E4/E5/F1/F2/F3 (Open circuit or short circuit of temperature sensor diagnosis and solution).....	80
	5.7 EC (Refrigerant Leakage Detection diagnosis and solution)	81
	5.8 F0(Overload current protection diagnosis and solution).....	82
	5.9 P0(IPM malfunction or IGBT over-strong current protection diagnosis and solution)	83



Contents

5.10	P1(Over voltage or too low voltage protection diagnosis and solution).....	84
5.11	P2(High temperature protection of IPM module diagnosis and solution).....	85
5.12	P4(Inverter compressor drive error diagnosis and solution)	86

1. Safety Caution

WARNING

Electricity remains in capacitors even when the power supply is off.
Ensure the capacitors are fully discharged before troubleshooting.

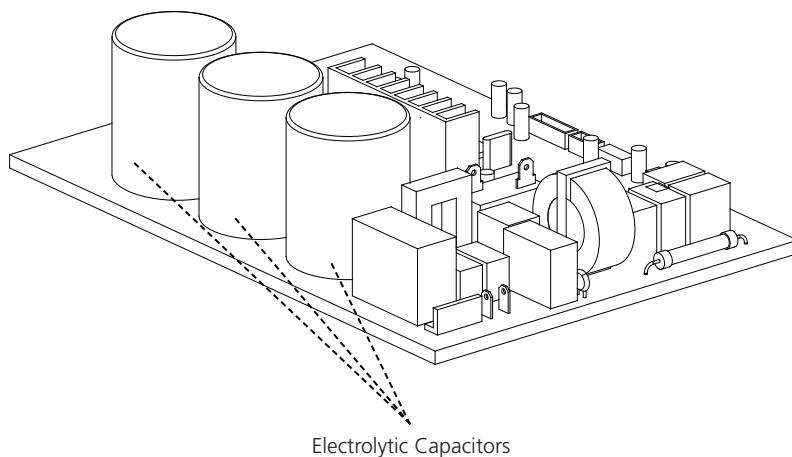

For other models, connect discharge resistance (approx. 100Ω 40W) or a soldering iron plug between the positive and negative terminals of the electrolytic capacitor. The terminals are located on the bottom surface of the outdoor PCB.

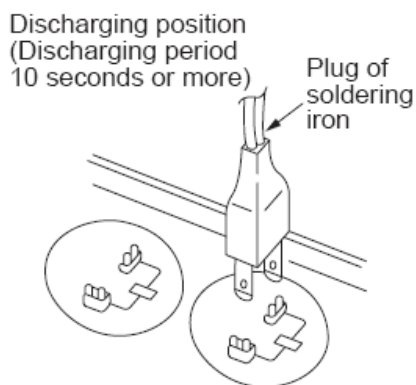

Note: This picture is for reference only. Actual appearances may vary.

2. General Troubleshooting

2.1 Error Display (Indoor Unit)

When the indoor unit encounters a recognized error, the indicator light will flash in a corresponding series, the timer display may turn on or begin flashing, and an error code will be displayed. These error codes are described in the following table:

Operation Lamp	Timer Lamp	Display	Error Information	Solution
1 times	OFF	E0	Indoor unit EEPROM parameter error	Page 73
2 times	OFF	E1	Indoor / outdoor units communication error	Page 74
3 times	OFF	E2	Zero-crossing signal detection error (for 7k model)	Page 76
4 times	OFF	E3	The indoor fan speed is operating outside of the normal range	Page 77
5 times	OFF	E4	Indoor room temperature sensor T1 is in open circuit or has short circuited	Page 80
6 times	OFF	E5	Evaporator coil temperature sensor T2 is in open circuit or has short circuited	Page 80
7 times	OFF	EC	Refrigerant leak detected	Page 81
1 times	ON	F0	Overload current protection	Page 82
2 times	ON	F1	Outdoor ambient temperature sensor T4 open circuit or short circuit	Page 80
3 times	ON	F2	Condenser coil temperature sensor T3 is in open circuit or has short circuited	Page 80
4 times	ON	F3	Compressor discharge temperature sensor TP open circuit or short circuit	Page 80
5 times	ON	F4	Outdoor unit EEPROM parameter error	Page 73
6 times	ON	F5	The outdoor fan speed is operating outside of the normal range	Page 77
1 times	FLASH	P0	IPM malfunction or IGBT over-strong current protection	Page 83
2 times	FLASH	P1	Over voltage or over low voltage protection	Page 84
3 times	FLASH	P2	High temperature protection of IPM module	Page 85
5 times	FLASH	P4	Inverter compressor drive error	Page 86

For other errors:

The display board may show a garbled code or a code undefined by the service manual. Ensure that this code is not a temperature reading.

Troubleshooting:

Test the unit using the remote control. If the unit does not respond to the remote, the indoor PCB requires replacement. If the unit responds, the display board requires replacement.

3. Error Diagnosis and Troubleshooting Without Error Code

WARNING

Be sure to turn off unit before any maintenance to prevent damage or injury.

3.1 Remote maintenance

SUGGESTION: When troubles occur, please check the following points with customers before field maintenance.

	Problem	Solution
1	Unit will not start	Page 66-67
2	The power switch is on but fans will not start	Page 66-67
3	The temperature on the display board cannot be set	Page 66-67
4	Unit is on but the wind is not cold(hot)	Page 66-67
5	Unit runs, but shortly stops	Page 66-67
6	The unit starts up and stops frequently	Page 66-67
7	Unit runs continuously but insufficient cooling(heating)	Page 66-67
8	Cool can not change to heat	Page 66-67
9	Unit is noisy	Page 66-67

3.2 Field maintenance

	Problem	Solution
1	Unit will not start	Page 68-69
2	Compressor will not start but fans run	Page 68-69
3	Compressor and condenser (outdoor) fan will not start	Page 68-69
4	Evaporator (indoor) fan will not start	Page 68-69
5	Condenser (Outdoor) fan will not start	Page 68-69
6	Unit runs, but shortly stops	Page 68-69
7	Compressor short-cycles due to overload	Page 68-69
8	High discharge pressure	Page 68-69
9	Low discharge pressure	Page 68-69
10	High suction pressure	Page 68-69
11	Low suction pressure	Page 68-69
12	Unit runs continuously but insufficient cooling	Page 68-69
13	Too cool	Page 68-69
14	Compressor is noisy	Page 68-69
15	Horizontal louver can not revolve	Page 68-69

1.Remote Maintenance	Electrical Circuit					Refrigerant Circuit								
Possible causes of trouble	Power failure	The main power tripped	Loose connections	Faulty transformer	The voltage is too high or too low	The remote control is powered off	Broken remote control	Dirty air filter	Dirty condenser fins	The setting temperature is higher/lower than the room's (cooling/heating)	The ambient temperature is too high/low when the mode is cooling/heating	Fan mode	SILENCE function is activated (optional function)	Frosting and defrosting frequently
Unit will not start	☆	☆	☆	☆										
The power switch is on but fans will not start			☆	☆	☆									
The temperature on the display board cannot be set						☆	☆							
Unit is on but the wind is not cold(hot)										☆	☆	☆		
Unit runs, but shortly stops					☆					☆	☆			
The unit starts up and stops frequently					☆						☆			☆
Unit runs continuously but insufficient cooling(heating)								☆	☆	☆	☆		☆	
Cool can not change to heat														
Unit is noisy														
Test method / remedy	Test voltage	Close the power switch	Inspect connections - tighten	Change the transformer	Test voltage	Replace the battery of the remote control	Replace the remote control	Clean or replace	Clean	Adjust the setting temperature	Turn the AC later	Adjust to cool mode	Turn off SILENCE function.	Turn the AC later

Others	
Check heat load	Heavy load condition
Tighten bolts or screws	Loosen hold down bolts and / or screws
Close all the windows and doors	Bad airproof
Remove the obstacles	The air inlet or outlet of either unit is blocked
Reconnect the power or press ON/OFF button on remote control to restart	Interference from cell phone towers and remote boosters
Remove them	Shipping plates remain attached

2.Field Maintenance	Electrical Circuit														
Possible causes of trouble	Power failure	Blown fuse or varistor	Loose connections	Shorted or broken wires	Safety device opens	Faulty thermostat / room temperature sensor	Wrong setting place of temperature sensor	Faulty transformer	Shorted or open capacitor	Faulty magnetic contactor for compressor	Faulty magnetic contactor for fan	Low voltage	Faulty stepping motor	Shorted or grounded compressor	Shorted or grounded fan motor
Unit will not start	☆	☆	☆	☆	☆			☆							
Compressor will not start but fans run				☆		☆			☆	☆				☆	
Compressor and condenser (outdoor) fan will not start				☆		☆				☆					
Evaporator (indoor) fan will not start				☆					☆		☆				☆
Condenser (Outdoor) fan will not start				☆		☆			☆	☆					☆
Unit runs, but shortly stops										☆		☆			
Compressor short-cycles due to overload										☆		☆			
High discharge pressure															
Low discharge pressure															
High suction pressure															
Low suction pressure															
Unit runs continuously but insufficient cooling															
Too cool						☆	☆								
Compressor is noisy															
Horizontal louver can not revolve			☆	☆									☆		
Test method / remedy	Test voltage	Inspect fuse type & size	Inspect connections - tighten	Test circuits with tester	Test continuity of safety device	Test continuity of thermostat / sensor & wiring	Place the temperature sensor at the central of the air inlet grille	Check control circuit with tester	Check capacitor with tester	Test continuity of coil & contacts	Test continuity of coil & contacts	Test voltage	Replace the stepping motor	Check resistance with multimeter	Check resistance with multimeter

Refrigerant Circuit												Others
Replace the compressor												Compressor stuck
Leak test												Shortage of refrigerant
Replace restricted part												Restricted liquid line
Clean or replace												Dirty air filter
Clean coil												Dirty evaporator coil
Check fan												Insufficient air through evaporator coil
Change charged refrigerant volume												Overcharge of refrigerant
Clean condenser or remove obstacle												Dirty or partially blocked condenser
Purge, evacuate and recharge												Air or incompressible gas in refrigerant cycle
Remove obstruction to air flow												Short cycling of condensing air
Remove obstruction in air or water flow												High temperature condensing medium
Remove obstruction in air or water flow												Insufficient condensing medium
Replace compressor												Broken compressor internal parts
Test compressor efficiency												Inefficient compressor
Replace valve												Expansion valve obstructed
Replace valve												Expansion valve or capillary tube closed completely
Replace valve												Leaking power element on expansion valve
Fix feeler bulb												Poor installation of feeler bulb
Check heat load												Heavy load condition
Tighten bolts or screws												Loosen hold down bolts and / or screws
Remove them												Shipping plates remain attached
Choose AC of larger capacity or add the number of AC												Poor choices of capacity
Rectify piping so as not to contact each other or with external plate												Contact of piping with other piping or external plate

4. Quick Maintenance by Error Code

If you do not have the time to test whether specific parts are faulty, you can directly change the required parts according to the error code.

You can find the parts to replace by error code in the following table.

Part requiring replacement	Error Code								
	E0	E1	E2	E3	E4	E5	E7	EC	F0
Indoor PCB	✓	✓	✓	✓	✓	✓	✓	✓	x
Outdoor PCB	x	✓	x	x	x	x	x	x	✓
Reactor	x	✓	x	x	x	x	x	x	x
Indoor fan motor	x	x	✓	✓	x	x	x	x	x
Outdoor fan motor	x	x	x	x	x	x	x	x	x
Temperature sensor	x	x	x	x	✓	✓	x	✓	x
T2 Sensor	x	x	x	x	x	x	x	✓	x
Additional refrigerant	x	x	x	x	x	x	x	x	x
Compressor	x	x	x	x	x	x	x	x	✓
IPM board	x	x	x	x	x	x	x	x	x
Outdoor unit	x	x	x	x	x	x	x	x	✓
Display board	x	x	x	x	x	x	✓	x	x

Part requiring replacement	Error Code								
	F1	F2	F3	F4	F5	P0	P1	P2	P4
Indoor PCB	x	x	x	x	x	x	x	x	x
Outdoor PCB	✓	✓	✓	✓	✓	✓	✓	✓	✓
Reactor	x	x	x	x	x	x	✓	x	x
Indoor fan motor	x	x	x	x	x	x	x	x	x
Outdoor fan motor	x	x	x	x	✓	x	x	x	x
Temperature sensor	✓	✓	✓	x	x	x	x	x	x
T2 Sensor	x	x	x	x	x	x	x	x	x
Additional refrigerant	x	x	x	x	x	x	x	x	x
Compressor	x	x	x	x	x	✓	x	x	✓
IPM board	x	x	x	x	x	✓	✓	x	✓
Outdoor unit	x	x	x	x	x	x	x	x	x

5. Troubleshooting by Error Code

5.1 Common Check Procedures

5.1.1 Temperature Sensor Check

Disconnect the temperature sensor from PCB, measure the resistance value with a tester.

Temperature Sensors.

Room temp.(T1) sensor,

Indoor coil temp.(T2) sensor,

Outdoor coil temp.(T3) sensor,

Outdoor ambient temp.(T4) sensor,

Compressor discharge temp.(Tp) sensor.

Measure the resistance value of each winding by using the multi-meter.

5.1.2 Compressor checking

Measure the resistance value of each winding by using the tester.

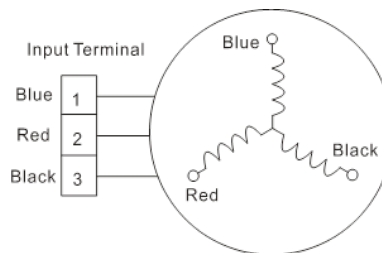

Position	Resistance Value				
	ASK89D53UEZ	ASN98D22UFZ	ASM135D23UFZ	ASN140D21UFZ	ATF235D22UMT
Blue - Red	2.35Ω (20°C/68°F)	1.57Ω (20°C/68°F)	1.75Ω (20°C/68°F)	1.28Ω (20°C/68°F)	0.75Ω (20°C/68°F)
Blue - Black					
Red - Blue					



5.1.3 IPM Continuity Check

Turn off the power, let the large capacity electrolytic capacitors discharge completely, and dismount the IPM. Use a digital tester to measure the resistance between P and UVWN; UVW and N.

Digital tester		Normal resistance value	Digital tester		Normal resistance value
(+)Red	(-)Black		(+)Red	(-)Black	
P	N	∞ (Several MΩ)	U	N	∞ (Several MΩ)
	U		V		
	V		W		
	W		(+)Red		

5.2 E0/F4 (EEPROM parameter error)

Description: Indoor or outdoor PCB main chip does not receive feedback from EEPROM chip.

Recommended parts to prepare:

- Indoor PCB
- Outdoor PCB

Troubleshooting and repair:

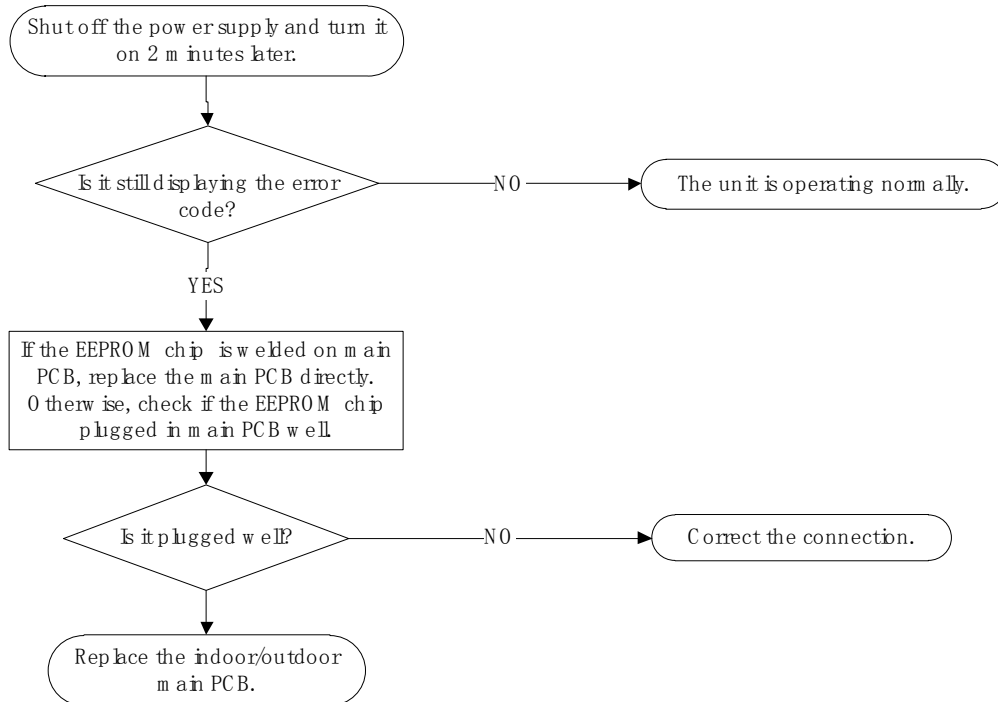

Remarks:

The location of the EEPROM chip on the indoor and outdoor PCB is shown in the following two images:

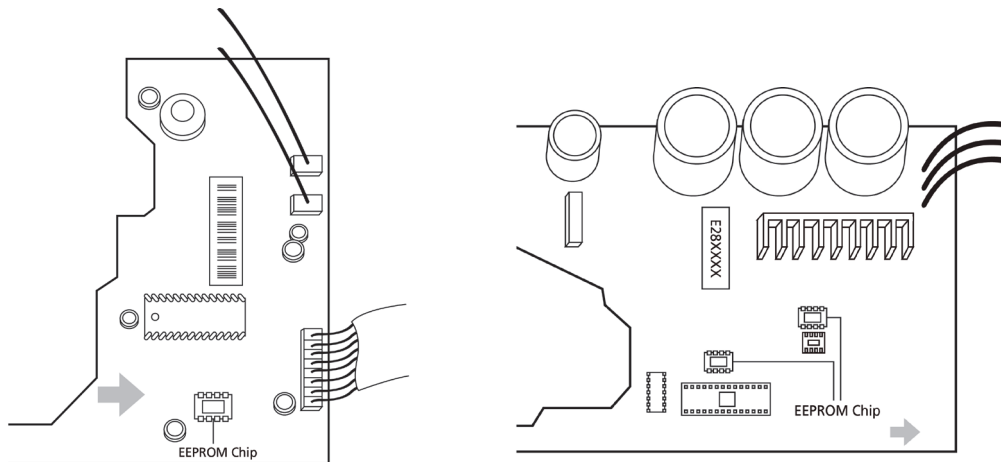

Note: These images are for reference only.

5.3 E1 (Indoor and outdoor unit communication error)

Description: The indoor unit has not received feedback from the outdoor unit for 110 seconds, four consecutive times.

Recommended parts to prepare:

- Indoor PCB
- Outdoor PCB
- Reactor

Troubleshooting and repair:

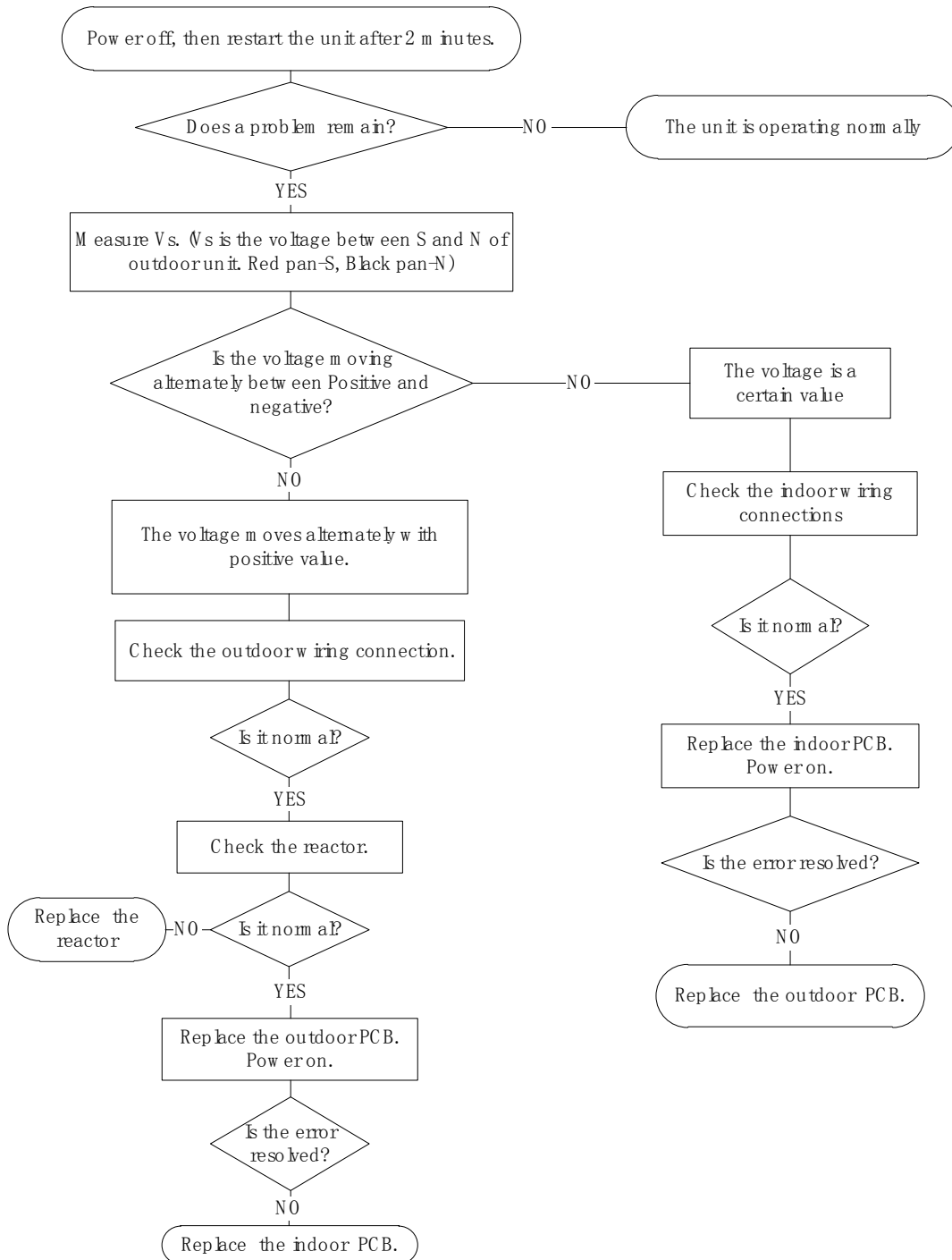

Remarks:

- Use a multimeter to test the DC voltage between 2 port and 3 port of outdoor unit. The red pin of multimeter connects with 2 port while the black pin is for 3 port.
- When AC is normal running, the voltage will move alternately between -25V to 25V.
- If the outdoor unit has malfunction, the voltage will move alternately with positive value.
- While if the indoor unit has malfunction, the voltage will be a certain value.

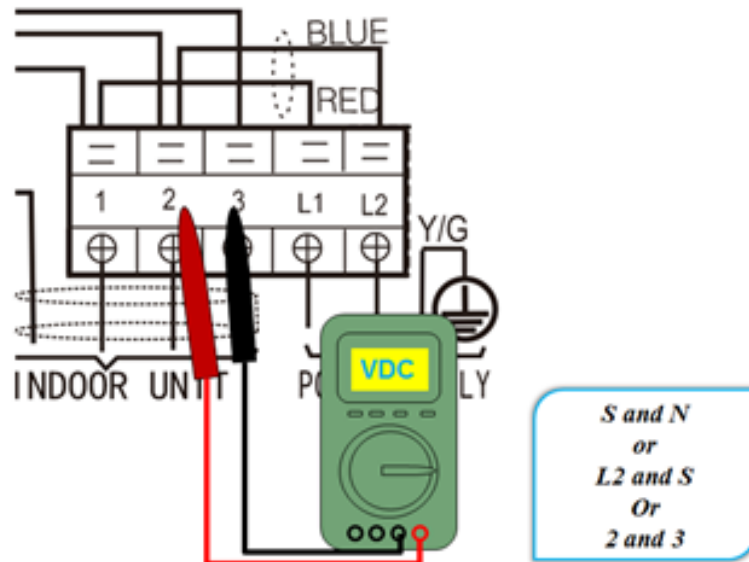

- Use a multimeter to test the resistance of the reactor which does not connect with capacitor.
- The normal value should be around zero ohm. Otherwise, the reactor must have malfunction.



5.4 E2 (Zero crossing detection error diagnosis and solution)

Description: When PCB does not receive zero crossing signal feedback for 4 minutes or the zero crossing signal time interval is abnormal.

Recommended parts to prepare:

- Connection mistake
- PCB faulty

Troubleshooting and repair:

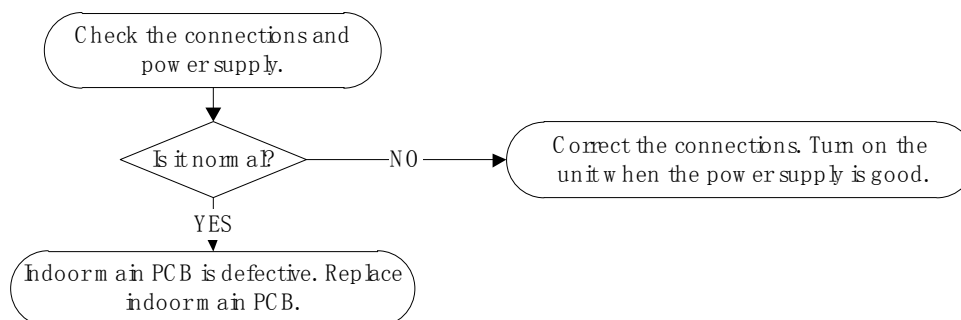

5.5 E3/F5(Fan speed is operating outside of the normal range)

Description: When the indoor fan speed keeps too low (300RPM) for certain time, the unit will stop and the LED will display the failure(E3).

When the outdoor fan speed registers below aRPM (for MOB31-18HFN1-QRD0GW, MOCA30-24HFN1-QRD0GW, MOCA30-24HFN1-QRC8GW, a is 200; for other models, a is 300.) or over 1500RPM for an extended period of time, the unit will stop and the LED will display the failure(F5).

Recommended parts to prepare:

- Wiring mistake
- Faulty fan assembly
- Faulty fan motor
- Faulty PCB

Troubleshooting and repair:

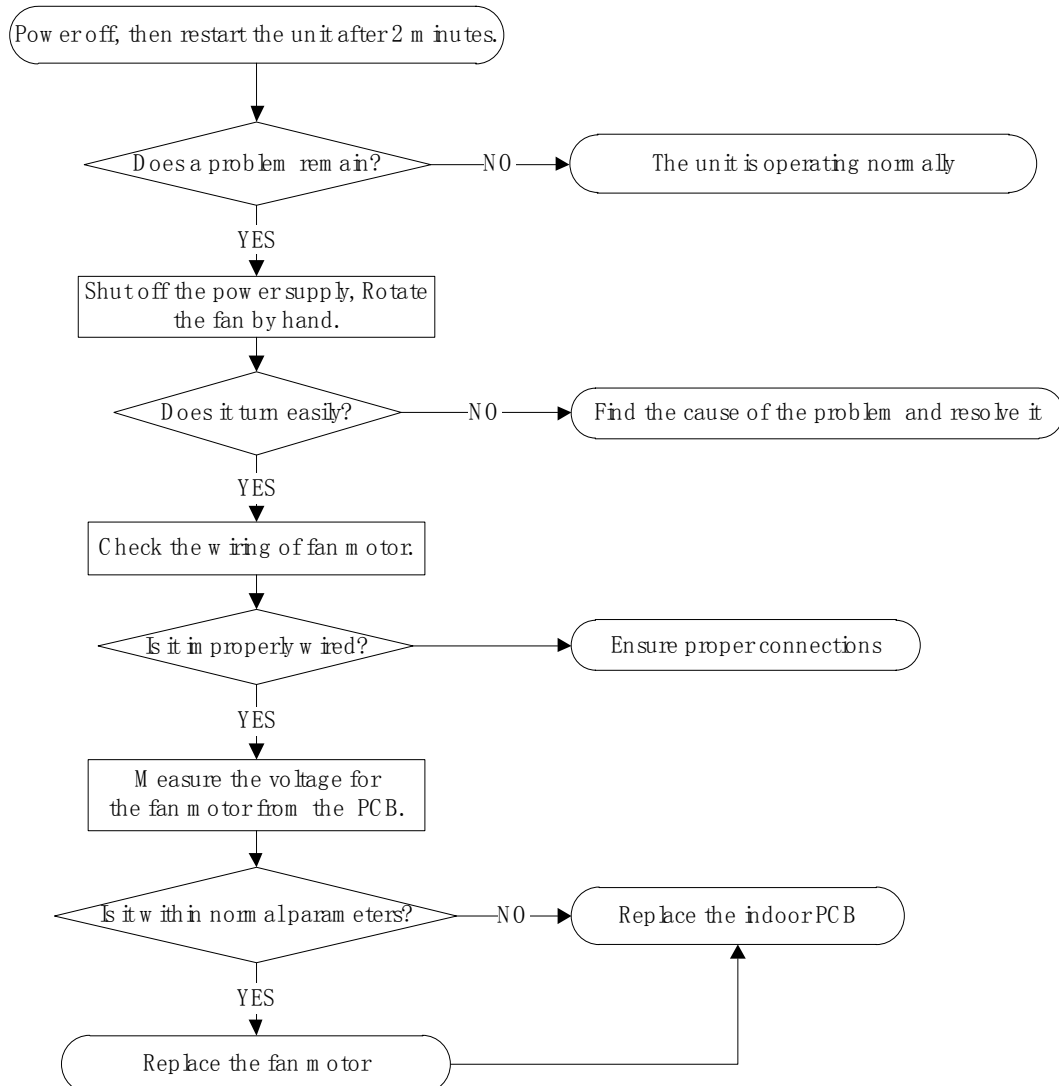

Index:

1. Indoor or Outdoor DC Fan Motor(control chip is in fan motor)

Power on and when the unit is in standby, measure the voltage of pin1-pin3, pin4-pin3 in fan motor connector. If the value of the voltage is not in the range showing in below table, the PCB must has problems and need to be replaced.

- DC motor voltage input and output (voltage: 220-240V~):

No.	Color	Signal	Voltage
1	Red	Vs/Vm	280V~380V
2	---	---	---
3	Black	GND	0V
4	White	Vcc	14-17.5V
5	Yellow	Vsp	0~5.6V
6	Blue	FG	14-17.5V

- DC motor voltage input and output (voltage: 115V~):

No.	Color	Signal	Voltage
1	Red	Vs/Vm	140V~190V
2	---	---	---
3	Black	GND	0V
4	White	Vcc	14-17.5V
5	Yellow	Vsp	0~5.6V
6	Blue	FG	14-17.5V

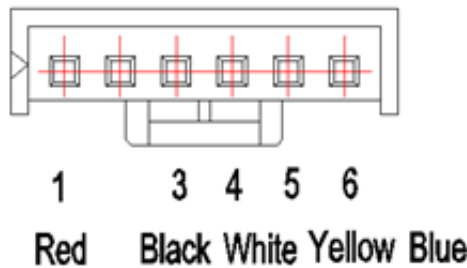

2. Outdoor DC Fan Motor (control chip is in outdoor PCB)

Release the UVW connector. Measure the resistance of U-V, U-W, V-W. If the resistance is not equal to each other, the fan motor must has problems and need to be replaced. otherwise the PCB must has problems and need to be replaced.

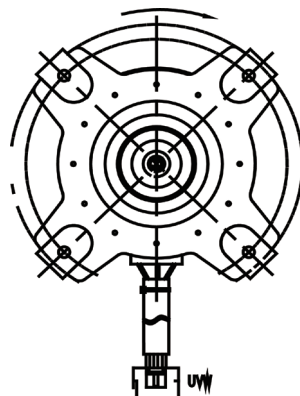

3. Indoor AC Fan Motor

Power on and set the unit running in fan mode at high fan speed. After running for 15 seconds, measure the voltage of pin1 and pin2. If the value of the voltage is less than 100V(208~240V power supply) or 50V(115V power supply), the PCB must has problems and need to be replaced.

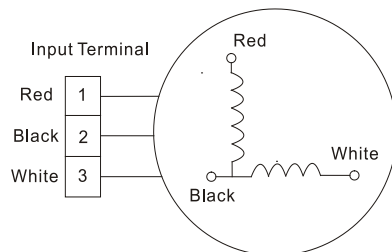

5.6 E4/E5/F1/F2/F3 (Open circuit or short circuit of temperature sensor diagnosis and solution)

Description: If the sampling voltage is lower than 0.06V or higher than 4.94V, the LED will display the failure.

Recommended parts to prepare:

- Wiring mistake
- Faulty sensor
- Faulty PCB

Troubleshooting and repair:

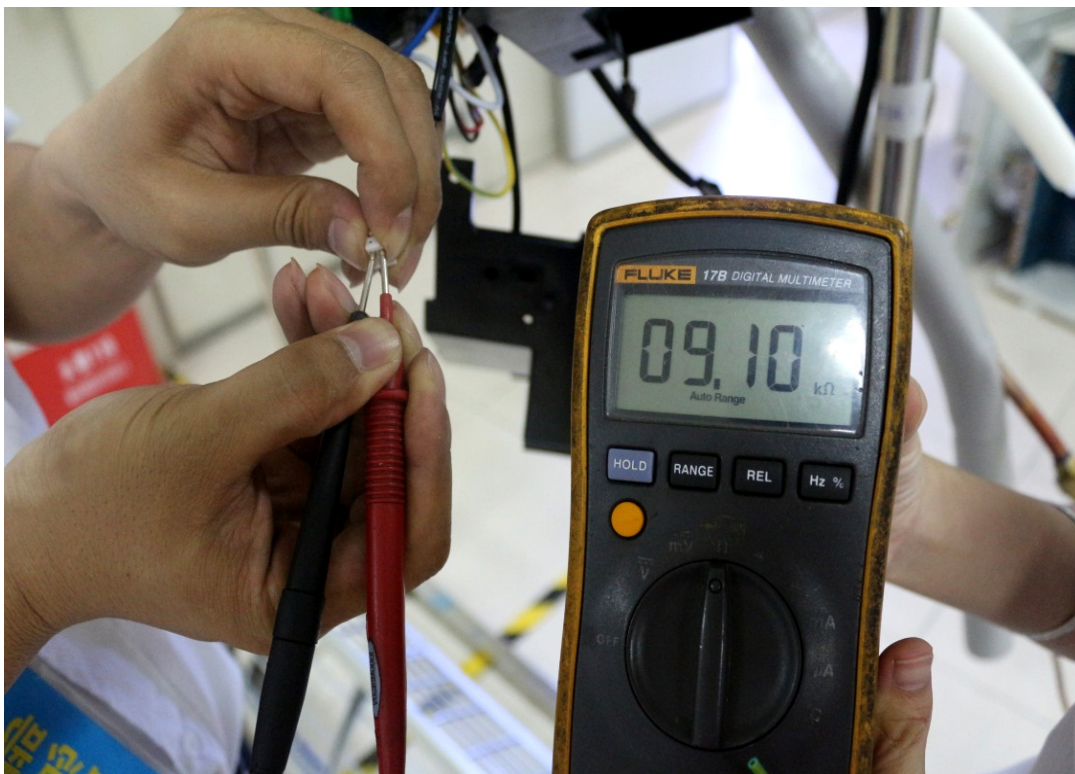
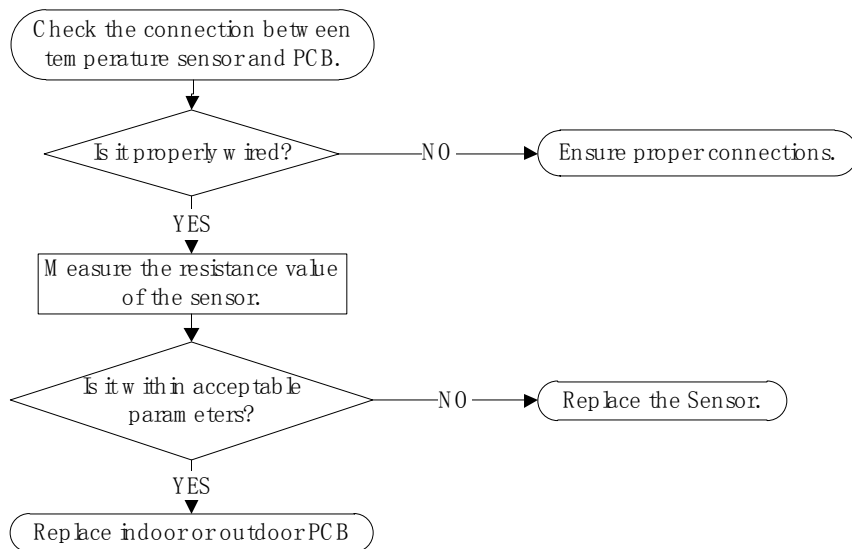

5.7 EC (Refrigerant Leakage Detection diagnosis and solution)

Description: Define the evaporator coil temp.T2 of the compressor just starts running as Tcool.

In the beginning 8 minutes after the compressor starts up, if $T2 < T_{cool} - 1^{\circ}\text{C}$ ($T_{cool} - 33.8^{\circ}\text{F}$) does not keep continuous 4 seconds and compressor running frequency higher than 50Hz does not keep continuous 3 minutes, and this situation happens 3 times, the display area will show "EC" and AC will turn off.

Recommended parts to prepare:

- Faulty T2 sensor
- Faulty indoor PCB
- System problems, such as leakage or blockages

Troubleshooting and repair:

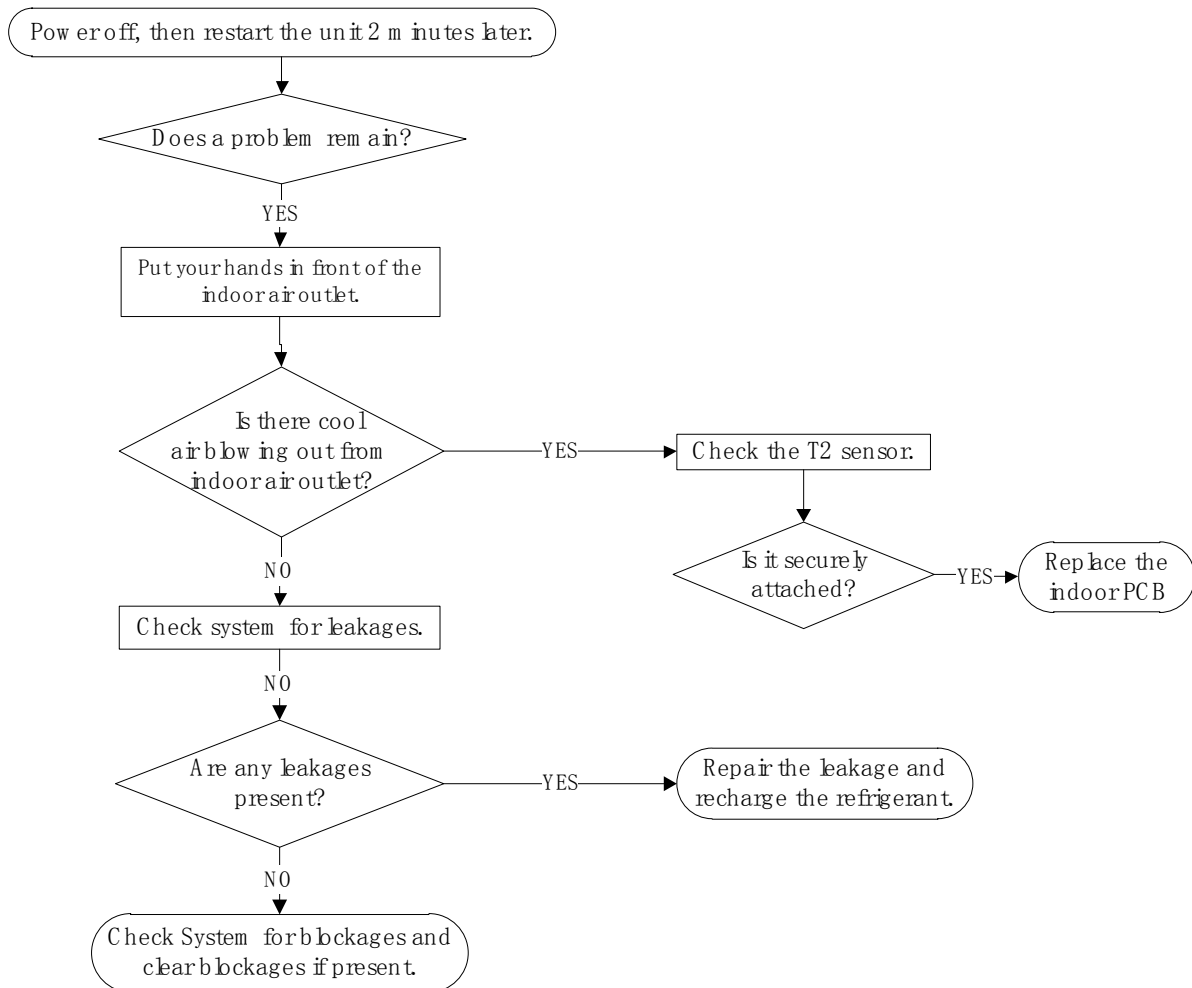

5.8 F0(Overload current protection diagnosis and solution)

Description: An abnormal current rise is detected by checking the specified current detection circuit.

Recommended parts to prepare:

- Power supply problems.
- System blockage
- Faulty PCB
- Wiring mistake
- Compressor malfunction

Troubleshooting and repair:

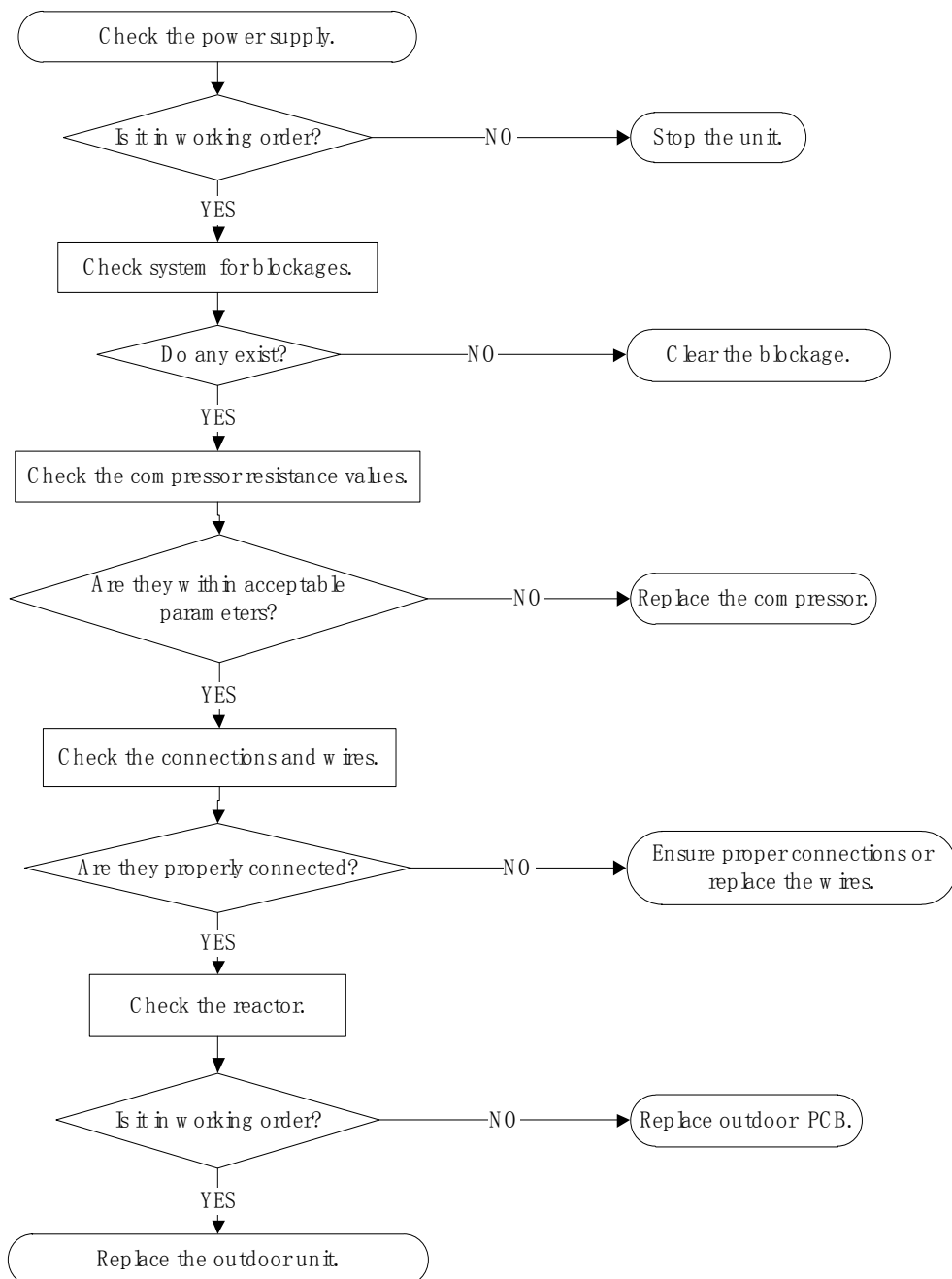

5.9 P0(IPM malfunction or IGBT over-strong current protection diagnosis and solution)

Description: When the voltage signal the IPM sends to the compressor drive chip is abnormal, the display LED shows “P0” and the AC turn off.

Recommended parts to prepare:

- Wiring mistake
- IPM malfunction
- Faulty outdoor fan assembly
- Compressor malfunction
- Faulty outdoor PCB

Troubleshooting and repair:

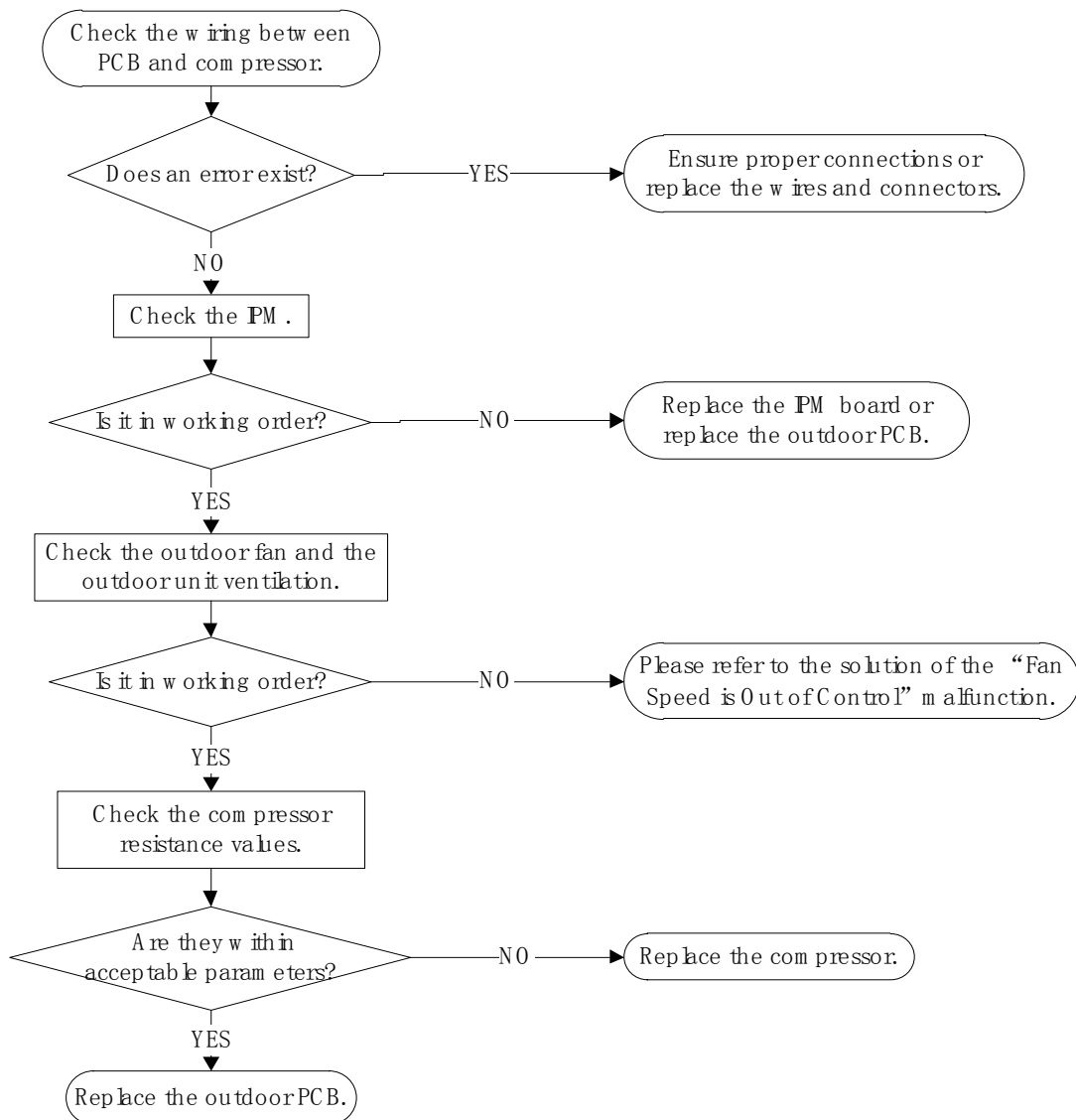

5.10 P1(Over voltage or too low voltage protection diagnosis and solution)

Description: Abnormal increases or decreases in voltage are detected by checking the specified voltage detection circuit.

Recommended parts to prepare:

- Power supply issues
- System leakage or blockage
- Faulty PCB

Troubleshooting and repair:

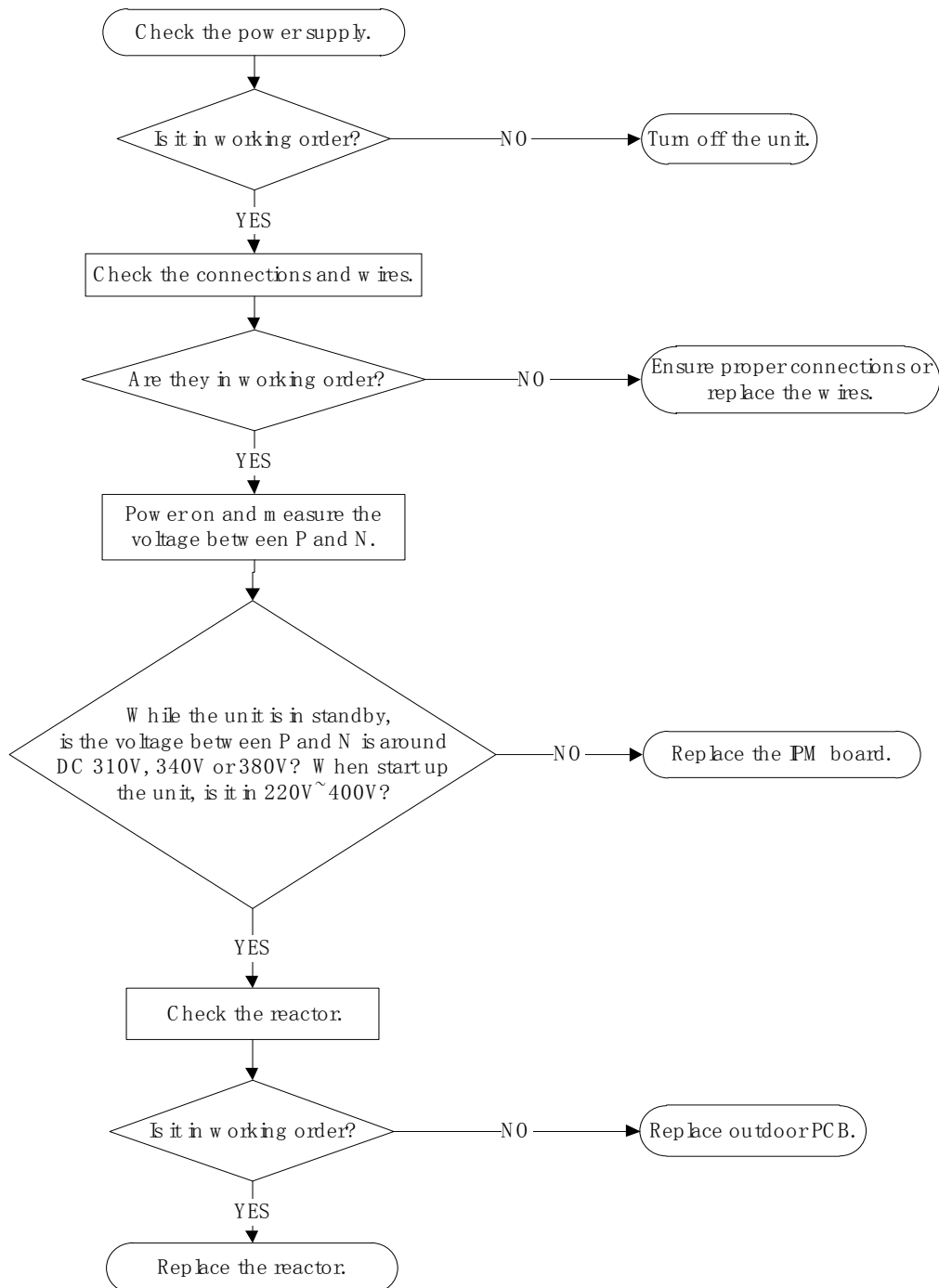

5.11 P2(High temperature protection of IPM module diagnosis and solution)

Description: If the temperature of IPM module is higher than setting value, the LED displays this failure code.

Recommended parts to prepare:

- Faulty PCB
- Connection problems

Troubleshooting and repair:

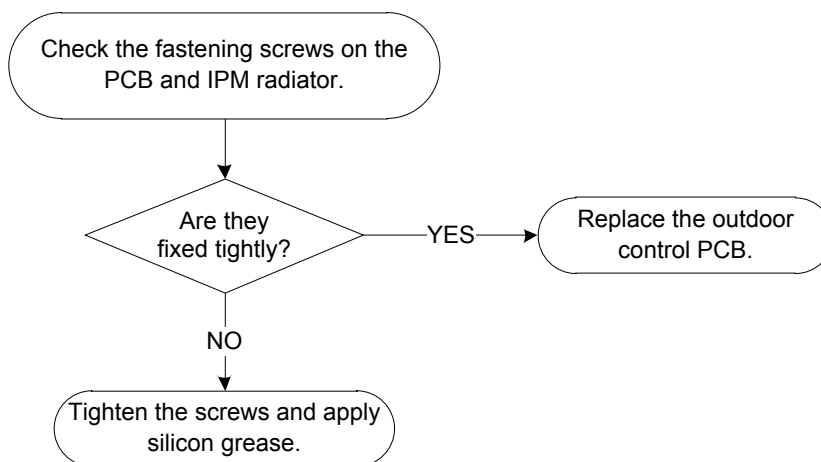

5.12 P4(Inverter compressor drive error diagnosis and solution)

Description: An abnormal inverter compressor drive is detected by a special detection circuit, including communication signal detection, voltage detection, compressor rotation speed signal detection and so on.

Recommended parts to prepare:

- Wiring mistake
- PM malfunction
- Faulty outdoor fan assembly
- Compressor malfunction
- Faulty outdoor PCB

Troubleshooting and repair:

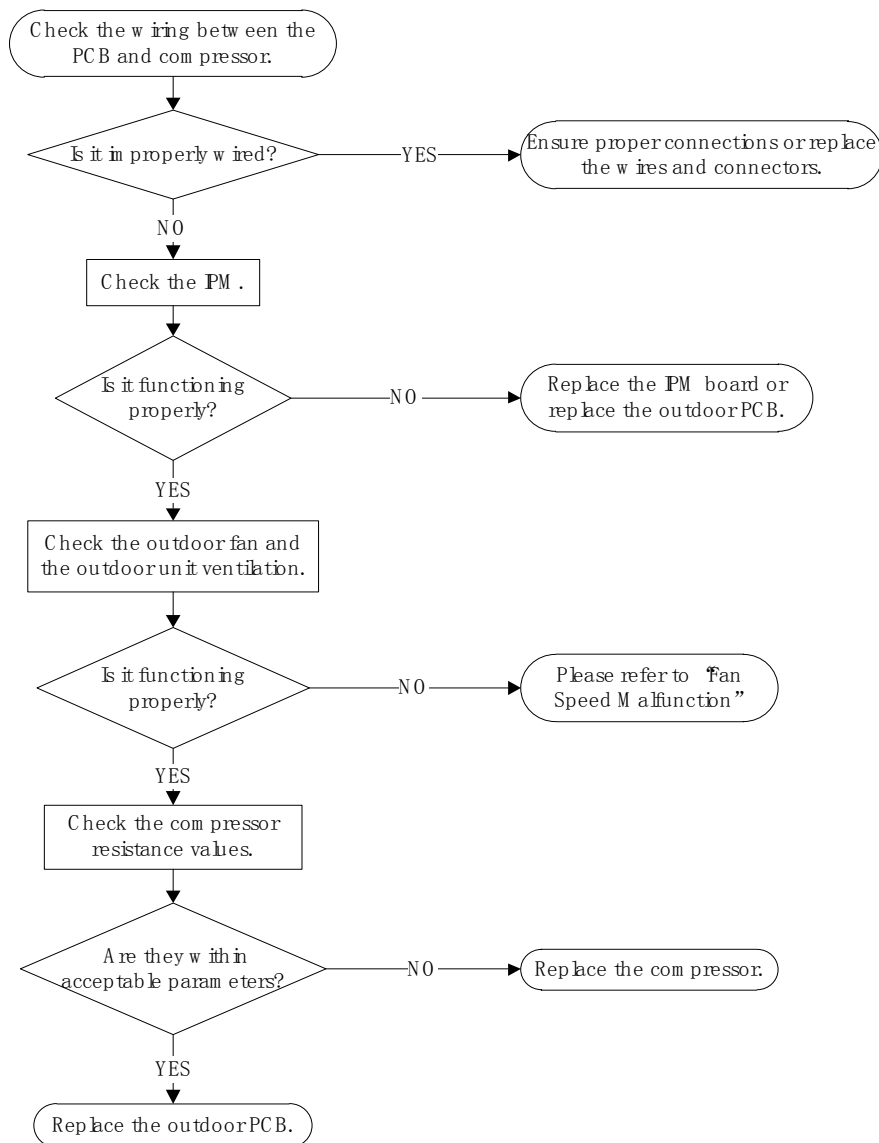

Appendix

Contents

i)	Temperature Sensor Resistance Value Table for T1, T2, T3, and T4 (°C – K)	88
ii)	Temperature Sensor Resistance Value Table for TP (°C --K).....	89
iii)	Pressure On Service Port	90

i) Temperature Sensor Resistance Value Table for T1,T2,T3 and T4 (°C – K)

°C	°F	K Ohm	°C	°F	K Ohm	°C	°F	K Ohm	°C	°F	K Ohm
-20	-4	115.266	20	68	12.6431	60	140	2.35774	100	212	0.62973
-19	-2	108.146	21	70	12.0561	61	142	2.27249	101	214	0.61148
-18	0	101.517	22	72	11.5	62	144	2.19073	102	216	0.59386
-17	1	96.3423	23	73	10.9731	63	145	2.11241	103	217	0.57683
-16	3	89.5865	24	75	10.4736	64	147	2.03732	104	219	0.56038
-15	5	84.219	25	77	10	65	149	1.96532	105	221	0.54448
-14	7	79.311	26	79	9.55074	66	151	1.89627	106	223	0.52912
-13	9	74.536	27	81	9.12445	67	153	1.83003	107	225	0.51426
-12	10	70.1698	28	82	8.71983	68	154	1.76647	108	226	0.49989
-11	12	66.0898	29	84	8.33566	69	156	1.70547	109	228	0.486
-10	14	62.2756	30	86	7.97078	70	158	1.64691	110	230	0.47256
-9	16	58.7079	31	88	7.62411	71	160	1.59068	111	232	0.45957
-8	18	56.3694	32	90	7.29464	72	162	1.53668	112	234	0.44699
-7	19	52.2438	33	91	6.98142	73	163	1.48481	113	235	0.43482
-6	21	49.3161	34	93	6.68355	74	165	1.43498	114	237	0.42304
-5	23	46.5725	35	95	6.40021	75	167	1.38703	115	239	0.41164
-4	25	44	36	97	6.13059	76	169	1.34105	116	241	0.4006
-3	27	41.5878	37	99	5.87359	77	171	1.29078	117	243	0.38991
-2	28	39.8239	38	100	5.62961	78	172	1.25423	118	244	0.37956
-1	30	37.1988	39	102	5.39689	79	174	1.2133	119	246	0.36954
0	32	35.2024	40	104	5.17519	80	176	1.17393	120	248	0.35982
1	34	33.3269	41	106	4.96392	81	178	1.13604	121	250	0.35042
2	36	31.5635	42	108	4.76253	82	180	1.09958	122	252	0.3413
3	37	29.9058	43	109	4.5705	83	181	1.06448	123	253	0.33246
4	39	28.3459	44	111	4.38736	84	183	1.03069	124	255	0.3239
5	41	26.8778	45	113	4.21263	85	185	0.99815	125	257	0.31559
6	43	25.4954	46	115	4.04589	86	187	0.96681	126	259	0.30754
7	45	24.1932	47	117	3.88673	87	189	0.93662	127	261	0.29974
8	46	22.5662	48	118	3.73476	88	190	0.90753	128	262	0.29216
9	48	21.8094	49	120	3.58962	89	192	0.8795	129	264	0.28482
10	50	20.7184	50	122	3.45097	90	194	0.85248	130	266	0.2777
11	52	19.6891	51	124	3.31847	91	196	0.82643	131	268	0.27078
12	54	18.7177	52	126	3.19183	92	198	0.80132	132	270	0.26408
13	55	17.8005	53	127	3.07075	93	199	0.77709	133	271	0.25757
14	57	16.9341	54	129	2.95896	94	201	0.75373	134	273	0.25125
15	59	16.1156	55	131	2.84421	95	203	0.73119	135	275	0.24512
16	61	15.3418	56	133	2.73823	96	205	0.70944	136	277	0.23916
17	63	14.6181	57	135	2.63682	97	207	0.68844	137	279	0.23338
18	64	13.918	58	136	2.53973	98	208	0.66818	138	280	0.22776
19	66	13.2631	59	138	2.44677	99	210	0.64862	139	282	0.22231

ii) Temperature Sensor Resistance Value Table for TP (°C --K)

°C	°F	K Ohm	°C	°F	K Ohm	°C	°F	K Ohm	°C	°F	K Ohm
-20	-4	542.7	20	68	68.66	60	140	13.59	100	212	3.702
-19	-2	511.9	21	70	65.62	61	142	13.11	101	214	3.595
-18	0	483	22	72	62.73	62	144	12.65	102	216	3.492
-17	1	455.9	23	73	59.98	63	145	12.21	103	217	3.392
-16	3	430.5	24	75	57.37	64	147	11.79	104	219	3.296
-15	5	406.7	25	77	54.89	65	149	11.38	105	221	3.203
-14	7	384.3	26	79	52.53	66	151	10.99	106	223	3.113
-13	9	363.3	27	81	50.28	67	153	10.61	107	225	3.025
-12	10	343.6	28	82	48.14	68	154	10.25	108	226	2.941
-11	12	325.1	29	84	46.11	69	156	9.902	109	228	2.86
-10	14	307.7	30	86	44.17	70	158	9.569	110	230	2.781
-9	16	291.3	31	88	42.33	71	160	9.248	111	232	2.704
-8	18	275.9	32	90	40.57	72	162	8.94	112	234	2.63
-7	19	261.4	33	91	38.89	73	163	8.643	113	235	2.559
-6	21	247.8	34	93	37.3	74	165	8.358	114	237	2.489
-5	23	234.9	35	95	35.78	75	167	8.084	115	239	2.422
-4	25	222.8	36	97	34.32	76	169	7.82	116	241	2.357
-3	27	211.4	37	99	32.94	77	171	7.566	117	243	2.294
-2	28	200.7	38	100	31.62	78	172	7.321	118	244	2.233
-1	30	190.5	39	102	30.36	79	174	7.086	119	246	2.174
0	32	180.9	40	104	29.15	80	176	6.859	120	248	2.117
1	34	171.9	41	106	28	81	178	6.641	121	250	2.061
2	36	163.3	42	108	26.9	82	180	6.43	122	252	2.007
3	37	155.2	43	109	25.86	83	181	6.228	123	253	1.955
4	39	147.6	44	111	24.85	84	183	6.033	124	255	1.905
5	41	140.4	45	113	23.89	85	185	5.844	125	257	1.856
6	43	133.5	46	115	22.89	86	187	5.663	126	259	1.808
7	45	127.1	47	117	22.1	87	189	5.488	127	261	1.762
8	46	121	48	118	21.26	88	190	5.32	128	262	1.717
9	48	115.2	49	120	20.46	89	192	5.157	129	264	1.674
10	50	109.8	50	122	19.69	90	194	5	130	266	1.632
11	52	104.6	51	124	18.96	91	196	4.849			
12	54	99.69	52	126	18.26	92	198	4.703			
13	55	95.05	53	127	17.58	93	199	4.562			
14	57	90.66	54	129	16.94	94	201	4.426			
15	59	86.49	55	131	16.32	95	203	4.294			
16	61	82.54	56	133	15.73	96	205	4.167			
17	63	78.79	57	135	15.16	97	207	4.045			
18	64	75.24	58	136	14.62	98	208	3.927			
19	66	71.86	59	138	14.09	99	210	3.812			

iii) Pressure On Service Port(R410A)

Cooling chart:

°F(°C)	ODT		0(-17)	5(-15)	15 (9.44)	45 (7.22)	75 (23.89)	85 (29.44)	95 (35)	105 (40.56)	115 (46.11)	120 (48.89)
	IDT											
BAR	70/59		6.4	6.5	7.3	8.0	8.2	7.8	8.1	8.6	10.1	10.6
BAR	75/63		6.7	6.8	7.9	8.6	8.6	8.3	8.7	9.1	10.7	11.2
BAR	80/67		7.1	7.2	8.5	9.5	9.3	8.9	9.1	9.6	11.2	11.9
BAR	90/73		7.7	7.8	9.6	10.5	10.3	9.5	10.0	10.6	12.4	13.0

°F(°C)	ODT		0(-17)	5(-15)	15 (9.44)	45 (7.22)	75 (23.89)	85 (29.44)	95 (35)	105 (40.56)	115 (46.11)	120 (48.89)
	IDT											
PSI	70/59		93	94	106	116	119	113	117	125	147	154
PSI	75/63		97	99	115	125	124	120	126	132	155	162
PSI	80/67		103	104	123	138	135	129	132	140	162	173
PSI	90/73		112	113	139	152	149	138	145	154	180	189

°F(°C)	ODT		0(-17)	5(-15)	15 (9.44)	45 (7.22)	75 (23.89)	85 (29.44)	95 (35)	105 (40.56)	115 (46.11)	120 (48.89)
	IDT											
MPA	70/59		0.64	0.65	0.73	0.8	0.82	0.78	0.81	0.86	1.01	1.06
MPA	75/63		0.67	0.68	0.79	0.86	0.86	0.83	0.87	0.91	1.07	1.12
MPA	80/67		0.71	0.72	0.85	0.95	0.93	0.89	0.91	0.96	1.12	1.19
MPA	90/73		0.77	0.78	0.96	1.05	1.03	0.95	1	1.06	1.24	1.3

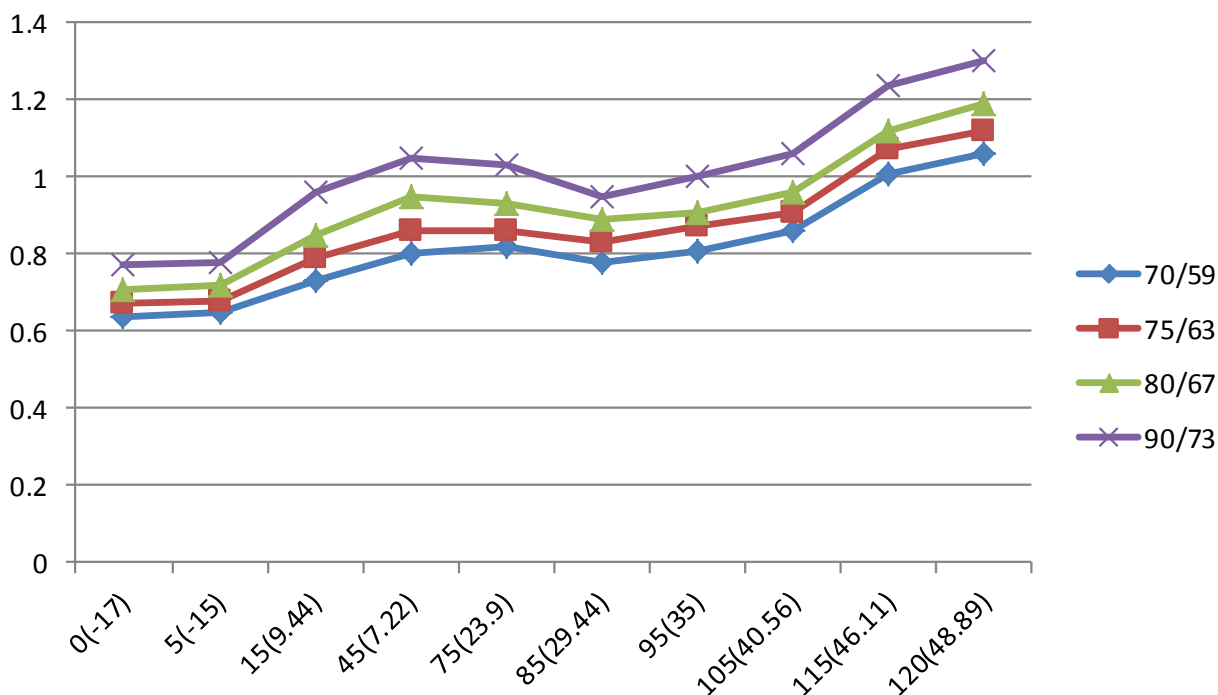

Heating chart:

°F(°C)	ODT		57/53 (13.89/11.67)	47/43 (8.33/6.11)	37/33 (2.78/0.56)	27/23 (-2.78/-5)	17/13 (-8.33/- 10.56)	0/-2 (-17/-19)	-17/-18 (-27/-28)
	IDT								
BAR	55		30.3	28.5	25.3	22.8	20.8	18.5	16.5
BAR	65		32.5	30.0	26.6	25.4	23.3	20.5	19.0
BAR	75		33.8	31.5	27.8	26.3	24.9	21.5	20.0

°F(°C)	ODT		57/53 (13.89/11.67)	47/43 (8.33/6.11)	37/33 (2.78/0.56)	27/23 (-2.78/-5)	17/13 (-8.33/- 10.56)	0/-2 (-17/-19)	-17/-18 (-27/-28)
	IDT								
PSI	55		439	413	367	330	302	268	239
PSI	65		471	435	386	368	339	297	276
PSI	75		489	457	403	381	362	312	290

°F(°C)	ODT		57/53 (13.89/11.67)	47/43 (8.33/6.11)	37/33 (2.78/0.56)	27/23 (-2.78/-5)	17/13 (-8.33/- 10.56)	0/-2 (-17/-19)	-17/-18 (-27/-28)
	IDT								
MPA	55		3.03	2.85	2.53	2.28	2.08	1.85	1.65
MPA	65		3.25	3.00	2.66	2.54	2.33	2.05	1.90
MPA	75		3.38	3.15	2.78	2.63	2.49	2.15	2.00

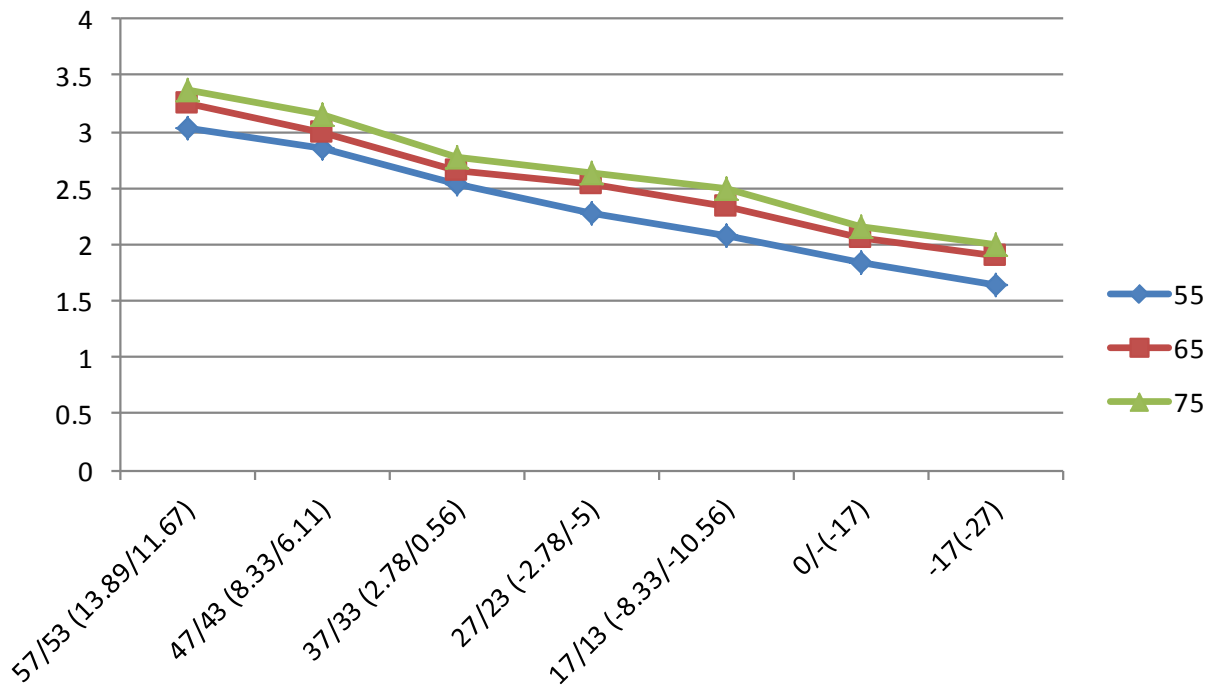

Pressure On Service Port(R32)

Cooling chart:

°F(°C)	ODT		0(-17)	5(-15)	15 (9.44)	45 (7.22)	75 (23.89)	85 (29.44)	95 (35)	105 (40.56)	115 (46.11)	120 (48.89)
	IDT											
BAR	70/59		6.5	6.6	7.4	8.2	8.4	8.0	8.3	8.8	10.3	10.8
BAR	75/63		6.8	6.9	8.1	8.8	8.8	8.5	8.9	9.3	10.9	11.4
BAR	80/67		7.2	7.3	8.7	9.7	9.5	9.1	9.3	9.8	11.4	12.1
BAR	90/73		7.9	8.0	9.8	10.7	10.5	9.7	10.2	10.8	12.6	13.3

°F(°C)	ODT		0(-17)	5(-15)	15 (9.44)	45 (7.22)	75 (23.89)	85 (29.44)	95 (35)	105 (40.56)	115 (46.11)	120 (48.89)
	IDT											
PSI	70/59		95	96	108	118	121	115	119	128	150	157
PSI	75/63		99	101	117	128	126	122	129	135	158	165
PSI	80/67		105	106	125	141	138	132	135	143	165	176
PSI	90/73		114	115	142	155	152	141	148	157	184	193

°F(°C)	ODT		0(-17)	5(-15)	15 (9.44)	45 (7.22)	75 (23.89)	85 (29.44)	95 (35)	105 (40.56)	115 (46.11)	120 (48.89)
	IDT											
MPA	70/59		0.65	0.66	0.74	0.82	0.84	0.80	0.83	0.88	1.03	1.08
MPA	75/63		0.68	0.69	0.81	0.88	0.88	0.85	0.89	0.93	1.09	1.14
MPA	80/67		0.72	0.73	0.87	0.97	0.95	0.91	0.93	0.98	1.14	1.21
MPA	90/73		0.79	0.80	0.98	1.07	1.05	0.97	1.02	1.08	1.26	1.33

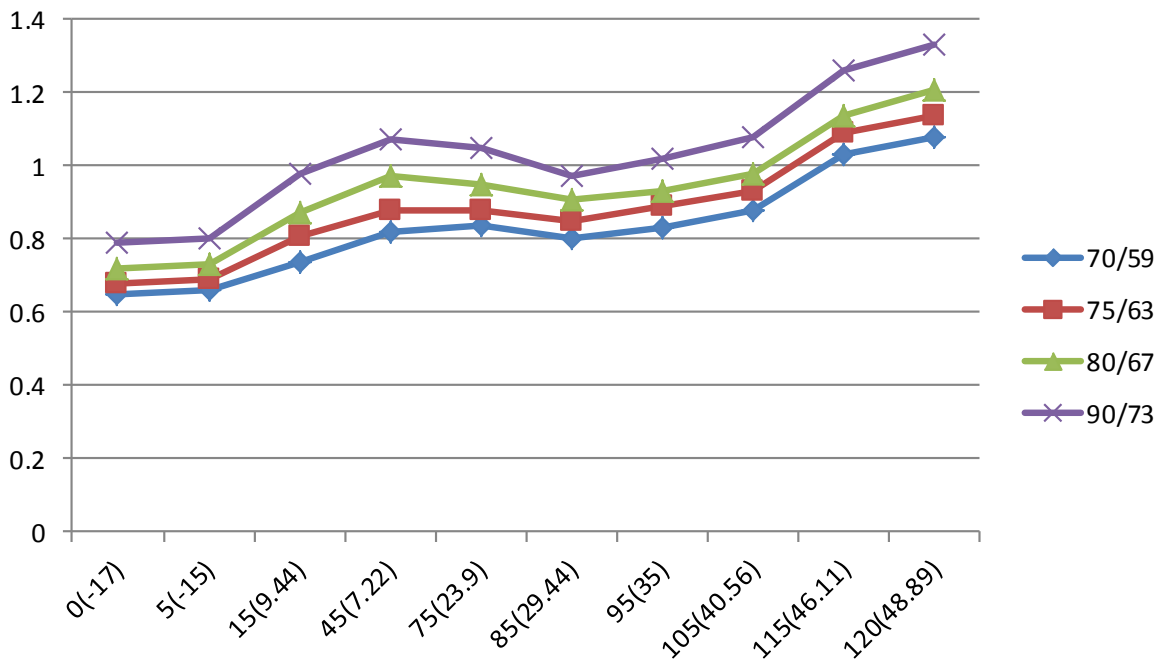

Heating chart:

°F(°C)	ODT		57/53 (13.89/11.67)	47/43 (8.33/6.11)	37/33 (2.78/0.56)	27/23 (-2.78/-5)	17/13 (-8.33/-10.56)	0/-2 (-17/-19)	-17/-18 (-27/-28)
	IDT								
BAR	55		30.9	29.1	25.8	23.3	21.2	18.9	16.8
BAR	65		33.2	30.6	27.1	25.9	23.8	20.9	19.4
BAR	75		34.5	32.1	28.4	26.8	25.4	21.9	20.4

°F(°C)	ODT		57/53 (13.89/11.67)	47/43 (8.33/6.11)	37/33 (2.78/0.56)	27/23 (-2.78/-5)	17/13 (-8.33/-10.56)	0/-2 (-17/-19)	-17/-18 (-27/-28)
	IDT								
PSI	55		448	421	374	337	308	273	244
PSI	65		480	444	394	375	346	303	282
PSI	75		499	466	411	389	369	318	296

°F(°C)	ODT		57/53 (13.89/11.67)	47/43 (8.33/6.11)	37/33 (2.78/0.56)	27/23 (-2.78/-5)	17/13 (-8.33/-10.56)	0/-2 (-17/-19)	-17/-18 (-27/-28)
	IDT								
MPA	55		3.09	2.91	2.58	2.33	2.12	1.89	1.68
MPA	65		3.32	3.06	2.71	2.59	2.38	2.09	1.94
MPA	75		3.45	3.21	2.84	2.68	2.54	2.19	2.04

